

DAYBREAK VILLAGE 4A PLAT 9 SUBDIVISION AMENDING LOT T4 OF THE KENNECOTT MASTER SUBDIVISION #1

SURVEYOR'S CERTIFICATE

I, Marshall D. Byrd do hereby certify that I am a Registered Land Surveyor, and that I hold certificate No. 6390728 as prescribed under the laws of the State of Utah. I further certify that by the authority of the owners, I have made a survey of the tract of land shown on this plat and described below and have subdivided said tract of land into lots and streets, hereafter to be known as DAYBREAK VILLAGE 4A PLAT 9 SUBDIVISION and the same has been correctly surveyed and staked on the ground as shown on this plat.

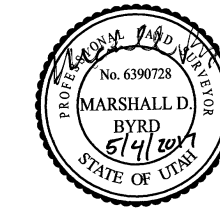

5/4/2017
Date

Marshall D. Byrd
Marshall D. Byrd
Professional Land Surveyor
Utah Certificate No. 6390728

Located in the Northeast quarter of Section 24,
T35, R2W, Salt Lake Base and Meridian

Containing 32 Lots 2,894 acres
Containing 1 P-Lot 18,149 S.F. - 0.417 acres
Containing 3 M-Lots 160,675 S.F. - 3.684 acres
Containing 3 Public Lanes 0.422 acres
Street Right-of-Way 0.678 acres
(Street Right-of-Way includes 0.190 acres of park strips which shall be counted as open space towards the calculation of the open space requirement set forth in the Master Development Agreement.)
Total boundary acreage 8.100 acres

DEVELOPED BY:

Daybreak Communities
4700 Daybreak Parkway
South Jordan, Utah 84009

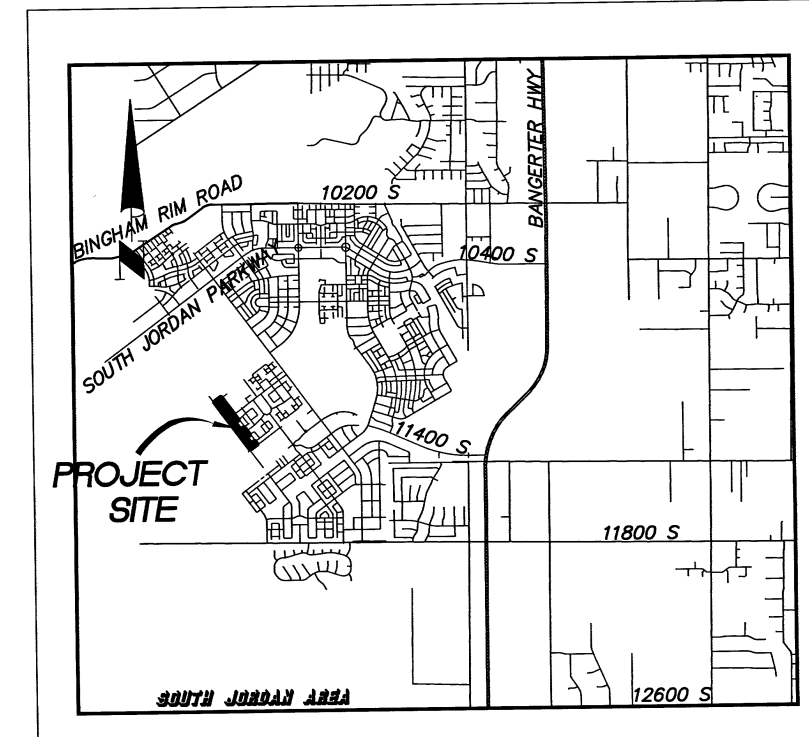

VICINITY MAP OWNER'S DEDICATION

Know all men by these presents that the undersigned owner of the above described tract of land, having caused the same to be subdivided into lots and streets to be hereafter known as:

DAYBREAK VILLAGE 4A PLAT 9 SUBDIVISION AMENDING LOT T4 OF THE KENNECOTT MASTER SUBDIVISION #1

do hereby dedicate for perpetual use of the public all parcels of land and easements as shown on this plat as intended for public use.

In witness whereof I have here unto set my hand this
6th day of MARCH, A.D., 2017.

VP Daybreak Operations LLC,
a Delaware limited liability company
By: Daybreak Communities LLC,
a Delaware limited liability company
Its: Project Manager

Ty K. McCutcheon
Ty K. McCutcheon
President & CEO

CORPORATE ACKNOWLEDGMENT

"The Owner's Dedication was acknowledged before me this 6th day of March, 2017, by Ty K. McCutcheon as President & CEO for Daybreak Communities LLC, a Delaware limited liability company, the project manager of VP Daybreak Operations LLC, a Delaware limited liability company."

Annette A. Mabey
Annette A. Mabey
Notary Public

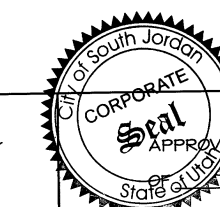
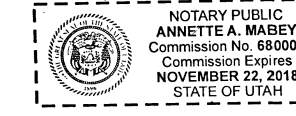

SOUTH JORDAN CITY MAYOR
APPROVED AS TO FORM THIS 30 DAY
OF JUNE, A.D., 2017
Anna M. West
Anna M. West
MAYOR

OFFICE OF THE CITY ATTORNEY
APPROVED AS TO FORM THIS 30 DAY
OF JUNE, A.D., 2017
Raoul
Raoul
ATTORNEY FOR SOUTH JORDAN CITY

NOTES:

- In conjunction with the recordation of this plat for DAYBREAK VILLAGE 4A PLAT 9 SUBDIVISION, there shall also be recorded, with respect to the "tract" described herein, a document entitled "Supplement to Covenant for Community for Daybreak Submitting Additional Property", and, with respect to the residential lots and certain other lots within this Plat, a document entitled "Supplement to Community Charter for Daybreak Submitting Additional Property" (each, a "Supplement"). The Supplements subject the "tract" described herein to a document entitled "Covenant for Community for Daybreak" (the "Covenant"), and the residential lots and certain other lots within this Plat to a second document entitled "Community Charter for Daybreak" (the "Charter"). In addition, any non-residential lot(s) may also have recorded against them a "Supplement to Amended and Restated Declaration of Covenants, Conditions and Restrictions for Daybreak Village Submitting Additional Property", which subjects such non-residential lots within this Plat to the "Amended and Restated Declaration of Covenants, Conditions and Restrictions for Daybreak Village" (the "Village Declaration"). This Plat is part of a master-planned community commonly known as "Daybreak" and is subject to the Master Development Agreement recorded on March 26, 2003 as Entry No. 898957, in Book 8762 beginning on Page 7103 of the Official Records of Salt Lake County (which Master Development Agreement may be amended from time to time) (the "Master Development Agreement").
- The "tract" subdivided by this Plat is hereby specifically subjected to a reservation by the Owner of (i) all oil, gas, geothermal and mineral rights and interests under or appurtenant to the "tract" subdivided by this Plat, and (ii) all water flowing or located under, within, over, or through the "tract" subdivided by this Plat, including, without limitation, all storm water and reclaimed water. The "tract" subdivided by this Plat is further subject to all easements, restrictions, reservations, rights-of-way, shortages in area, encroachments, or other encumbrances, whether such matters are of record or otherwise enforceable at law or in equity.
- All areas identified on this Plat as public rights-of-way are intended for public use and are hereby dedicated for the perpetual use of the public pursuant to the Owner's dedication shown hereon. All other areas are not dedicated for public use by this Plat. Lots designated as "O" and "P" are to be dedicated or donated to either: (i) the city or other governmental entity, or (ii) an owners' association for common area use, in a subsequently recorded instrument or an amendment to this Plat. Any easement shown on this Plat that is not specifically referred to as "public" is reserved to Owner or to Owner's designee.
- The Owner reserves, in favor of Daybreak Water Company, a Utah non-profit corporation, easements over, across and under all streets, public rights-of-way, alleys, "P" lots and "O" lots, and other public use areas, and all public utility and drainage easement areas to install, maintain, repair, and otherwise operate and accomplish all things associated with, a secondary water system providing secondary water to portions of Daybreak.
- On any lot in this Plat encumbered by a blanket PUDE easement, Owner reserves the right to relocate and/or more particularly define the location of such easement by Owner recording a notice of such location concerning such lot in the Official Records of Salt Lake County. Owner's relocation or definition of the easement is subject to existing utility's consent.
- From and after recordation of this plat, any amendment thereto or further subdivision thereof or within thereunto shall not be deemed to be an amendment to the Kennecott Master Subdivision #1 referred to hereon. Further subdivision of the Kennecott Master Subdivision #1 is consented to by any owner at any time hereafter purchasing or having an interest in any lots shown on this plat.
- Certain lots on this Plat may be served by sewer laterals that are less than 11 feet below ground level. In such event the residences on such lots with basements may not have sewer service available to the basements. The owner of any lot in this Plat shall be responsible for verifying the sewer lateral depth serving said lot and shall be responsible for setting the foundation elevation of the residence constructed thereon to a depth sufficient for adequate fall into the respective sewer lateral.

EASEMENT NOTE:

Owner certifies that the easements, claims of easements, or encumbrances on the platted property which are shown by public records as shown on this plat, based on the title report issued by First American Title Co., Order Number 0511-630305, Amendment No. 06 with an effective date of 07/23/14, 2017.

HIGH GROUND WATER:

Many areas in South Jordan City have ground water problems due to high (fluctuating) water table. Approval of this plat does not constitute representation by the City that building at any specified elevation will solve groundwater problems, if any.

SEWER LATERAL NOTE:

All lots contained within this Plat are served by private sewer laterals. The owner(s) of a lot in this Plat or any portion of an Alpha Parcel which is served by a sewer lateral which traverses a lot labeled "P" or "O", a public right-of-way, or a PUDE easement is hereby granted an easement over any through such "P" and/or "O" lots, public rights-of-way and/or PUDE easements for the purpose of allowing such owner(s) the right to operate, maintain and repair such sewer lateral. Promptly following any construction, repairs or maintenance requiring disturbance of the surface or subsurface of a burdened property, the benefited party shall cause the surface and subsurface of the burdened property to be restored to a condition substantially similar to the condition prior to such disturbance.

SEWER NOTE:

The signature of South Valley Sewer District on this plat does not constitute any guarantee of availability of sanitary sewer service to the property or any approval of sewer lines or facilities. The owner(s) of the property must provide satisfactory plans to the Sewer District for review and approval before connecting to the District's sewer system and will be required to comply with the District's rules and regulations.

NOTICE:

Potential purchasers of property described on this plat are advised by South Jordan City to familiarize themselves with all notes, lot information, easements and other pertinent information contained on this plat and also with any Covenants, Conditions and Restrictions ("CCRs") recorded against such property, including those described in note 1 of this plat. Such property may also be subject to the restrictions of the Kennecott Development Standards Matrix ("Matrix") attached to the Kennecott Master Subdivision #1 Plat recorded in Book 2002P commencing at Page 273, in the Salt Lake County Recorder's Office, as it may be amended from time to time. Financial losses to the property owner, purchasers and property owners are responsible to review and to be in compliance with this plat, the CCRs, the Matrix and other recorded documents related to this plat, as currently existing or as may from time to time be changed and/or amended.



EASEMENT APPROVAL
CENTURY LINK: *Box* DATE: 3-7-17
PACIFICORP: *Box* DATE: 3-7-17
QUESTAR GAS: *Box* DATE: 3-7-17
CONCAST: *Box* DATE: 3-7-17

SALT LAKE VALLEY HEALTH DEPARTMENT
APPROVED AS TO FORM THIS 27th DAY
OF June, A.D., 2017
Jeremy Roberts
Jeremy Roberts
SALT LAKE VALLEY HEALTH DEPARTMENT

SOUTH VALLEY SEWER DISTRICT
APPROVED AS TO FORM THIS 19 DAY
OF June, A.D., 2017
[Signature]
GENERAL MANAGER

PLANNING DEPARTMENT
APPROVED AS TO FORM THIS 27th DAY
OF June, A.D., 2017, BY THE
SOUTH JORDAN PLANNING DEPARTMENT.
[Signature]
CITY PLANNER

SOUTH JORDAN CITY ENGINEER
I HEREBY CERTIFY THAT THIS OFFICE HAS
EXAMINED THIS PLAT AND IT IS CORRECT
IN ACCORDANCE WITH INFORMATION ON
FILE IN THIS OFFICE.
6/21/17 *Brad Klavans*
DATE SOUTH JORDAN CITY ENGINEER

OFFICE OF THE CITY ATTORNEY
APPROVED AS TO FORM THIS 30 DAY
OF JUNE, A.D., 2017
[Signature]
ATTORNEY FOR SOUTH JORDAN CITY

SOUTH JORDAN CITY RECORDER
APPROVED AS TO FORM THIS 7th DAY
OF MARCH, A.D., 2017
[Signature]
CITY RECORDER

SOUTH JORDAN CITY MAYOR
APPROVED AS TO FORM THIS 30 DAY
OF JUNE, A.D., 2017
[Signature]
MAYOR

STATE OF UTAH, COUNTY OF SALT LAKE, RECORDED AND FILED AT THE
REQUEST OF: First American Title
DATE: 7-7-2017 TIME: 12:54 PM BOOK: 2017D PAGE: 177
FEE \$ 3186.00
SALT LAKE COUNTY RECORDER
2017P-177

A09-1
Sheet 1 of 5

06-24-21 06-24-200-022, -023

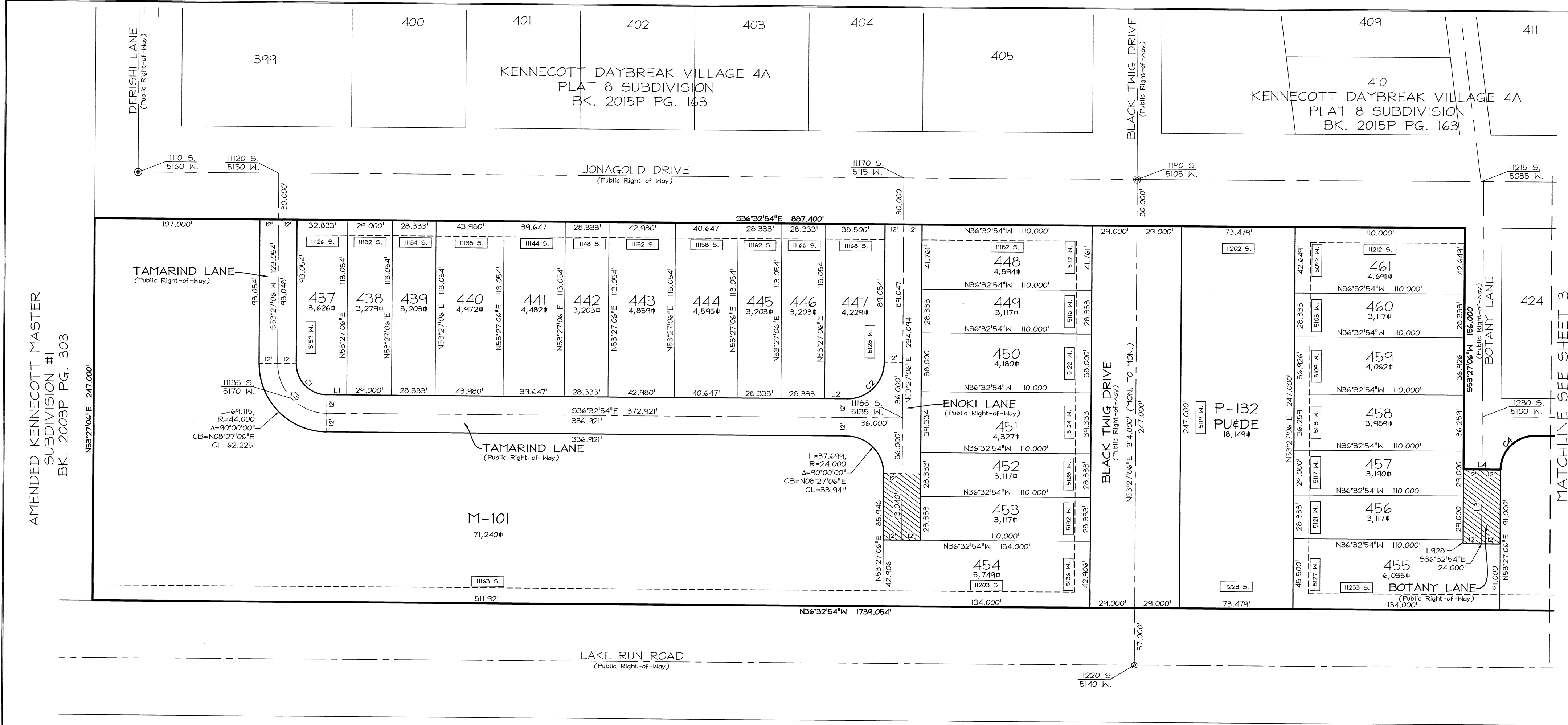

AMENDED KENNECOTT MASTER
SUBDIVISION #1
BK. 2003P PG. 303

AMENDED KENNECOTT MASTER
SUBDIVISION #1
BK. 2003P PG. 303

Line #	Length	Direction
L1	12.833	S36°32'54"E
L2	14.500	S36°32'54"E
L3	48.095	S53°27'06"W
L4	24.000	S36°32'54"E

Curve #	Length	Radius	Delta	Chord Bearing	Chord Length
C1	31.416	20.000	090°00'00"	S08°27'06"W	28.284
C2	37.699	24.000	090°00'00"	S81°32'54"E	33.941
C3	50.265	32.000	090°00'00"	S08°27'06"W	45.255
C4	34.558	22.000	090°00'00"	S81°32'54"E	31.113
C5	42.914	46.000	053°27'06"	S63°16'27"E	41.374

LEGEND

- FOUND SALT LAKE COUNTY SECTION CORNER
- PROPOSED STREET MONUMENT
- EXISTING STREET MONUMENT
- ADDRESS WITH ABBREVIATION OF STREET OR LANE
- 1' DRAINAGE EASEMENT PARALLEL TO LOT LINE (UNLESS NOTED OTHERWISE)
- PUBLIC RIGHT-OF-WAY: SOUTH JORDAN CITY WILL NOT PROVIDE SNOW REMOVAL, STREET SWEEPING OR GARBAGE COLLECTION IN THESE AREAS. SNOW REMOVAL AND STREET SWEEPING ARE THE RESPONSIBILITY OF THE ADJACENT LOT OWNERS. GARBAGE CANS MUST BE PLACED ON THE THROUGH PORTION OF THE ADJACENT LANE OR STREET.

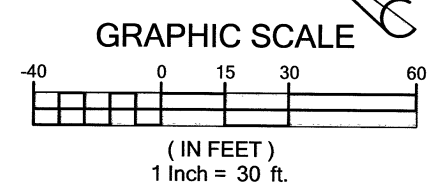
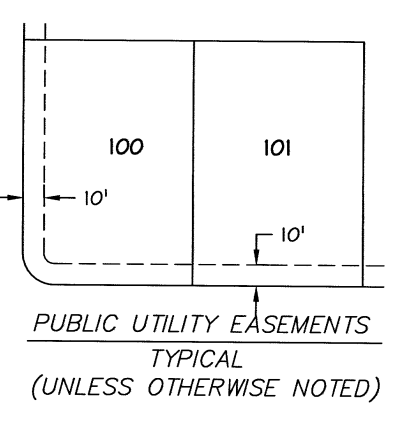

Sheet 2 of 5

PROPERTY CORNERS
PROPERTY CORNERS TO BE SET WILL BE REBAR # CAP OR NAILS SET IN THE TOP OF CURB OR ALLEY ON THE EXTENSION OF SIDE LOT LINES.

PERIGEE CONSULTING
CIVIL • STRUCTURAL • SURVEY

8089 SOUTH 1300 WEST, SUITE 160 WEST JORDAN, UT 84088
801.528.8004 TEL. 801.580.8011 FAX WWW.PERIGEECIVIL.COM

DAYBREAK VILLAGE 4A PLAT # SUBDIVISION AMENDING LOT T4 OF THE KENNECOTT MASTER SUBDIVISION #1 AMENDED

Located in the Northeast quarter of Section 24, T3S, R21W, Salt Lake Base and Meridian

RECORDED # 1267389
STATE OF UTAH, COUNTY OF SALT LAKE, RECORDED AND FILED AT THE REQUEST OF: First American Title
DATE: 7-7-2017 TIME: 12:54 PM BOOK: 2017P PAGE: 177
FEE \$ \$186.00
SALT LAKE COUNTY RECORDER

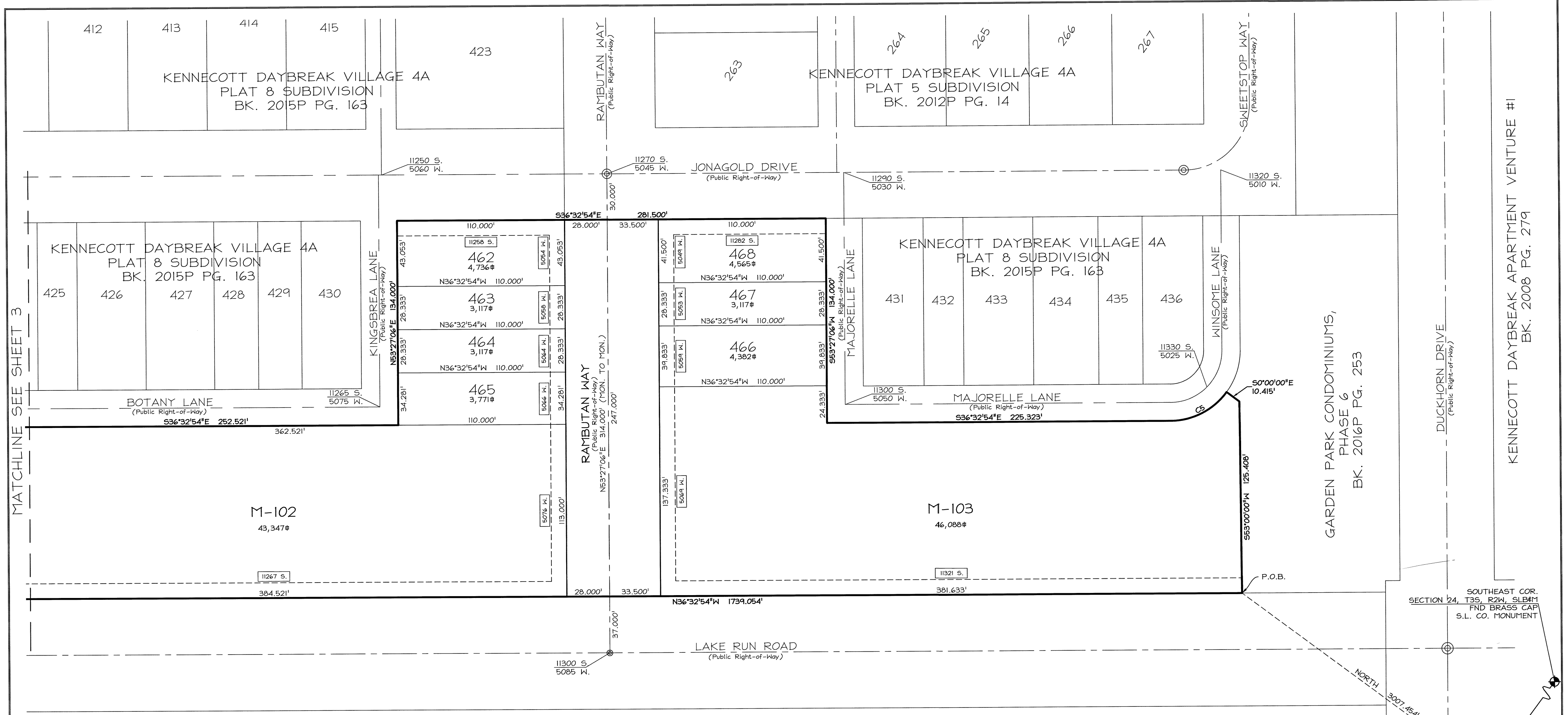

AMENDED KENNECOTT MASTER
SUBDIVISION #1
BK. 2003P PG. 303

PROPERTY CORNERS
PROPERTY CORNERS TO BE SET WILL BE REBAR & CAP OR NAILS SET IN THE TOP OF CURB OR ALLEY ON THE EXTENSION OF SIDE LOT LINES.

PERIGEE CONSULTING
CIVIL • STRUCTURAL • SURVEY

9089 SOUTH 1300 WEST, SUITE 160 WEST JORDAN, UT 84088
801.628.6004 TEL 801.590.6611 FAX WWW.PERIGEECIVIL.COM

LEGEND

- FOUND SALT LAKE COUNTY SECTION CORNER
- PROPOSED STREET MONUMENT
- EXISTING STREET MONUMENT
- ADDRESS WITH ABBREVIATION OF STREET OR LANE
- 1' DRAINAGE EASEMENT PARALLEL TO LOT LINE (UNLESS NOTED OTHERWISE)
- PUBLIC RIGHT-OF-WAY: SOUTH JORDAN CITY WILL NOT PROVIDE SNOW REMOVAL, STREET SWEEPING OR GARBAGE COLLECTION IN THESE AREAS. SNOW REMOVAL AND STREET SWEEPING ARE THE RESPONSIBILITY OF THE ADJACENT LOT OWNERS. GARBAGE CANS MUST BE PLACED ON THE THROUGH PORTION OF THE ADJACENT LANE OR STREET.

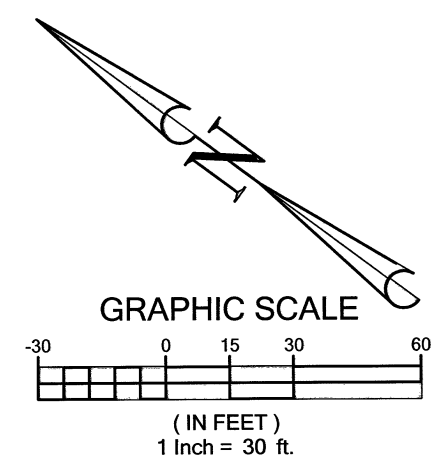

Sheet 3 of 5

SOUTH QUARTER COR. SECTION 24, T35, R2W, S164M
FND BRASS CAP
S.L. CO. MONUMENT

DAYBREAK VILLAGE 4A PLAT 9 SUBDIVISION
AMENDING LOT T4 OF THE KENNECOTT MASTER SUBDIVISION #1 AMENDED

Located in the Northeast quarter of Section 24, T35, R2W, Salt Lake Base and Meridian

RECORDED # 12571394
STATE OF UTAH, COUNTY OF SALT LAKE, RECORDED AND FILED AT THE REQUEST OF: First American Title
DATE: 7-2-2017 TIME: 12:54pm BOOK: 2017P PAGE: 177
\$186.00 FEE \$
SALT LAKE COUNTY RECORDER

AMENDED KENNECOTT MASTER
SUBDIVISION #1
BK. 2003P PG. 303

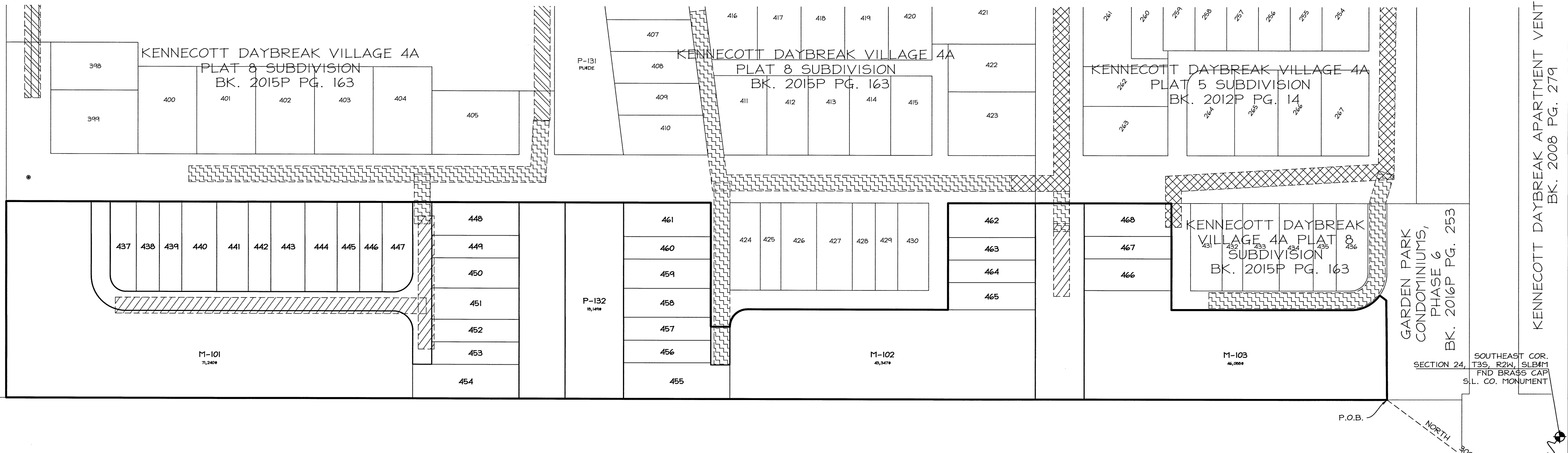

AMENDED KENNECOTT MASTER
SUBDIVISION #1
BK. 2003P PG. 303

PROPERTY CORNERS

PROPERTY CORNERS TO BE SET WILL BE REBAR 4 CAP OR NAILS SET IN THE TOP OF CURB OR ALLEY ON THE EXTENSION OF SIDE LOT LINES.

PERIGEE CONSULTING
CIVIL • STRUCTURAL • SURVEY

9089 SOUTH 1300 WEST, SUITE 160 WEST JORDAN, UT 84088
801.628.6004 TEL. 801.560.8611 FAX WWW.PERIGEECIVIL.COM

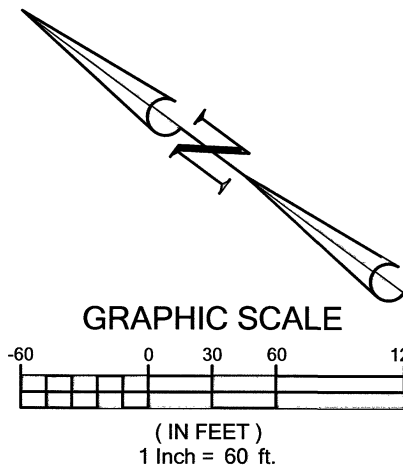

LEGEND

- EXISTING 20' WIDE SEWER EASEMENT RECORDED IN BOOK 10920 PAGE 1757
- EXISTING 20' WIDE SEWER EASEMENT RECORDED IN BOOK 9955 PAGE 1449
- EXISTING 20' WIDE SEWER EASEMENT RECORDED IN BOOK 10417 PAGE 0601
- EXISTING 20' WIDE SEWER EASEMENT RECORDED IN BOOK 10266 PAGE 5850

Sheet 4 of 5

DAYBREAK VILLAGE 4A PLAT 9 SUBDIVISION
AMENDING LOT T4 OF THE KENNECOTT MASTER
SUBDIVISION #1 AMENDED

Located in the Northeast quarter of Section 24,
T3S, R2W, Salt Lake Base and Meridian

RECORDED # 1257184
STATE OF UTAH, COUNTY OF SALT LAKE, RECORDED AND FILED AT THE
REQUEST OF: *First American Title*
DATE: *2-2-2017* TIME: *12:54 PM* BOOK: *2017P* PAGE: *177*
FEE: *\$786.00*
R. DePuy
SALT LAKE COUNTY RECORDER

PLAT NUMBER	DAYBREAK PARK LOT AREA	DAYBREAK OPEN SPACE LOT AREA	COLLECTOR STREET PARK STRIP AREA	NON-COLLECTOR STREET PARK STRIP AREA	PARK AREA DEDICATED TO CITY	OPEN SPACE AREA DEDICATED TO CITY	TOTAL	NUMBER OF LANES	LINEAR FOOTAGE
PLAT 1	2.5723	22.23	2.28	5.23	26.0377	0	58.35	13	4,887.83
PLAT 1 AMENDED	12.61	22.17	2.28	5.23	26.0377	0	68.33	13	4,887.83
LOT 104 AMENDED	0	0	0	0	0	0	0	0	0
PLAT 2	8.6753	1.0496	1.32	4.74	0	0	15.7849	21	6,340.29
PLAT 2 AMENDED	8.6093	1.0496	1.32	4.74	0	0	15.7189	21	6,340.29
TOWNHOME 1 SUB.	0	0	0	0	0	0	0	0	0
PLAT 3	2.6437	11.6106	0.32	5.89	0	0	20.4643	9	2,105.88
PLAT 4	0.7252	0.3496	0.24	1.97	0	0	3.2848	9	4,589.98
PLAT 4 AMENDED	0.7593	0.3363	0.24	1.97	0	0	3.3056	9	4,589.98
CARRIAGE CONDOS	0	0	0	0	0	0	0	0	0
PLAT 5	2.9994	2.7368	1.18	5.39	0	0	12.3062	36	10,719.18
PLAT 5 AMENDED	5.7505	0	1.18	5.39	0	0	12.3205	36	10,719.18
PLAT 6	3.371	31.8148	0	3.89	0	0	39.0758	13	3,532.29
PLAT 7	16.3272	7.6526	6.27	5.11	0	0	35.3598	5	1,690.56
PLAT 3A	1.736	0	0.1	0.39	0	0	2.226	5	1,690.56
PLATS 3B-1 THRU 3B-10	0	0	0	0	0	0	0	0	0
CORPORATE CENTER #1	0	0	0.07	0.1	0	0	0.17	13	4,227.78
PLAT 8	13.8622	0.0431	0.38	3.77	0	0	18.0553	13	4,227.78
PLAT 7A AMENDED	16.3272	7.6526	6.27	5.11	0	0	35.3598	5	1,690.56
EASTLAKE VILLAGE CONDOS	0	0	0	0	0	0	0	0	0
PLAT 9	17.8005	0	5.04	5.92	0	0	28.7605	38	11,087.08
PLAT 7B AMENDED	14.7624	7.6526	7.83	5.11	0	0	35.355	38	11,087.08
VILLAGE CENTER 1A	0	0	0	0	0	0	0	0	0
AMENDED EASTLAKE VILLAGE CONDOS	0	0	0	0	0	0	0	0	0
PLAT 9A AMENDED	17.8005	0	5.04	5.92	0	0	28.7605	38	11,087.08
AMENDED PLAT 1A	12.61	22.17	2.28	5.23	26.0377	0	68.3277	13	4,887.83
DAYBREAK VIEW PARKWAY SUBDIVISION FROM PLAT A1 TO THE EAST FRONTAGE ROAD	0	0	1.36	0	0	0	1.36	0	0
APARTMENT VENTURE #1	0	0	1.3	1.14	0	0	2.44	0	0
PLAT 3C	0	0	0.84	0	0	0	0.84	0	0
DAYBREAK VIEW PARKWAY SUBDIVISION FROM EAST FRONTAGE ROAD TO 11800 SOUTH	0	0	1.11	0.04	0	0	1.15	0	0
COMMERCE PARK PLAT 1	0	0	0.19	0.22	0	0	0.41	0	0
COMMERCE PARK PLAT 2	0	0	0.47	0	0	0	0.47	0	0
PLAT 8A-1	0	0	0	0	0	0	0	2	749
PLAT 8A-2	0	0	0	0	0	0	0	0	0
VILLAGE 4A PLAT 1	2.149	0	1.49	0	0	0	3.639	7	1,028.00
VILLAGE 4A PLAT 2	0.8623	0	0.61	0	0	0	1.4723	7	1,028.00
PLAT 8A-3	0	0	0	0	0	0	0	0	0
PLAT 8A-4	0	0	0	0	0	0	0	0	0
PLATS 8A-5 THRU 8A-9	0	0	0	0	0	0	0	0	0
PLAT 7C AMENDED	14.7624	7.3647	7.83	5.11	0	0	35.0671	35	10,037.21
AMENDED VILLAGE 4A PLAT 2	0.8623	0	0.61	0	0	0	1.4723	3	709.76
EASTLAKE ELEMENTARY SCHOOL	0	0	0	0	0	0	0	0	0
COUPLER LINER PRODUCT #1	0	0	0	0	0	0	0	0	0
PLAT 3D	0.0138	0	0.12	0	0	0	0.1338	2	449.14
AMENDED PLAT 3B-10	0	0	0	0	0	0	0	1	33.72
VCI DAYCARE	0	0	0.38	0.04	0	0	0.42	0	0
VCI CONDO SUBDIVISION	0	0	0	0	0	0	0	0	0
VILLAGE 4A PLAT 3	2.9531	0	1.36	0.37	0	0	4.8831	3	1,283.96
BINGHAM CREEK PLAT	142.713	0	0	0	0	0	142.713	0	0
11400/MVC SE COMMERCIAL #1	0	0	0	0	0	0	0	0	0
QUESTAR/IVWCD PLAT	0	0	0	0	0	0	0	0	0
VILLAGE 4A MULTI FAMILY #1	1.05	0	0	0	0	0	1.05	0	0
UNIVERSITY MEDICAL #1	0	0	0.41	0	0	0	0.41	0	0
PLAT 10A	0.766	0	0.64	0	0	0	1.406	2	1,291.32
VCI MULTI FAMILY #1	0.0903	0	0	0	0	0	0.0903	0	0
AMENDED PLAT 10A	0.766	0	0.64	0	0	0	1.406	2	1,291.32
GARDEN PARK CONDOMINIUMS, PHASE 1	0	0	0	0	0	0	0	0	0
GARDEN PARK CONDOMINIUMS, PHASE 3	0	0	0	0	0	0	0	0	0
PLAT 9B	0	0	0	0	0	0	0	0	0
PLAT 9C	-0.2014	0	0	0	0	0	-0.2014	0	0
PLAT 3E	0.0251	0	0.36	0	0	0	0.3851	1	389
AMENDED UNIVERSITY MEDICAL #1	0	0	0.26	0.22	0	0	0.48	0	0
SOUTH JORDAN PARKWAY ROW PLAT FROM SPLIT ROCK DRIVE TO 5360 WEST	0	0	1.21	0	0	0	1.21	0	0
PLAT 9C	0.0998	0	0	0	0	0	0.0998	0	0
AMENDED VCI MULTI FAMILY #1	0.0903	0	0	0	0	0	0.0903	3	412.58
VCI MULTI FAMILY #2A	0.11	0	0	0	0	0	0.111	1	502.5
PLAT 9D	0	0	0	0	0	0	0	2	484
AMENDED PLAT 3E	0	0	0	0	0	0	0	0	0
PLAT 7D	0	0	0	0	0	0	0	0	0
VCI MULTI FAMILY #2B	0.3087	0	0	0	0	0	0.3087	1	194.33
VILLAGE 4A PLAT 4	0.8077	0	0.26	0.23	0	0	1.2977	2	718.52
VILLAGE 4A PLAT 5	1.5901	0	0.68	0.00	0	0	2.2701	4	1,125.22
PLAT 10B	0	0	0.2	0.09	0	0	0.29	0	0
PLAT 7E	0	0	0	0	0	0	0	0	0
PLAT 9F	0	0	0	0	0	0	0	0	0
PLAT 7F	0	0	0	0	0	0	0	0	0
VCI MULTI FAMILY #3	0.1297	0	0	0	0	0	0.1297	0	0
VILLAGE 4A MULTI FAMILY #2	0	0	0	0	0	0	0	0	0
PLAT 9G	-0.2921	0	0	0	0	0	-0.2921	6	1,303.42
PLAT 10C	1.0818	0	0.14	0.65	0	0	1.8718	4	1,097.20
PLAT 8D	0	0	0	0	0	0	0	0	0
PLAT 8B	0	0	0	0	0	0	0	0	0
PLAT 9H	0	0	0	0	0	0	0	0	0
VILLAGE 4 WEST PLAT 1	0.2552	0	2.02	0.48	0	0	2.7552	2,000	1,088
VCI MULTI FAMILY #4	0	0	0	0	0	0	0	0	0
VILLAGE 4 EAST PLAT 1	1.4911	0	0	0.86	0	0	2.3511	6	1,524.61
VCI MULTI FAMILY #4A	0.3296	0	0	0	0	0	0.3296	0	0
PLAT 10D	0.3384	0	0.18	0.35	0	0	0.8684	6	924.04
VCI MULTI FAMILY #5	0.2651	0	0	0	0	0	0.2651	0	0
VILLAGE 4A PLAT 6	1.002	0	0.99	0.31	0	0	2.302	10	1,837.74
PLAT 10E	0.9735	0	1.31	0.51	0	0	2.7955	8	2,892.33
PLAT 9I	0	0	0	0	0	0	0	0	0
OQUIRREH LAKE PLAT	0	105.945	0	0	0	0	105.945	0	0
VILLAGE 4 WEST PLAT 2	0.293	0	0	0.27	0	0	0.563	2	891.76

PLAT NUMBER	DAYBREAK PARK LOT AREA	DAYBREAK OPEN SPACE LOT AREA	COLLECTOR STREET PARK STRIP AREA	NON-COLLECTOR STREET PARK STRIP AREA	PARK AREA DEDICATED TO CITY	OPEN SPACE AREA DEDICATED TO CITY	TOTAL	NUMBER OF LANES	LINEAR FOOTAGE
VILLAGE 5 PLAT 1	0	0	0.58	0	0	0	0.58	0	0
PLAT 10F	6.7848	0	0	0	0	0	6.7848	0	0
VCI MULTI FAMILY #6	0.091	0	0	0	0	0	0.091	1	508.05
VILLAGE 5 PLAT 2	0.3984	0	0.13	0.72	0	0	1.2484	7	2,583.35
VILLAGE 5 PLAT 3	1.2195	0	0.22	1.11	0	0	2.5495	16	3,781.25
PLAT 10G	0	0	0.33	0.29	0	0	0.62	4	1,208.13
VILLAGE 4 EAST CONDOMINIUM NO. 1 AMENDED	0	0	0	0	0	0	0	0	0
VILLAGE 4 EAST CONDOMINIUM NO. 2 AMENDED	0	0	0	0	0	0	0	0	0
VILLAGE 4 EAST PLAT 2	0.1964	0	0	0.66	0	0	0.8564	6	1,524.61
VILLAGE 4 EAST PLAT 3	0.4098	0	0	0.21	0	0	0.6198	6	1,524.61
VILLAGE 4A PLAT 7	0	0	0.46	0.2	0	0	0.66	1	150
COMMERCE PARK PLAT 3	0	0	0	0	0	0	0	0	0
VILLAGE 4A PLAT 4	3.5868	0	0.1	0.96	0	0	4.6468	19	3,532.59
VILLAGE 4A PLAT 8	0.3688	0	0.52	0.02	0	0	0.9088	6	1,687.31
VILLAGE 4 WEST PLAT 1 AMENDED	0.1275	0	0	0	0	0	0.1275	0	0
VCI MULTI FAMILY #1	0.0903	0	0	0.02	0	0	0.1103	4	1,161.21
VCI MULTI FAMILY #7	0.1485	0	0	0.04	0	0	0.1885	0	0
SOUTH STATION MULTI FAMILY #1	0.4972	0	0	0	0	0	0.4972	0	0
VILLAGE 7A PLAT 1	0	0	0.12	0	0	0	0.12	0	0
S. JORDAN PKWY. ROW DED. PLAT FROM 5360 WEST TO MT. VIEW CORR.	0	0	2.6	0	0	0	2.6	0	0
PLAT 10H	1.6574	0	1.17	0.99	0	0	3.8174	10	2,672.92
VILLAGE 5 PLAT 5	0.0644	0	0.91	0.44	0	0	1.4144	4	1,125.38
PLAT 10I	2.067	0	0.36	1.15	0	0	3.577	10	3,294.81
VILLAGE 10 NORTH PLAT 1	0	0	0.15	0.04	0	0	0.19	0	0
VILLAGE 5 PLAT 6	0.5937	0	0.11	0	0	0	0.7037	2	752.23
VILLAGE 5 PLAT 7	0	0	0	0.34	0	0	0.34	2	672
UNIVERSITY MEDICAL #2	0	0	0.06	0	0	0	0.06	0	0
VILLAGE 10 NORTH PLAT 2	0	0	0	0	0	0	0	0	0
VILLAGE 7	6.0122	0	2.09	0	0	0	8.1022	0	0
LAKE AVENUE FROM MOUNTAIN VIEW CORRIDOR TO 6000 WEST	15.1509	0	1.32	0	0	0	16.4709	0	0
VILLAGE 7 PLAT 1	1.1435	0	0	0.74	0	0	1.8835	7	2,183.79
VILLAGE 8									