

SURVEYOR'S CERTIFICATE:

I, James G. West, do hereby certify that I am a Registered Land Surveyor, and that I hold Certificate No. 3082, as prescribed under the laws of the State of Utah. I further certify that by authority of the Owners, I have made a survey of the tract of land shown on this plat and described below, and have subdivided said tract of land into lots and streets, hereafter to be known as

"THE VILLAGE AT KIMBALL JUNCTION"

and that the same has been correctly surveyed and staked on the ground as shown on this plat.

Date 12/2/91 James G. West
James G. West, R. L. S. #3082

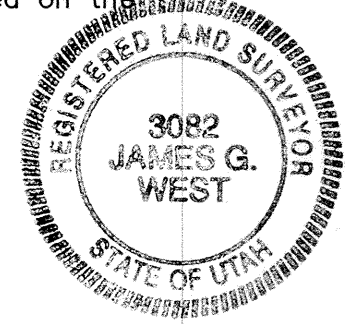

BOUNDARY DESCRIPTION:

Beginning at the Northwest Corner of Section 19, Township 1 South, Range 4 East, Salt Lake Base and Meridian, Summit County, Utah, running thence along the north section line of said section 19, SOUTH 89° 46' 57" East 2667.41 feet to the North Quarter Corner of said Section 19; thence South 00° 16' 14" East 752.13 feet along the east line of the Northwest Quarter of said Section 19 to the true point of beginning, said point being on the south right-of-way line of Frontage Road also known as U.D.O.T. project F-060(2), running thence along said east line South 00° 16' 14" East 3239.42 feet to the East Corner of the Southwest Quarter of said Section 19; thence South 89° 46' 27" West along the north line of the South Half of the Southeast Quarter of the Southwest Quarter of said Section 19, a distance of 1306.14 feet to a point on the east right-of-way line Utah State Highway 224; thence North 00° 27' 00" East along said right-of-way line 2668.37 feet; thence North 04° 57' 15" East 250.47 feet along said right-of-way line; thence North 07° 04' 10" West 151.37 feet along said right-of-way line to a point on the South right-of-way line of said Frontage Road; thence South 89° 17' 51" East 503.39 feet along said south right-of-way line to the beginning of 555.87 foot radius curve to the left (Delta = 22° 16' 41", radius bears North 00° 42' 09" East); thence along the arc of said curve and said right-of-way line 216.14 feet to a point of tangency; thence North 68° 25' 28" East along said right-of-way a distance of 397.20 feet to the beginning of a 251.48 foot radius curve to the right (Delta = 39° 29' 32", radius bears South 21° 34' 32" East); thence along the arc of said curve and said right-of-way line a distance of 173.34 feet; thence South 34° 19' 06" East along said right-of-way a distance of 23.15 feet to the Point of Beginning.

Contains 4,028,965.90 sqft. or 92.492 acres.

OWNER'S DEDICATION AND CONSENT TO RECORD

Know all men by these presents: That the undersigned are the owners of the herein described tract of land, and hereby cause: the same to be divided into lots and streets together with easements as set forth on the attached plat, and covenants referenced hereto, hereafter to be known as "THE VILLAGE AT KIMBALL JUNCTION". Also the owners hereby dedicate to Summit County, Snyderville Basin Sewer Improvement District, Park City Fire Service District and Summit Water Distribution Company, a non-exclusive easement, over the roadways for providing emergency services and over the utility easements shown on this plat for the purpose of providing access for utility installation, maintenance, use and eventually replacement.

Executed this 6th day of December, 1991

John W. Jarman Helen B. Jarman
John W. and Helen B. Jarman
Bailey and Sons, Co., John W. Jarman, President

ACKNOWLEDGEMENT

State of Utah } CC.
County of Summit }

On the 6th day of December, 1991 personally appeared before me who, being by me duly sworn, did say that he is the President of Bailey and Sons, Co. and that the within and foregoing Owner's Dedication and Consent to Record was signed on behalf of said Bailey and Sons, Co. and said John W. Jarman duly acknowledged to me that said Bailey and Sons, Co. executed the same. AND JOHN W. AND HELEN B. JARMAN, INDIVIDUALLY, EXECUTED THE SAME.
Cheryl L. Thomson My commission expires 9/21/95

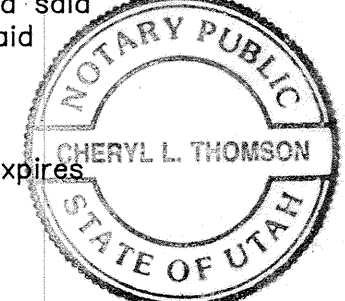

The Village at Kimball Junction

A Utah Subdivision Located in
A Portion of the West Half of Section 19,
Township 1 South, Range 4 East, Salt Lake
Base & Meridian, Summit County, Utah.

NOTE:
ALL DISTANCES ARE MEASURED.
NO MONUMENTS HAVE BEEN SET
AS OF 12-06-91.

PARK CITY FIRE SERVICE DISTRICT APPROVAL
APPROVAL AND ACCEPTED THIS 13th DAY OF JANUARY A. D. 1992
Gene Bonner
FIRE MARSHAL

UTAH POWER AND LIGHT COMPANY APPROVAL
APPROVED AND ACCEPTED THIS 6th DAY OF DECEMBER A. D. 1991
R Duane Ruffa

SNYDERVILLE BASIN SEWER IMPROVEMENT DIST. APPROVAL
APPROVED AND ACCEPTED THIS 29th DAY OF JANUARY A. D. 1992
Ray E. St.
S.B.S.I.D. GENERAL MANAGER ENGINEERING CORP.

SUMMIT COUNTY PUBLIC WORKS SUPERVISOR APPROVAL
APPROVED AND ACCEPTED THIS 9th DAY OF DECEMBER A. D. 1991
David Harper

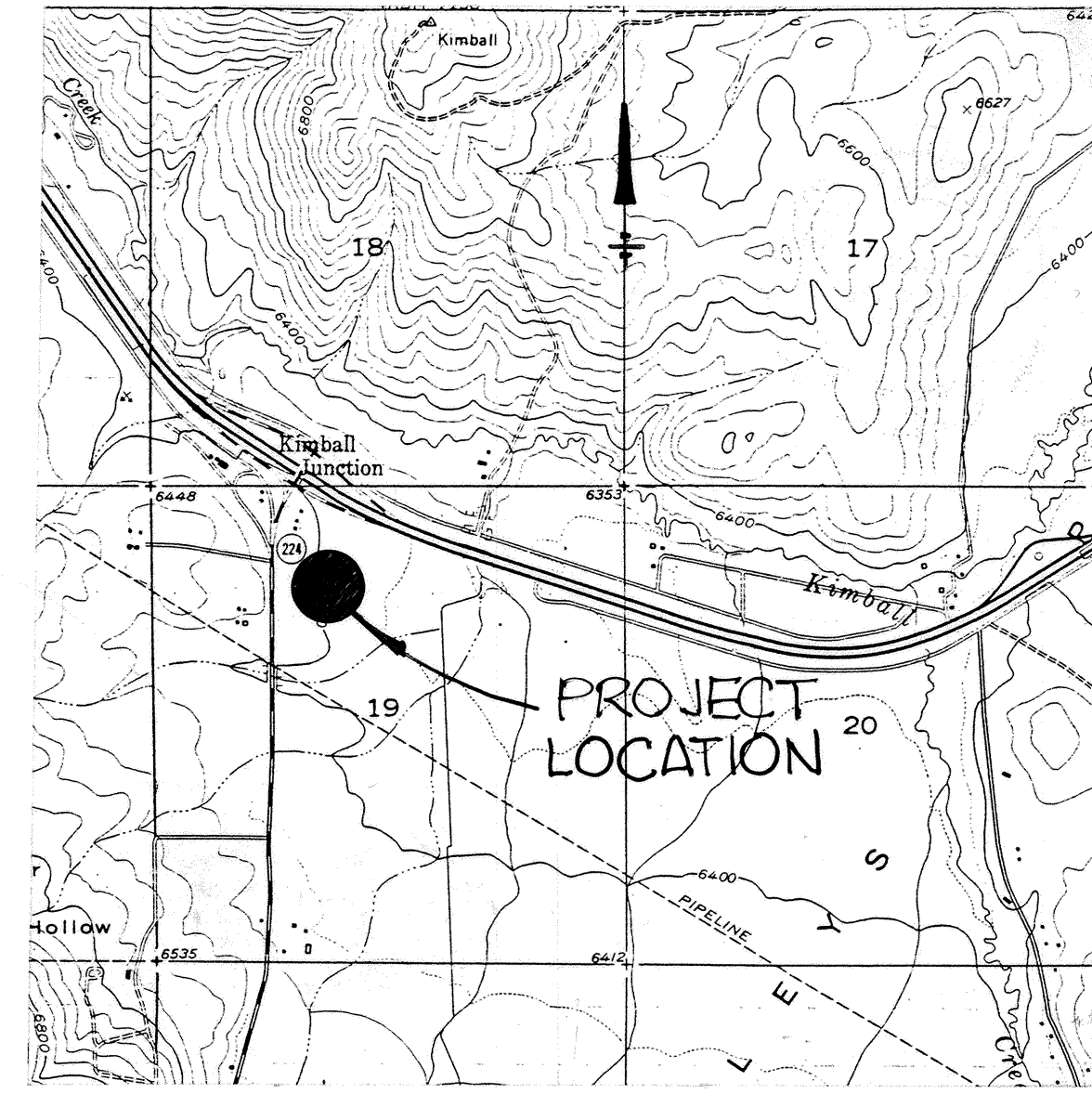
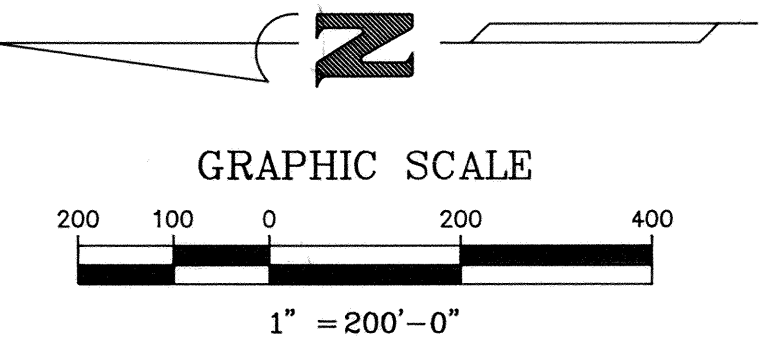

COUNTY COMMISSION APPROVAL
PRESENTED TO BOARD OF THE SUMMIT COUNTY COMMISSIONERS THIS 10th DAY OF March A. D. 1992.
AT WHICH TIME THIS SUBDIVISION WAS APPROVED AND ACCEPTED.
Shelley R. Riche
COUNTY COMMISSION CHAIRMAN
Wm. R. Ruffa
COUNTY CLERK

COUNTY ENGINEER
I, Richard M. Nell, SUMMIT COUNTY ENGINEER HEREBY CERTIFY THAT THIS PLAT HAS BEEN EXAMINED BY THIS OFFICE AND IT IS CORRECT IN ACCORDANCE WITH INFORMATION ON FILE IN THIS OFFICE.
1-22-92
DATE
Richard M. Nell
COUNTY ENGINEER

COUNTY PLANNING COMMISSION
APPROVED AND ACCEPTED BY THE SUMMIT COUNTY PLANNING COMMISSION ON THIS 11th DAY OF February A. D. 1992.
Robert M. Campbell
CHAIRMAN

APPROVAL AS TO FORM
APPROVED AS TO FORM ON THIS 11th DAY OF MARCH A. D. 1992.
Franklin P. Anderson
COUNTY ATTORNEY

RECORDED
No. 355411
STATE OF Utah
RECORDED AND FILED AT THE REQUEST OF Sessions Management Company
DATE: 3-11-92
TIME: 2:05 PM
FEES \$45.50
James G. West
COUNTY RECORDER

THE SEAR-BROWN GROUP
FULL SERVICE DESIGN PROFESSIONALS
1351 Deer Valley Rd. South, Suite 202 Park City, Utah 84060
(801) 649-9811 FAX (801) 649-7065

INTERSTATE 80

SPRING CREEK ANGUS RANCH PARTNERS

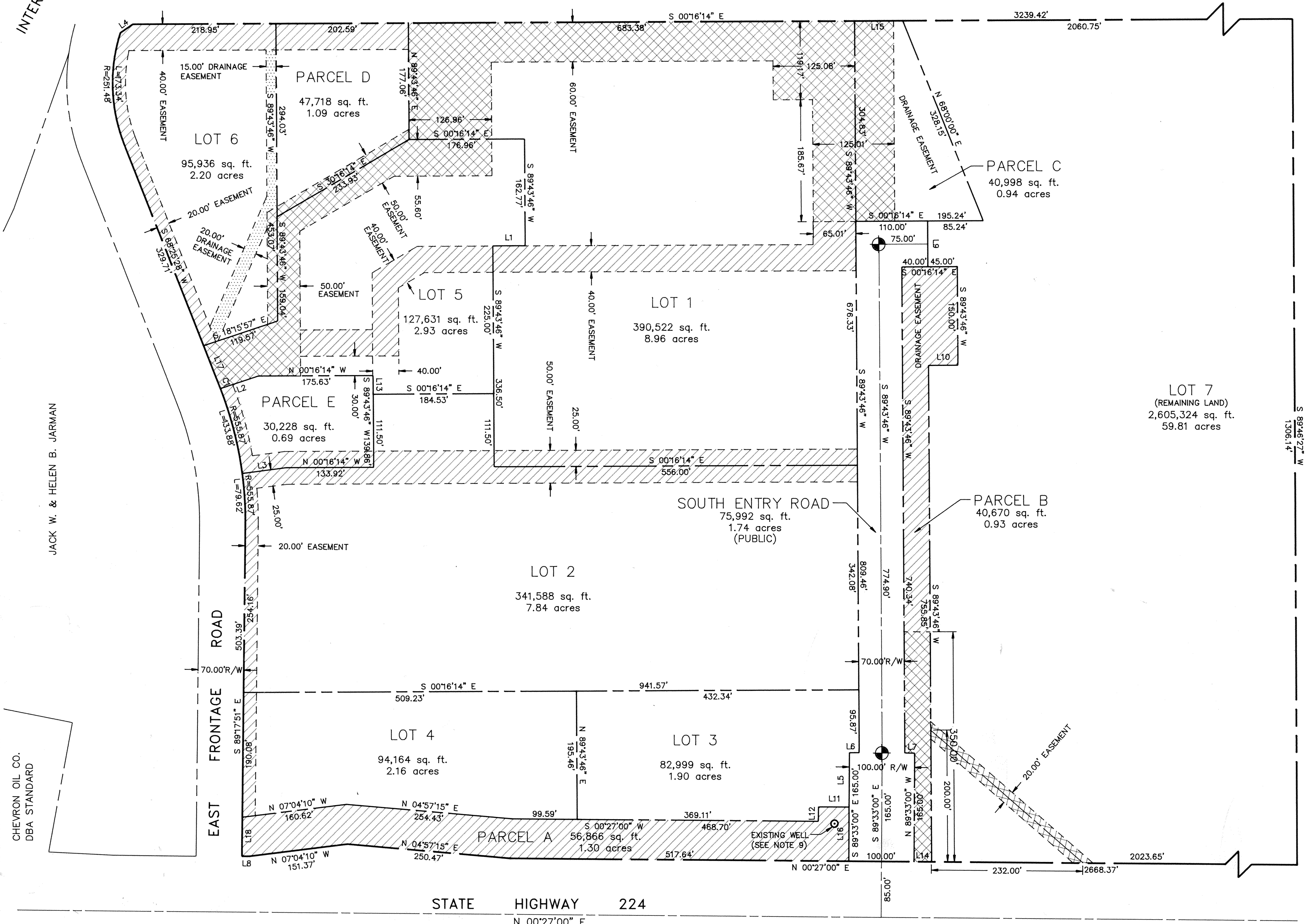

NOTES:

- Common area maintenance shall be governed as set forth in the Declaration of Covenants and Restrictions referenced hereto.
- South Entry Road to be Dedicated to Summit County.
- Street monuments to be set in accordance with Summit County specifications.
- All angle points, right-of-way and lot/parcel corners along property perimeter shall be monumented with 5/8" X 24" rebar, to include identifying RLS caps.
- Occupancy restriction: It is unlawful to occupy a building within this subdivision without first having obtained a Certificate of Occupancy from the Summit County Building Inspector.
- On July 25, 1991, a Class II permit was issued for development of Lots 1, 2 and 5. In accordance with this approval, building permits for Lots 1, 2 and 5 can be issued subsequent to County Agency review and approval of construction drawings.
Lots 3, 4, 6 and 7 will require individual Class II Permits from the Summit County Planning Commission prior to issuance of building permits for future uses thereon.
- Parcels B and C are also drainage easements for the benefit of Summit County.
- Parcels A & B are also a non-exclusive public utility easements.
- Existing wells shall be afforded a 100 foot protection zone from concentrated sources of pollution as set forth in the Utah Administrative Code, 1991, Volume 2, Section R449-106-2.
- Lots 2, 3, 4, 5, 6, and 7 will require individual sanitary sewer Line Extension Agreements from Snyderville Basin Sewer Improvement District prior to issuance of building permits for future uses thereon.
- Reference note 4. above:
All property corners shall be staked before obtaining signatures or approval of County Engineer.

LOT TABULATION

LOT No.	USE	AREA	FRONTAGE
LOT 1	KMART	8.96 acres	371'
LOT 2	OTHER ANCHOR	7.84 acres	342'
LOT 3	FUTURE	1.90 acres	179'
LOT 4	FUTURE	2.16 acres	190'
LOT 5	FUTURE	2.93 acres	67'
LOT 6	FUTURE	2.20 acres	503'
LOT 7	FUTURE	59.81 acres	2,023'
PARCEL A	COMMON AREA	1.31 acres	-
PARCEL B	COMMON AREA	0.93 acres	-
PARCEL C	COMMON AREA	0.94 acres	-
PARCEL D	COMMON AREA	1.09 acres	-
PARCEL E	COMMON AREA	0.69 acres	-
S. ENTRY RD.	RIGHT-OF-WAY**	1.74 acres	-
TOTAL AREA		92.49 acres	

**PUBLIC

TABLES

CURVE TABLE

CURVE	RADIUS	LENGTH	DELTA
C1	555.87'	2.63'	00°16'16"

LINE TABLE

LINE	DIRECTION	DISTANCE
L1	N 00°16'14" W	49.58'
L2	S 18°15'57" E	61.05'
L3	S 07°30'00" E	67.70'
L4	S 34°19'06" E	23.15'
L5	N 89°33'00" W	82.81'
L6	S 00°27'00" W	15.00'
L7	S 00°27'00" W	15.00'
L8	N 00°07'59" E	11.39'
L9	S 89°43'46" W	70.00'
L10	S 00°16'14" E	45.00'
L11	N 00°27'00" E	46.95'
L12	S 89°33'00" E	22.10'
L13	N 89°43'46" E	26.36'
L14	N 00°27'00" E	27.08'
L15	S 00°16'14" E	73.75'
L16	N 89°33'00" W	82.09'
L17	S 89°25'28" W	67.48'
L18	N 89°17'51" W	59.15'

LEGEND

- Survey Monument to be set.
- Non-Exclusive Public Utility Easement.
- Non-Exclusive Public Utility Easement and Sanitary Sewer Easement.

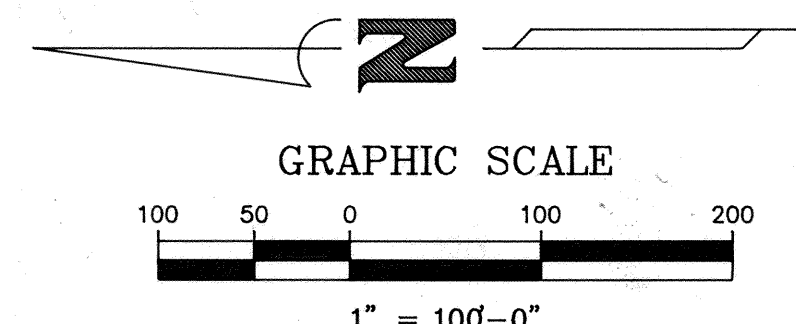

The Village at Kimball Junction

A Utah Subdivision Located in
A Portion of the West Half of Section 19,
Township 1 South, Range 4 East, Salt Lake
Base & Meridian, Summit County, Utah.

James G. West 12/2/91

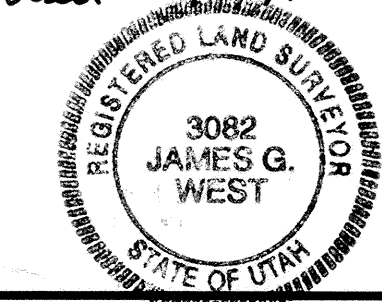

Sheet 2 of 2

RECORDED

No. 355411
STATE OF Utah
RECORDED AND FILED AT THE REQUEST OF
Sessions Management Company
Date: 3-11-92
Time: 2:05 PM
3:43:50
COUNTY RECORDER

THE SEAR-BROWN GROUP
FULL SERVICE DESIGN PROFESSIONALS
1351 Deer Valley Rd. South, Suite 202 Park City, Utah 84060
(801) 649-9811 FAX (801) 649-7065