

DRH EAGLE POINT TOWNHOMES PLAT "C"

A RESIDENTIAL SUBDIVISION

LOCATED IN THE NORTHEAST QUARTER OF SECTION 13, TOWNSHIP 6 SOUTH, RANGE 2

WEST, SALT LAKE BASE AND MERIDIAN
EAGLE MOUNTAIN CITY, UTAH COUNTY, UTAH

SHEET 1 OF 3

VICINITY MAP



SURVEYOR'S CERTIFICATE

I, KAGAN M. DIXON, DO HEREBY CERTIFY THAT I AM A PROFESSIONAL LAND SURVEYOR, AND THAT I HOLD LICENSE NO. 9061091 AS PRESCRIBED UNDER THE LAWS OF THE STATE OF UTAH. I FURTHER CERTIFY THAT BY THE AUTHORITY OF THE OWNERS, I HAVE MADE A SURVEY OF THE TRACT OF LAND SHOWN ON THIS PLAT AND DESCRIBED BELOW, AND HAVE SUBDIVIDED SAID TRACT OF LAND INTO LOTS, STREETS, AND EASEMENTS TO BE KNOWN AS EAGLE POINT TOWNHOMES PLAT "C", AND THE SAME HAS BEEN CORRECTLY SURVEYED AND STAKED ON THE GROUND AS SHOWN ON THIS PLAT AND THAT THIS PLAT IS TRUE AND CORRECT.

BOUNDARY DESCRIPTION

A PARCEL OF LAND LOCATED IN THE NORTHEAST QUARTER OF SECTION 13, TOWNSHIP 6 SOUTH, RANGE 2 WEST, SALT LAKE BASE AND MERIDIAN, SAID PARCEL BEING MORE PARTICULARLY DESCRIBED AS FOLLOWS:

BEGINNING AT THE SOUTHEAST CORNER OF THE EAGLE POINT TOWNHOMES PLAT "A" SUBDIVISION BOUNDARY AS RECORDED AS ENTRY 76286-2013 IN THE UTAH COUNTY RECORDER'S OFFICE, SAID POINT BEING ALSO ON THE WESTERLY RIGHT-OF-WAY LINE OF COSMOS DRIVE AS SHOWN IN THE EAGLE POINT ROAD DEDICATION PLAT AS RECORDED AS ENTRY 69966-2015 IN THE UTAH COUNTY RECORDER'S OFFICE, SAID POINT BEING NORTH 89°31'09" WEST 748.84 FEET AND SOUTH 448.23 FEET FROM THE NORTHEAST CORNER OF SECTION 13, TOWNSHIP 6 SOUTH, RANGE 2 WEST, SALT LAKE BASE AND MERIDIAN, AND RUNNING ALONG SAID RIGHT-OF-WAY OF SAID COSMOS DRIVE THE FOLLOWING TWO (2) COURSES: 1) SOUTHEASTERLY 278.19 FEET ALONG THE ARC OF A 1517.68 FOOT RADIUS NON-TANGENT CURVE TO THE LEFT (CHORD BEARS SOUTH 02°49'52" EAST 277.80 FEET); 2) SOUTHWESTERLY 31.55 FEET ALONG THE ARC OF A 20.00 FOOT RADIUS TANGENT CURVE TO THE RIGHT (CHORD BEARS SOUTH 37°06'20" WEST 28.38 FEET); THENCE SOUTH 07°42'38" EAST 191.66 FEET; THENCE NORTH 82°02'57" WEST 1044.49 FEET; THENCE NORTH 09°21'25" EAST 513.70 FEET; THENCE SOUTH 82°02'57" EAST 316.86 FEET TO THE WESTERLY RIGHT-OF-WAY OF SKYLINE DRIVE, AND RUNNING ALONG SAID RIGHT-OF-WAY SOUTHWESTERLY 15.51 FEET ALONG THE ARC OF A 3739.09 FOOT RADIUS NON-TANGENT CURVE TO THE RIGHT (CHORD BEARS SOUTH 06°38'54" WEST 15.51 FEET); THENCE SOUTH 83°13'59" EAST 50.00 FEET; THENCE ALONG SAID SKYLINE DRIVE RIGHT-OF-WAY NORTHEASTERLY 7.74 FEET ALONG THE ARC OF A 3789.09 FOOT RADIUS NON-TANGENT CURVE TO THE LEFT (CHORD BEARS NORTH 06°42'31" EAST 7.74 FEET); THENCE SOUTH 81°11'22" EAST 126.86 FEET; THENCE SOUTHEASTERLY 98.97 FEET ALONG THE ARC OF A 100.00 FOOT RADIUS TANGENT CURVE TO THE RIGHT (CHORD BEARS SOUTH 52°50'08" EAST 94.98 FEET); THENCE SOUTHEASTERLY 38.02 FEET ALONG THE ARC OF A 40.00 FOOT RADIUS TANGENT CURVE TO THE LEFT (CHORD BEARS SOUTH 51°39'44" EAST 36.61 FEET); THENCE NORTHEASTERLY 80.21 FEET ALONG THE ARC OF A 120.00 FOOT RADIUS TANGENT CURVE TO THE LEFT (CHORD BEARS NORTH 82°01'40" EAST 78.73 FEET); THENCE SOUTH 24°29'37" EAST 12.88 FEET; THENCE NORTH 55°36'13" EAST 29.27 FEET; THENCE SOUTH 83°24'33" EAST 7.50 FEET; THENCE SOUTH 32°00'39" EAST 8.44 FEET; THENCE SOUTHEASTERLY 25.81 FEET ALONG THE ARC OF A 28.00 FOOT RADIUS TANGENT CURVE TO THE LEFT (CHORD BEARS SOUTH 58°55'08" EAST 24.91 FEET); THENCE SOUTH 85°19'38" EAST 193.35 FEET; THENCE NORTHEASTERLY 12.43 FEET ALONG THE ARC OF A 13.00 FOOT RADIUS TANGENT CURVE TO THE LEFT (CHORD BEARS NORTH 67°16'49" EAST 11.86 FEET); THENCE NORTH 39°53'14" EAST 5.44 FEET; THENCE SOUTH 83°24'33" EAST 2.54 FEET TO THE POINT OF BEGINNING.

CONTAINING 11.44 ACRES, MORE OR LESS.
*THENCE NORTH 07°57'02" EAST 10.00 FEET; THENCE NORTH 82°01'58" WEST 131.5 FEET

July 19, 2021
DATE

[Signature]
SURVEYOR
(SEE SEAL BELOW)

OWNERS' DEDICATION

WE, THE UNDERSIGNED OWNERS OF ALL THE REAL PROPERTY DEPICTED ON THIS PLAT AND DESCRIBED IN THE SURVEYOR'S CERTIFICATE ON THIS PLAT, HAVE CAUSED THE LAND DESCRIBED ON THIS PLAT TO BE DIVIDED INTO LOTS, STREETS, EASEMENTS, AND OTHER PUBLIC USES AS DESIGNATED ON THE PLAT AND NOW DO HEREBY DEDICATE UNDER THE PROVISIONS OF 10-99-807, UTAH CODE, WITHOUT CONDITION, RESTRICTION, OR RESERVATION TO EAGLE MOUNTAIN CITY, UTAH, ALL STREETS, WATER, SEWER, AND OTHER UTILITY EASEMENTS AND IMPROVEMENTS, OPEN SPACES SHOWN AS PUBLIC-OPEN SPACES, PARKS AND ALL OTHER PLACES OF PUBLIC USE AND ENJOYMENT TO EAGLE MOUNTAIN CITY TOGETHER WITH ALL IMPROVEMENTS REQUIRED BY THE DEVELOPMENT AGREEMENT BETWEEN THE UNDERSIGNED AND EAGLE MOUNTAIN CITY FOR THE BENEFIT OF THE CITY AND THE INHABITANTS THEREOF.

PURSUANT TO UTAH CODE 10-9A-604 (D), THE OWNER HEREBY CONVEYS THE COMMON AREAS, AS INDICATED HEREON, TO THE DRH EAGLE POINT TOWNHOME OWNER'S ASSOCIATION, WITH A REGISTERED ADDRESS OF 12351 SOUTH GATEWAY PARK PLACE D-100, DRAPER, UTAH 84042

By: MARK J. GREEN, Manager
PRINTED NAME OF OWNER AUTHORIZED SIGNATURE(S)
GRANOL EAGLE POINT, LLC. July 19, 2021

PRINTED NAME OF OWNER AUTHORIZED SIGNATURE(S)

LC ACKNOWLEDGEMENT

STATE OF UTAH }
COUNTY OF DAVIS } S.S.
ON THIS 19 DAY OF July, A.D. 2021, PERSONALLY APPEARED BEFORE ME Mark J. Green, THE SIGNER OF THE FOREGOING INSTRUMENT, WHO DULY ACKNOWLEDGED TO ME THAT S(HE) IS A [MEMBER WITH MANAGEMENT AUTHORITY] [MANAGER] OF Granol Eagle Point LLC, A UTAH LIMITED LIABILITY COMPANY, AND IS AUTHORIZED TO EXECUTE THE FOREGOING AGREEMENT IN ITS BEHALF AND THAT HE OR SHE EXECUTED IT IN SUCH CAPACITY.

WITNESS MY HAND OFFICIAL SEAL.

I CERTIFY UNDER PENALTY OF PERJURY UNDER THE LAWS OF THE STATE OF UTAH THAT THE FOREGOING PARAGRAPH IS TRUE AND CORRECT.

NOTARY PUBLIC FULL NAME: David Lewis II ENT 169675; 2021 Exp 8 17943
COMMISSION NUMBER: 713890 UTAH COUNTY RECORDER
MY COMMISSION EXPIRES: Aug 31, 2024 2021 Exp 01 3449 per fee \$26.00 BY SA
RECORDED FOR EAGLE MOUNTAIN CITY

A NOTARY PUBLIC COMMISSIONED IN UTAH
David Lewis II

ACCEPTANCE BY LEGISLATIVE BODY

THE CITY COUNCIL OF EAGLE MOUNTAIN CITY, COUNTY OF UTAH, APPROVES THIS SUBDIVISION AND HEREBY ACCEPTS THE DEDICATION OF ALL STREETS, EASEMENTS, AND OTHER PARCELS OF LAND INTENDED FOR PUBLIC PURPOSES FOR THE PERPETUAL USE OF THE PUBLIC THIS 16 DAY OF August 2021.

APPROVED BY MAYOR: [Signature]
APPROVED BY CITY ATTORNEY: [Signature]
APPROVED BY CITY ENGINEER: [Signature]
APPROVED BY CITY RECORDER: [Signature]
(SEE SEAL BELOW) (SEE SEAL BELOW)

DRH EAGLE POINT TOWNHOMES PLAT "C"

A RESIDENTIAL SUBDIVISION
LOCATED IN THE NORTHEAST QUARTER OF SECTION 13, TOWNSHIP 6 SOUTH,
RANGE 2 WEST, SALT LAKE BASE AND MERIDIAN

SHEET 1 OF 3

SURVEYOR'S SEAL 	NOTARY PUBLIC SEAL 	CITY ENGINEER SEAL 	CLERK-RECORDER SEAL
---------------------	------------------------	------------------------	-------------------------

DIRECT COMMUNICATIONS

DIRECT COMMUNICATIONS CEDAR VALLEY, LLC CERTIFIED THAT IT WILL PROVIDE TELECOMMUNICATIONS SERVICES TO THIS SUBDIVISION UTILIZING THE TRENCHES PROVIDED BY THE DEVELOPER AS PER THE DIRECT COMMUNICATIONS CEDAR VALLEY P.S.C. UTAH NO. 1 TARIFF.

By: Margie Wilford DATE: 7/20/2021

DOMINION ENERGY

QUESTAR GAS COMPANY DBA DOMINION ENERGY UTAH HEREBY APPROVES THIS PLAT SOLELY FOR PURPOSE OF CONFIRMING THAT THE PLAT CONTAINS PUBLIC UTILITY EASEMENTS, DOMINION ENERGY UTAH MAY REQUIRE ADDITIONAL EASEMENTS IN ORDER TO SERVE THIS DEVELOPMENT. THIS APPROVAL DOES NOT CONSTITUTE ABROGATION OR WAIVER OF ANY OTHER EXISTING RIGHTS, OBLIGATIONS OR LIABILITIES INCLUDING PRESCRIPTIVE RIGHTS AND OTHER RIGHTS, OBLIGATIONS OR LIABILITIES PROVIDED BY LAW OR EQUITY. THIS APPROVAL DOES NOT CONSTITUTE ACCEPTANCE, APPROVAL OR ACKNOWLEDGMENT OF ANY TERMS CONTAINED IN THE PLAT, INCLUDING THOSE SET FORTH IN THE OWNERS DEDICATION AND THE NOTES, AND DOES NOT CONSTITUTE A GUARANTEE OF PARTICULAR TERMS OF NATURAL GAS SERVICE. FOR FURTHER INFORMATION PLEASE CONTACT DOMINION ENERGY UTAH'S RIGHT-OF-WAY DEPARTMENT AT 1-800-366-8532.

QUESTAR GAS COMPANY DBA DOMINION ENERGY UTAH APPROVED THIS 20 DAY OF July 2021

By: Dwight E. Adridge
TITLE: 11c - Con

ROCKY MOUNTAIN POWER

- PURSUANT TO UTAH CODE ANN. § 54-3-27 THIS PLAT CONVEYS TO THE OWNER(S) OR OPERATORS OF UTILITY FACILITIES A PUBLIC UTILITY EASEMENT ALONG WITH ALL RIGHTS AND DUTIES DESCRIBED THEREIN.
- PURSUANT TO UTAH CODE ANN. § 17-27a-603(4)(ii) ROCKY MOUNTAIN POWER ACCEPTS DELIVERY OF THE PUE AS DESCRIBED IN THIS PLAT AND APPROVES THIS PLAT SOLELY FOR THE PURPOSE OF CONFIRMING THAT THE PLAT CONTAINS PUBLIC UTILITY EASEMENTS AND APPROXIMATES THE LOCATION OF THE PUBLIC UTILITY EASEMENT, BUT DOES NOT WARRANT THEIR PRECISE LOCATION. ROCKY MOUNTAIN POWER MAY REQUIRE OTHER EASEMENTS IN ORDER TO SERVE THIS DEVELOPMENT. THIS APPROVAL DOES NOT AFFECT ANY RIGHT THAT ROCKY MOUNTAIN POWER HAS UNDER
 - A RECORDED EASEMENT OR RIGHT OF WAY
 - THE LAW APPLICATION TO PRESCRIPTIVE RIGHTS
 - TITLE 54, CHAPTER 8a, DAMAGE TO UNDERGROUND UTILITY FACILITIES, OR
 - ANY OTHER PROVISION OF LAW

By: Bob Todd DATE: July 20, 2021

TABULATIONS

TOTAL AREA	11.44 ACRES
TOTAL ACREAGE IN LOTS	3.20 ACRES
TOTAL OPEN SPACE	3.59 ACRES
TOTAL IMPROVED OPEN SPACE	3.59 ACRES
PUBLIC ROW DEDICATION	1.60 ACRES
PRIVATE ROW	0.91 ACRES
DRIVEWAYS/PARKING	2.54 ACRES
TOTAL NUMBER OF LOTS	132
AVERAGE LOT FOOTPRINT SIZE	1,058 SQ FT
LARGEST LOT FOOTPRINT SIZE	1,128 SQ FT
SMALLEST LOT FOOTPRINT SIZE	864 SQ FT
OVERALL DENSITY	11.53 LOTS/ACRE

This map is provided solely for the purpose of assisting in locating the property and Cottonwood Title Insurance Agency, Inc. assumes no liability for variation, if any, with any actual survey.

WILDING ENGINEERING
14721 SOUTH HERITAGE CREST WAY
BLUFFDALE, UTAH 84065
801.553.8112
WWW.WILDINGENGINEERING.COM

Dec. 13-26-20 TU-038

DRH EAGLE POINT TOWNHOMES PLAT "C"

A RESIDENTIAL SUBDIVISION

LOCATED IN THE NORTHEAST QUARTER OF SECTION 13, TOWNSHIP 6 SOUTH, RANGE 2 WEST, SALT LAKE BASE AND MERIDIAN

EAGLE MOUNTAIN CITY, UTAH COUNTY, UTAH

SHEET 2 OF 3

This map is provided solely for the purpose of assisting in locating the property and Cottonwood Title Insurance Agency, Inc. assumes no liability for variation, if any, with any actual survey.

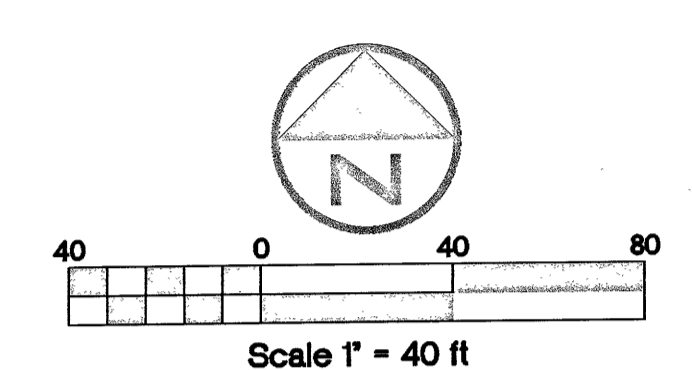
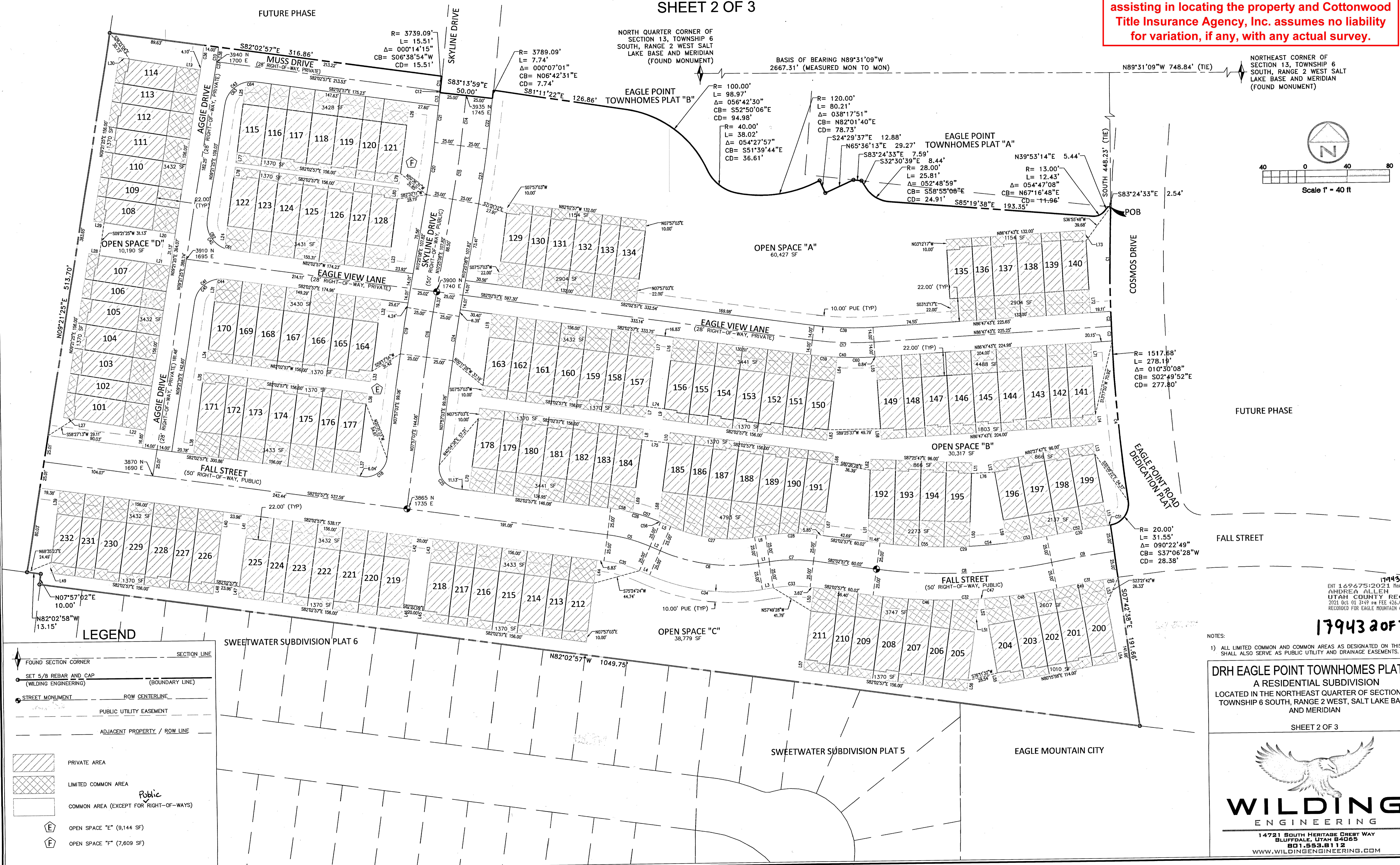

LEGEND

- FOUND SECTION CORNER
- SET 5/8 REBAR AND CAP (BOUNDARY LINE)
- STREET MONUMENT (ROW CENTERLINE)
- PUBLIC UTILITY EASEMENT
- ADJACENT PROPERTY / ROW LINE
- PRIVATE AREA
- LIMITED COMMON AREA
- COMMON AREA (EXCEPT FOR RIGHT-OF-WAYS)
- OPEN SPACE "E" (9,144 SF)
- OPEN SPACE "F" (7,609 SF)

17943
 ENT 169675:2022 Map # 17943
 ANDREA ALLEN
 UTAH COUNTY RECORD
 2021 Oct 01 3:49 PM FEE \$26.00 BY SA
 RECORDED FOR EAGLE MOUNTAIN CITY

17943 20F3

NOTES:
 1) ALL LIMITED COMMON AND COMMON AREAS AS DESIGNATED ON THIS PLAT SHALL ALSO SERVE AS PUBLIC UTILITY AND DRAINAGE EASEMENTS.

DRH EAGLE POINT TOWNHOMES PLAT "C"
 A RESIDENTIAL SUBDIVISION
 LOCATED IN THE NORTHEAST QUARTER OF SECTION 13,
 TOWNSHIP 6 SOUTH, RANGE 2 WEST, SALT LAKE BASE
 AND MERIDIAN

SHEET 2 OF 3

WILDING
 ENGINEERING

14721 SOUTH HERITAGE CREST WAY
 BLUFFDALE, UTAH 84065
 801.553.8112
 WWW.WILDINGENGINEERING.COM

DRH EAGLE POINT TOWNHOMES PLAT "C"

A RESIDENTIAL SUBDIVISION

LOCATED IN THE NORTHEAST QUARTER OF SECTION 13, TOWNSHIP 6 SOUTH, RANGE 2 WEST, SALT LAKE BASE AND MERIDIAN
EAGLE MOUNTAIN CITY, UTAH COUNTY, UTAH

SHEET 3 OF 3

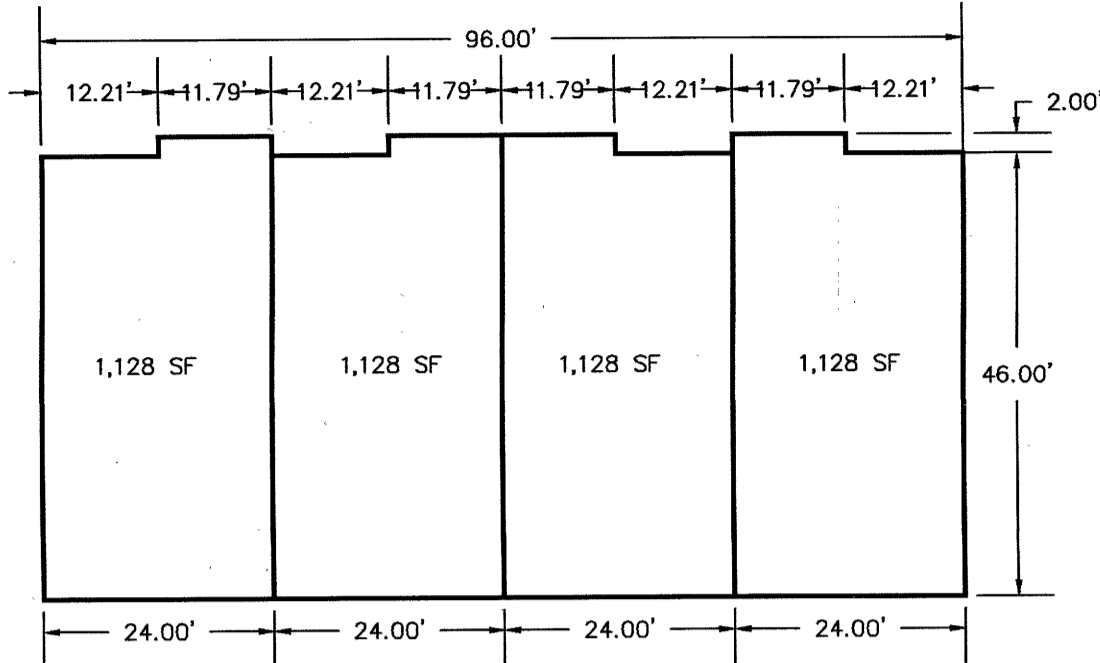

4-PLEX UNIT (TYP)

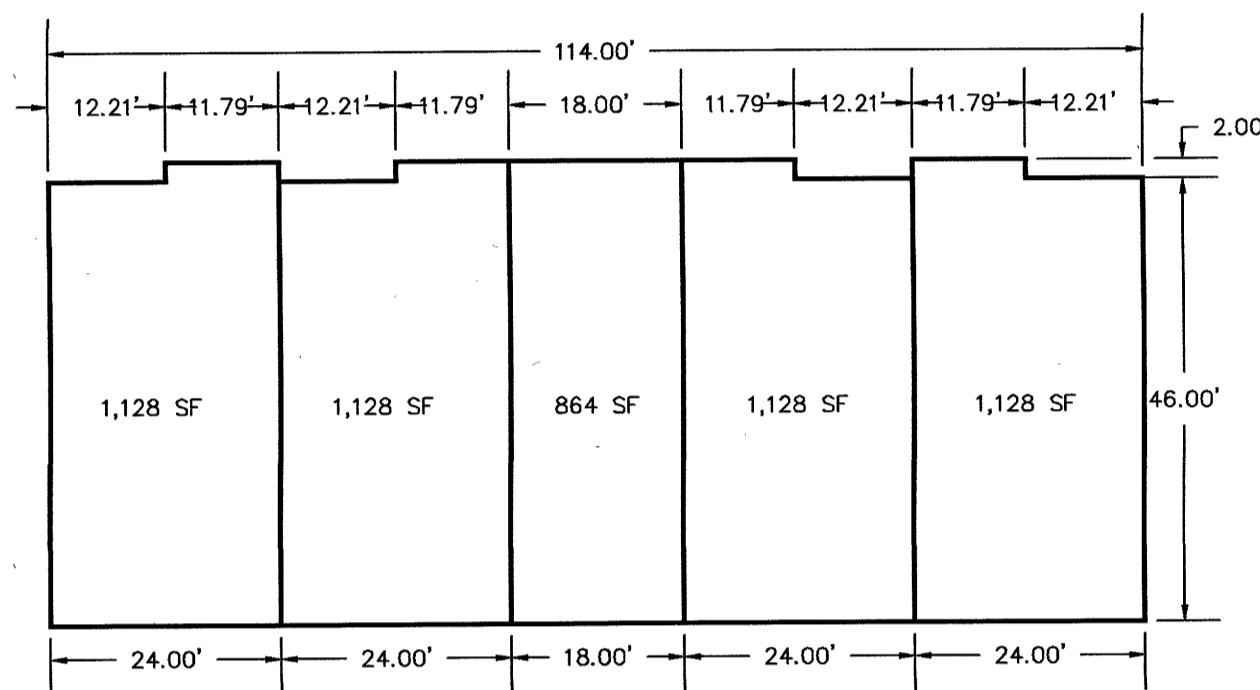

5-PLEX UNIT (TYP)

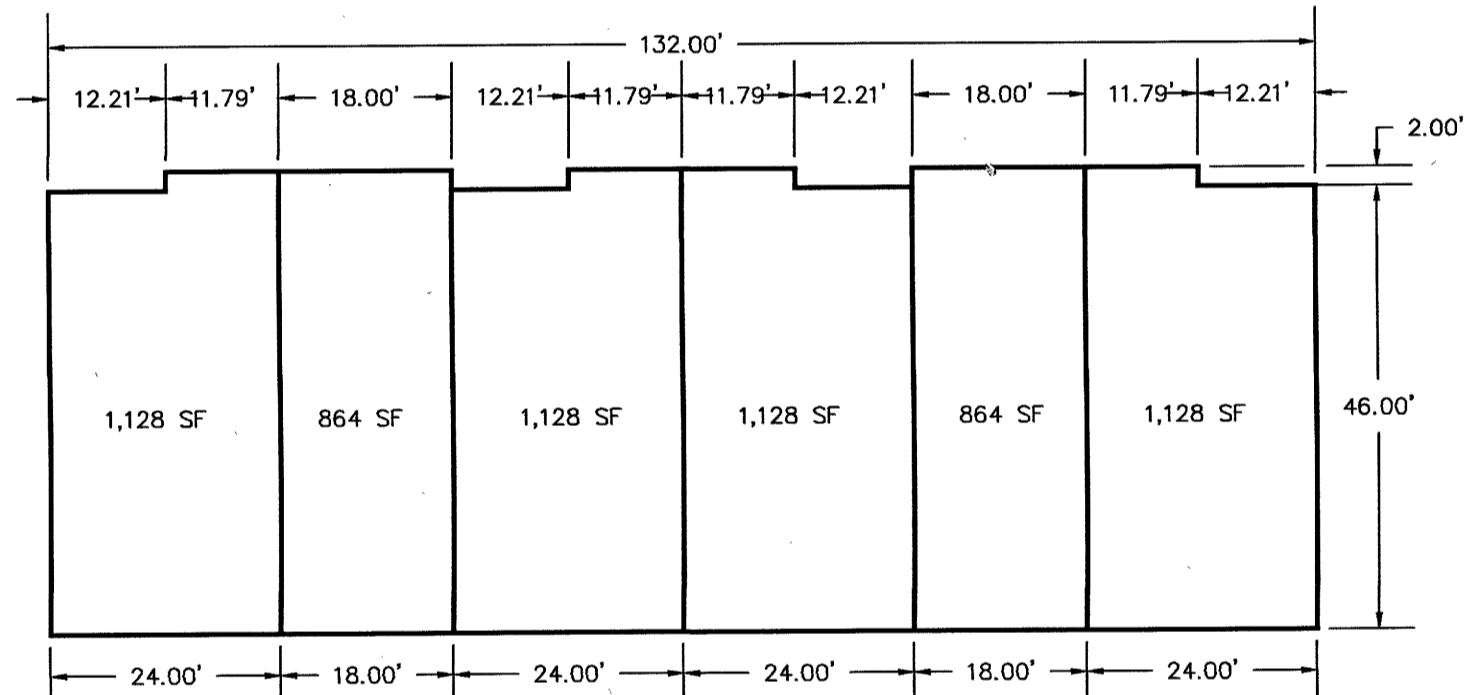

6-PLEX UNIT (TYP)

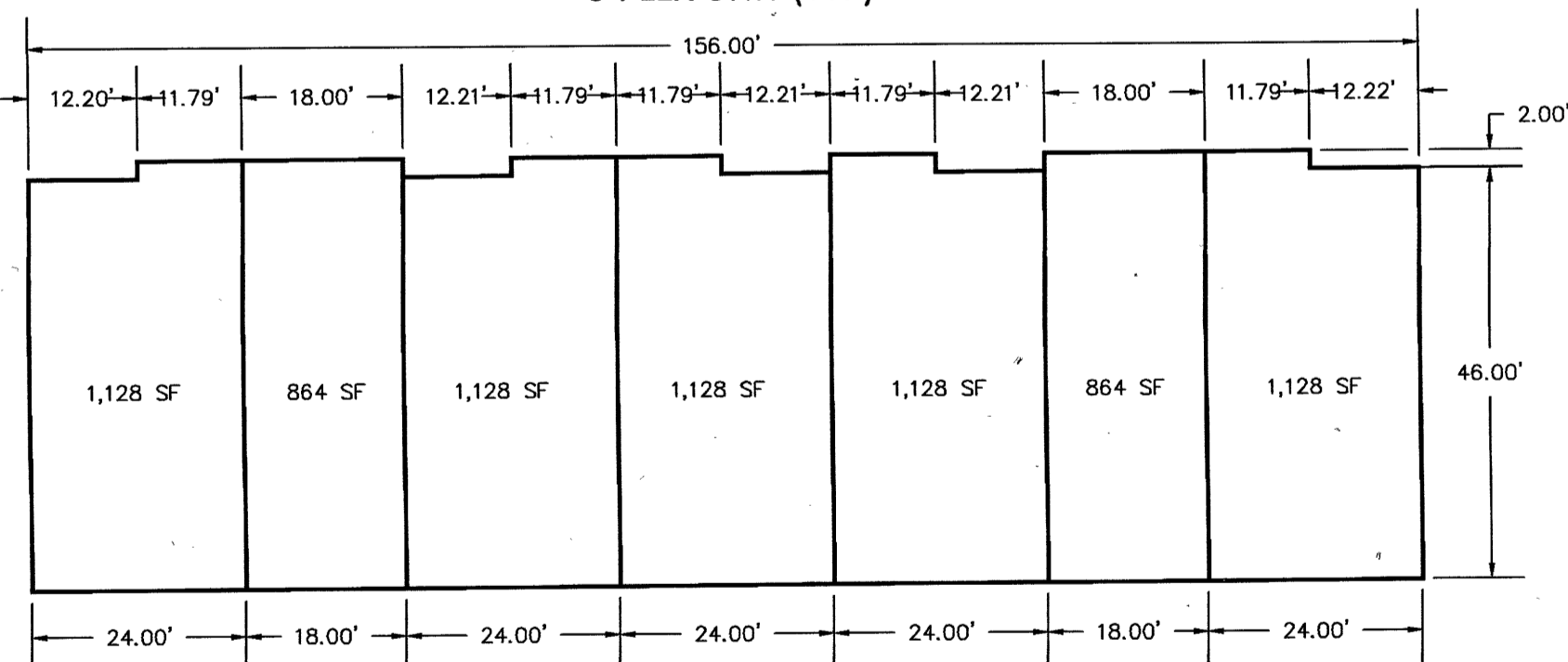

7-PLEX UNIT (TYP)

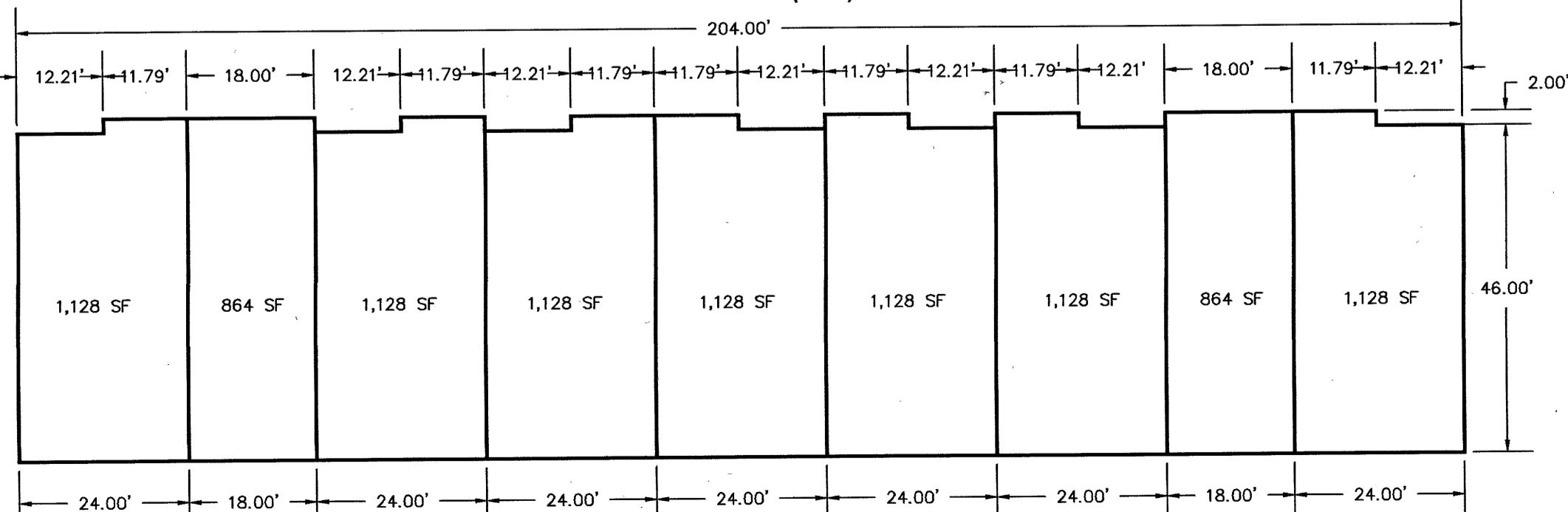

9-PLEX UNIT (TYP)

ADDRESS TABLES	ADDRESS TABLES		
UNIT #	ADDRESS	UNIT #	ADDRESS
101	3881 N AGGIE DRIVE	167	1716 E EAGLE VIEW LANE
102	3885 N AGGIE DRIVE	168	1712 E EAGLE VIEW LANE
103	3889 N AGGIE DRIVE	169	1708 E EAGLE VIEW LANE
104	3893 N AGGIE DRIVE	170	1704 E EAGLE VIEW LANE
105	3897 N AGGIE DRIVE	171	1703 E FALL STREET
106	3901 N AGGIE DRIVE	172	1707 E FALL STREET
107	3905 N AGGIE DRIVE	173	1711 E FALL STREET
108	3915 N AGGIE DRIVE	174	1715 E FALL STREET
109	3919 N AGGIE DRIVE	175	1719 E FALL STREET
110	3923 N AGGIE DRIVE	176	1723 E FALL STREET
111	3927 N AGGIE DRIVE	177	1727 E FALL STREET
112	3931 N AGGIE DRIVE	178	1749 E FALL STREET
113	3935 N AGGIE DRIVE	179	1753 E FALL STREET
114	3939 N AGGIE DRIVE	180	1757 E FALL STREET
115	1710 E MUSS DRIVE	181	1761 E FALL STREET
116	1714 E MUSS DRIVE	182	1765 E FALL STREET
117	1718 E MUSS DRIVE	183	1769 E FALL STREET
118	1722 E MUSS DRIVE	184	1773 E FALL STREET
119	1726 E MUSS DRIVE	185	1783 E FALL STREET
120	1730 E MUSS DRIVE	186	1787 E FALL STREET
121	1734 E MUSS DRIVE	187	1791 E FALL STREET
122	1709 E EAGLE VIEW LANE	188	1795 E FALL STREET
123	1713 E EAGLE VIEW LANE	189	1799 E FALL STREET
124	1717 E EAGLE VIEW LANE	190	1803 E FALL STREET
125	1721 E EAGLE VIEW LANE	191	1807 E FALL STREET
126	1725 E EAGLE VIEW LANE	192	1821 E FALL STREET
127	1729 E EAGLE VIEW LANE	193	1825 E FALL STREET
128	1733 E EAGLE VIEW LANE	194	1829 E FALL STREET
129	1765 E EAGLE VIEW LANE	195	1833 E FALL STREET
130	1769 E EAGLE VIEW LANE	196	1845 E FALL STREET
131	1783 E EAGLE VIEW LANE	197	1849 E FALL STREET
132	1767 E EAGLE VIEW LANE	198	1853 E FALL STREET
133	1771 E EAGLE VIEW LANE	199	1857 E FALL STREET
134	1775 E EAGLE VIEW LANE	200	1858 E FALL STREET
135	1835 E EAGLE VIEW LANE	201	1854 E FALL STREET
136	1839 E EAGLE VIEW LANE	202	1850 E FALL STREET
137	1843 E EAGLE VIEW LANE	203	1846 E FALL STREET
138	1847 E EAGLE VIEW LANE	204	1842 E FALL STREET
139	1851 E EAGLE VIEW LANE	205	1834 E FALL STREET
140	1855 E EAGLE VIEW LANE	206	1830 E FALL STREET
141	1859 E EAGLE VIEW LANE	207	1826 E FALL STREET
142	1862 E EAGLE VIEW LANE	208	1822 E FALL STREET
143	1845 E EAGLE VIEW LANE	209	1818 E FALL STREET
144	1844 E EAGLE VIEW LANE	210	1814 E FALL STREET
145	1840 E EAGLE VIEW LANE	211	1810 E FALL STREET
146	1836 E EAGLE VIEW LANE	212	1768 E FALL STREET
147	1832 E EAGLE VIEW LANE	213	1764 E FALL STREET
148	1828 E EAGLE VIEW LANE	214	1760 E FALL STREET
149	1824 E EAGLE VIEW LANE	215	1756 E FALL STREET
150	1810 E EAGLE VIEW LANE	216	1752 E FALL STREET
151	1806 E EAGLE VIEW LANE	217	1748 E FALL STREET
152	1802 E EAGLE VIEW LANE	218	1744 E FALL STREET
153	1798 E EAGLE VIEW LANE	219	1736 E FALL STREET
154	1794 E EAGLE VIEW LANE	220	1732 E FALL STREET
155	1790 E EAGLE VIEW LANE	221	1726 E FALL STREET
156	1786 E EAGLE VIEW LANE	222	1724 E FALL STREET
157	1778 E EAGLE VIEW LANE	223	1720 E FALL STREET
158	1774 E EAGLE VIEW LANE	224	1716 E FALL STREET
159	1770 E EAGLE VIEW LANE	225	1712 E FALL STREET
160	1766 E EAGLE VIEW LANE	226	1702 E FALL STREET
161	1762 E EAGLE VIEW LANE	227	1698 E FALL STREET
162	1758 E EAGLE VIEW LANE	228	1694 E FALL STREET
163	1754 E EAGLE VIEW LANE	229	1690 E FALL STREET
164	1728 E EAGLE VIEW LANE	230	1686 E FALL STREET
165	1724 E EAGLE VIEW LANE	231	1682 E FALL STREET
166	1720 E EAGLE VIEW LANE	232	1678 E FALL STREET

CURVE TABLE					
CURVE #	LENGTH	RADIUS	DELTA	CHORD BEARING	CHORD DISTANCE
C1	98.57'	1517.68'	3°43'16"	S00°33'34"W	98.55'
C2	14.01'	1517.68'	0°31'43"	S01°33'56"E	14.01'
C3	14.00'	1517.68'	0°31'43"	S02°05'39"E	14.00'
C4	151.61'	1517.68'	5°43'25"	S05°13'13"E	151.55'
C5	41.93'	150.00'	16°00'57"	N74°02'28"W	41.79'
C6	95.04'	170.00'	32°01'55"	S82°02'57"E	93.81'
C7	41.93'	150.00'	16°00'57"	S89°56'34"W	41.79'
C8	166.73'	500.00'	19°06'21"	N88°23'53"E	165.96'
C9	60.11'	1000.00'	3°26'39"	S80°34'02"W	60.10'
C10	19.92'	500.00'	2°16'56"	N08°12'57"E	19.91'
C11	14.00'	3739.09'	0°12'53"	N06°38'13"E	14.00'
C12	1.50'	3739.09'	0°01'23"	N06°45'20"E	1.50'
C13	12.50'	3270.16'	0°13'09"	N06°47'55"E	12.50'
C14	47.65'	3294.77'	0°49'43"	N07°06'14"E	47.65'
C15	51.08'	1000.00'	2°55'35"	N08°57'21"E	51.07'
C16	43.08'	1000.00'	2°28'05"	S09°11'06"W	43.07'
C17	58.41'	300.00'	11°09'20"	S87°37'37"E	58.32'
C18	31.42'	20.00'	90°00'00"	N52°57'03"E	28.28'
C19	44.15'	1025.00'	2°28'05"	S09°11'06"W	44.15'
C20	49.80'	975.00'	2°55'35"	N08°57'21"E	49.79'
C21	47.33'	3270.16'	0°49'45"	N07°06'14"E	47.33'
C22	47.97'	3319.39'	0°49'41"	N07°06'15"E	47.96'
C23	52.35'	1025.00'	2°55'35"	N08°57'21"E	52.35'
C24	42.00'	975.00'	2°28'05"	S09°11'06"W	42.00'
C25	31.42'	20.00'	90°00'00"	S37°02'57"E	28.28'
C26	48.92'	175.00'	16°00'57"	N74°02'28"W	48.76'
C27	81.06'	145.00'	32°01'55"	S82°02'57"E	80.01'
C28	48.92'	175.00'	16°00'57"	S89°56'34"W	48.76'
C29	158.39'	475.00'	19°06'21"	N88°23'53"E	157.66'
C30	61.59'	1025.00'	3°26'34"	S80°33'59"W	61.58'
C31	58.59'	975.00'	3°26'34"	S80°33'59"W	58.58'
C32	175.07'	525.00'	19°06'21"	N88°23'53"E	174.26'

CURVE TABLE					
CURVE #	LENGTH	RADIUS	DELTA	CHORD BEARING	CHORD DISTANCE
C33	34.94'	125.00'	16°00'57"	S89°56'34"W	34.83'
C34	109.02'	195.00'	32°01'55"	S82°02'57"E	107.60'
C35	34.94'	125.00'	16°00'57"	N74°02'28"W	34.83'
C36	19.57'	486.00'	2°18'27"	N08°12'11"E	19.57'
C37	5.92'	500.00'	0°40'40"	N09°01'05"E	5.92'
C38	14.00'	500.00'	1°36'16"	N07°52'37"E	14.00'
C39	55.68'	286.00'	11°09'20"	S87°37'37"E	55.60'
C40	61.14'	314.00'	11°09'20"	S87°37'37"E	61.04'
C41	39.43'	25.50'	88°35'38"	S53°39'14"W	35.62'
C42	40.68'	25.50'	91°24'22"	S36°20'46"E	36.50'
C43	39.43'	25.50'	88°35'38"	S53°39'14"W	35.62'
C44	6.79'	25.50'	15°15'21"	N89°40'38"W	6.77'
C45	32.64'	25.50'	73°20'17"	S46°01'33"W	30.46'
C46	100.21'	525.00'	10°56'10"	S87°31'02"E	100.05'
C47	4.94'	525.00'	0°32'23"	N86°44'42"E	4.94'
C48	69.91'	525.00'	7°37'48"	N82°39'36"E	69.86'
C49	44.20'	975.00'	2°35'51"	S80°08'38"W	44.20'
C50	14.38'	975.00'	0°50'43"	S81°51'55"W	14.38'
C51	2.86'	1025.00'	0°09'36"	S82°12'29"W	2.86'
C52	58.73'	1025.00'	3°16'58"	S80°29'11"W	58.72'
C53	37.29'	475.00'	4°29'53"	N81°05'39"E	37.28'
C54	36.42'	475.00'	4°23'36"	N85°32'23"E	36.41'
C55	84.68'	475.00'	10°12'51"	S87°09'23"E	84.57'
C56	1.74'	175.00'	0°34'06"	N66°19'03"W	1.74'
C57	26.08'	175.00'	8°32'24"	N70°52'17"W	26.06'
C58	21.10'	175.00'	6°54'28"	N78°35'43"W	21.09'
C59	25.52'	314.00'	4°39'23"	S84°22'39"E	25.51'
C60	35.62'	314.00'	6°29'57"	S89°57'19"E	35.60'
C61	5.74'	25.50'	12°53'32"	S75°36'11"E	5.73'
C62	34.94'	25.50'	78°30'50"	S29°54'00"E	32.27'
C63	31.01'	25.50'	69°40'40"	S43°57'18"W	29.14'
C64	8.53'	25.50'	19°09'23"	S88°22'21"W	8.49'

Line Table			Line Table		
Line #	Length	Direction	Line #	Length	Direction
L1	10.46	N81° 56' 05.31"E	L41	22.00	N07° 57' 02.79"E
L2	10.54	S66° 01' 59.72"E	L42	22.00	S07° 57' 02.79"W
L3	10.46	N81° 56' 05.31"E	L43	22.00	N07° 57' 02.79"E
L4	10.54	S66° 01' 59.72"E	L44	22.00	S07° 57' 02.79"W
L5	10.54	S66° 01' 59.72"E	L45	10.00	S07° 57' 02.79"W
L6	10.46	N81° 56' 05.31"E	L46	10.00	S07° 57' 02.79"E
L7	10.00	N07° 57' 02.79"E	L47	10.00	S07° 57' 02.79"W
L8	10.00	S07° 57' 02.79"W	L48	10.00	N07° 57' 02.79"E
L9	10.00	S07° 57' 02.79"W	L49	10.00	S07° 57' 02.79"W
L10	10.00	N07° 57' 02.79"E	L50	22.00	N07° 57' 02.79"E
L11	10.00	S02° 34' 12.79"W	L51	31.53	S07° 57' 02.79"W
L12	10.00	N09° 32' 13.21"W	L52	25.28	N09° 32' 13.21"W
L13	10.00	S09° 32' 13.21"E	L53	22.46	S09° 44' 02.04"E
L14	10.00	N03° 12' 17.21"W	L54	10.00	N09° 44' 02.04"W
L15	22.43	S09° 32' 13.21"E	L55	10.00	S09° 44' 02.04"E
L16	22.00	N07° 57' 02.79"E	L56	10.00	N07° 57' 02.79"E
L17	22.00	S07° 57' 02.79"W	L57	10.00	S07° 57' 02.79"E
L18	22.00	N07° 57' 02.79"E	L58	10.00	S03° 12' 17.21"E
L19	22.00	N80° 38' 35.19"W	L59	22.00	N09° 32' 13.21"W
L20	22.00	S80° 38' 35.19"E	L60	22.86	S02° 34' 12.79"W
L21	22.00	N80° 38' 35.19"W	L61	21.38	N02° 34' 12.79"E
L22	22.00	S80° 38' 35.19"E	L62	10.00	N02° 34' 12.79"E
L23	22.00	N07° 57' 02.79"E	L63	10.00	N07° 57' 02.79"E
L24	21.36	S07° 57' 02.79"W	L64	23.04	S07° 57' 02.79"W
L25	20.59	N07° 57' 02.79"E	L65	22.00	N03° 12' 17.21"W
L26	22.00	S07° 57' 02.79"W	L66	10.00	S07° 57' 02.79"W
L27	10.00	N80° 38' 35.19"W	L67	22.00	S07° 57' 02.79"E
L28	10.00	S80° 38' 35.19"E	L68	28.30	N07° 57' 02.79"E
L29	10.00	N80° 38' 35.19"W	L69	23.27	S07° 57' 02.79"W
L30	10.00	S80° 38' 35.19"E	L70	22.00	N07° 57' 02.79"E
L31	21.10	N07° 57' 02.79"E	L71	22.00	S03° 12' 17.21"E
L32	22.00	S07° 57' 02.79"W	L72	22.00	N03° 12' 17.03"W
L33	10.00	S07° 57' 02.79"W	L73	10.00	S03° 12' 17.03"E
L34	10.00	N07° 57' 02.79"E	L74	16.83	N82° 02' 57.21"W
L35	10.00	N07° 57' 02.79"E	L75	25.57	S81° 59' 38.08"E
L36	10.00	S0			