

.. ADDENDUM 3 TO IROQUOIS PHASE 1, 2, 3, 4 AND 5 DEVELOPMENT AGREEMENT

This addendum is entered into this 18th day of Aug, 2011 by and between Iroquois Phase 6 Corporation a Delaware Corporation and GCD Construction a Utah Corporation (hereinafter called "Developer") and Wasatch County, a political subdivision of the State of Utah (hereafter called the "County"). This addendum is to supplement, update and in some cases modify the Iroquois Phase 1, 2, 3, 4 and 5 Development Agreement executed by Deer Meadow Preserve, LLC, a Utah limited liability company as developer, and the County, on or about August 8, 2005, and recorded at the Wasatch County Recorder as Entry 286820, Book 775 and Pages 34—101 (the "Original Development Agreement") including the prior Addendum 1 to Iroquois Phase 1, 2, 3, 4, and 5 Development Agreement, executed by Deer Meadow Preserve, LLC as developer, and the County, on or about May 5, 2006, and recorded at the Wasatch County Recorder as Entry 304361, Book 872 and Pages 646-670 (the "Addendum 1", and including addendum 2 to Iroquois phase 1, 2, 3, 4, and 5 development agreement executed by Heritage Homes on or about September 18, 2007 and recorded at the Wasatch County recorder's Office as Entry 326143 Book 949 Pages 2242-2252. (all collectively with the Original Development Agreement, the "Subject Development Agreement.")

RECITALS

- A. This addendum is intended by the parties hereto to be an addendum to the Subject Development Agreement referenced above, however, if this addendum is ever held to be an invalid addendum to the Subject Development Agreement, the parties agree that this addendum may then stand on its own, and where necessary incorporate the provisions of said Subject Development Agreement into this addendum and bind the parties to the terms of this addendum.
- B. County is owner of real property totaling 14.61 acres within Wasatch County, State of Utah, commonly known as parcel D-1 of Iroquois phase 6. The Property is the property governed by the Subject Development Agreement.
- C. The County, acting pursuant to authority delegated to it under the laws of the State of Utah, and in furtherance of its land use policies, goals, and objectives, ordinances, and regulations, in the exercise of its discretion has elected to approve and enter into this addendum, modifying and supplementing the Subject Development Agreement.
- D. This agreement amends the second addendum to the Iroquois development agreement recorded September 18, 2007 which required the developer to construct the park in its entirety in accordance with the plan approved by the Wasatch County Council and attached as Exhibit A.
- E. The park was bonded for by the original developer, Wolper Construction. It was determined by the County that the developer was not willing and/or able to construct the park so the County started foreclosure proceedings on the bond. The bonding company agreed to provide the funds which totaled \$166,047 10.

- F. The Developer agrees to build the park for the \$166,047.10 amount if the County is willing to waive certain requirements as outlined in the agreement below.
- G. The terms of this addendum only apply to the Property as described in Exhibit A, and will not modify the Subject Development Agreement as it pertains to any other phase or property. Except as expressly modified by this addendum, the Subject Development Agreement will remain in full force and effect as to the Property.
- H. DEFINITIONS : Any term or phrase used in this Addendum that has its first letter capitalized shall have that meaning given to it in this section.

"County" shall mean Wasatch County and shall include, unless otherwise provided, any and all of the County's agencies, departments, officials, employees or agents.

"Developer" shall mean Iroquois Phase 6 Corporation and GCD Construction, Inc. and shall include Developer's successors in interest and assigns.

"Project" shall mean the Property and the development on the Property which is the subject of this Agreement, including all phases or plats regularly approved by the County and any ancillary and additional improvements or endeavors incident to the development of the Project.

"Property" shall mean the 14.61 acre park parcel and which are more particularly described in Exhibit A.

"Home Owners Association" shall mean the Home Owners Association for Parks Edge and The Retreats at Jordanelle.

Now therefore, in consideration of the mutual promises, covenants, and provisions set forth herein, the receipt and adequacy of which are hereby acknowledged, the Parties agree as follows:

AGREEMENT

1. Approval and Modification of Development Plan for Parcel D or the park parcel.

1.1 **Property Affected.** The Property shall be subject to the provisions of this addendum and shown in Exhibit A.

1.2 **Home Owners Association.** The Home Owners Association of the project shall maintain the park in all respects including but not limited to: maintenance of all landscaping, trails, bathrooms (as further noted below), all improvements, all water and sewer fees etc.

1.3 Developer shall construct the park in all respects as shown on the latest

approved park plan attached as Exhibit B. Except that it is agreed by all parties that all places requiring sod shall be seeded, all references to asphalt trails shall be crushed stone, and the fencing and stone columns at the entrances of the park shall be replaced with additional landscaping as referred to in Exhibit C.

1.4 The picnic area shall be comprised of a pavilion, as per Exhibit D, two picnic tables as per Exhibit E, two BBQ grills as per Exhibit F, and two trash receptacles in locations as per the attached site plan and as per Exhibit G.

1.5 Sewer and water has been stubbed into the property. The previous development agreement stated that the County may install a bathroom. At a time determined by the County, but no earlier than 50% completion of the cumulative number of ERU's for both projects (Retreat at Jordanelle – 133 ERU's and Parks Edge – 94.5 ERU's) a bathroom may be built at the sole discretion of the County. The County will provide \$10,000 and the Developer will provide the construction and any financial contribution over the \$10,000. The bathroom will be built adjacent to the parking area and pavilion. The design of a single stall unisex bathroom will be approved by the County.

1.6 All other aspects of the park plan are required to be installed in all respects including all trail connections to neighborhood areas, bridges over wetlands, irrigation etc. All grading will be done in conformance with the approved plan to create a usable irrigated grass area.

1.7 All park improvements including irrigation, plants, rock retaining walls, lawn seeding, trails and structures shall be warranted for labor and materials by the Developer for one year from the date of acceptance of the improvements by the County. The Developer shall separately warranty the native grass seeding for one year from the date of acceptance by the County which is expected to occur in Spring, 2012 when the native grass seeding germinates. The County agrees to release \$166,047.10 in funds in three draws as follows:

\$78,872.00 upon 50% completion

\$78,872.00 upon 100% completion and acceptance by the County of all items except native grasses.

\$8,303.10 retainage upon acceptance by the County of native grasses.

Checks should be made payable to:

General Construction and Development, Inc
870 West Carving Edge Court
Park City, UT 84060

The Developer shall provide partial and final release of liens to the County for the three draws shown above.

1.8 Building permit fees: Building inspection fees will be waived but not plan review fees.

1.9 No inspection fees and impact fees will be charged by the JSSD . JSSD has indicated that the existing 2" water line and meter, located in front of the clubhouse, which is dedicated solely for irrigation, provides sufficient water for irrigation of the park.

2 Successors and Assigns of Developer.

This addendum shall be binding on the successors and assigns of Developer, and assignment of the same shall be governed by the applicable provisions in the Subject Development Agreement, specifically Section 12.

Miscellaneous

3 Recordation of this Addendum to the Development Agreement

No later than ten (10) days after the County enters into this addendum, the County Clerk shall cause to be recorded, at Developer's expense, an executed copy of this addendum in the Official Records of the County of Wasatch.

4 Covenants to Run with the Land

The provisions of this addendum shall constitute real covenants, contract and property rights, and equitable servitudes, which shall run with all of the land subject to this addendum and the County shall have all the rights and remedies contained in the Subject Development Agreement to ensure performance of these obligations.

5 Incorporation of Recitals and Introductory Paragraph.

The Recitals contained in this addendum, and the introductory paragraph preceding the Recitals, are hereby incorporated into this addendum as if fully set forth herein.

IN WITNESS WHEREOF, this addendum has been entered into by and between Developer and the County as of the date and year first above written, WASATCH COUNTY:

Wasatch County Manager

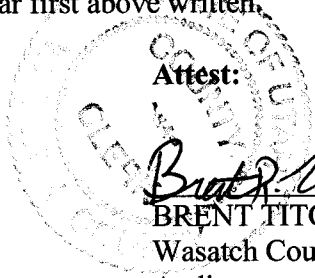

Attest:



BRENT TITCOMB,
Wasatch County Clerk
Auditor

STATE OF UTAH)
 ss:
COUNTY OF WASATCH)

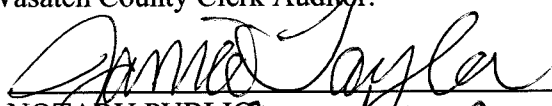
The foregoing instrument was acknowledged before me this 10th day of Aug, 2011, by Mike Davis, who executed the foregoing instrument in his capacity as the Wasatch County Manager and by Brent Titcomb, who executed the foregoing instrument in his capacity as the Wasatch County Clerk Auditor.

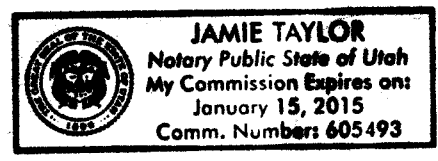

NOTARY PUBLIC
Residing at: Wasatch County

My Commission Expires:
Jan. 15, 2015

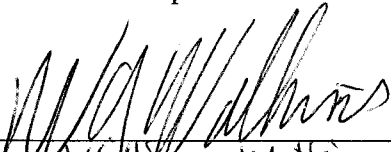

DEVELOPER:

Iroquois Phase 6 Corporation,
a Delaware Corporation

By: William Watkins
Its: Project Manager

STATE OF MARYLAND
COUNTY OF Carroll

The foregoing instrument was acknowledged before me this 27 day of July, 2011, by William Watkins, who executed the foregoing instrument in his capacity as Project Manager, Iroquois Phase 6 Corporation (Developer).

Brenda Holdridge
Expires: 11/14/2016

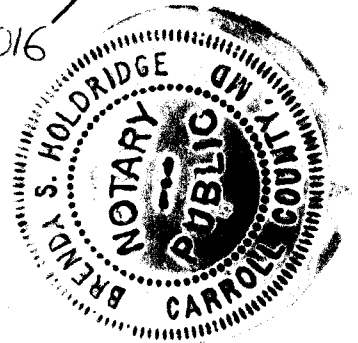

DEVELOPER:

Ent 371570 Bk 1039 Pg 1584

GCD Construction, INC.,
a Utah Corporation

MIKE STEWART
By: [Signature]
Its: PRESIDENT

STATE OF UTAH)
 :SS
COUNTY OF Utah)

The foregoing instrument was acknowledged before me this 1 day of ~~August~~, 2011, by Mike Stewart, who executed the foregoing instrument in his capacity as President, GCD Construction, Inc (Developer).

[Signature]
NOTARY PUBLIC
Residing at: Provo, Utah

My Commission Expires:
4-23-2012

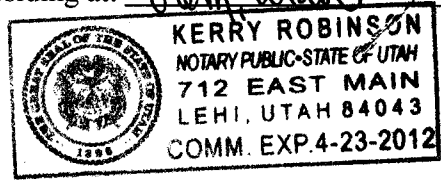
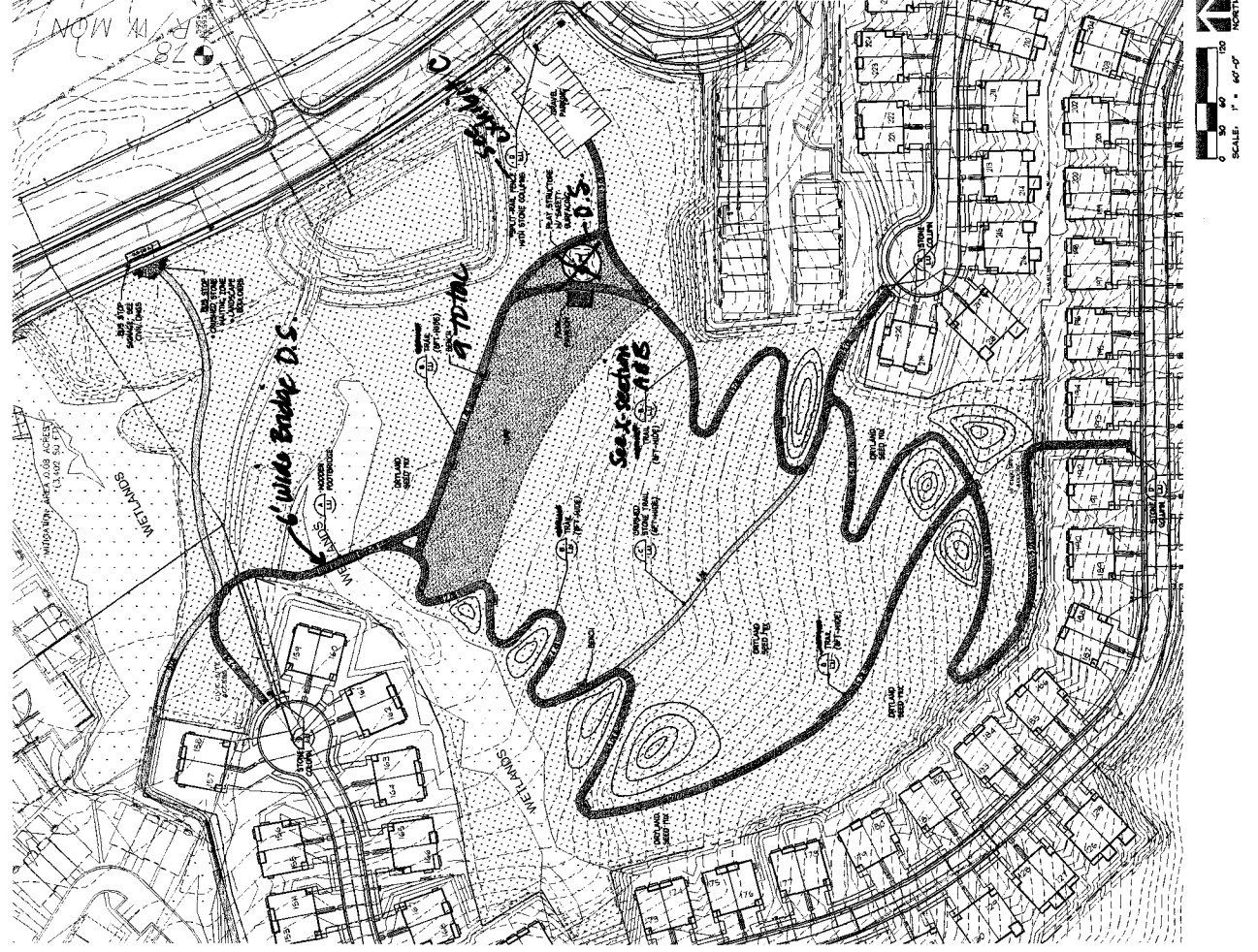

Exhibit A

consultant



- LEGEND**
- PROPERTY LINE
 - EXISTING LOT LINES
 - SEMI-TRAIL - ADA ACCESSIBLE
 - TRAIL WIDTH - 5.0'
 - TRAIL SLOPE - 5.0%
 - TRAIL SLOPE - 10.0% (MAX. FOR MAX. OF 50 FT.)
 - TRAIL SLOPE - 15.0% (MAX. FOR MAX. OF 50 FT.)
 - TRAIL SLOPE - 20.0% (MAX. FOR MAX. OF 50 FT.)
 - TRAIL SLOPE - 25.0% (MAX. FOR MAX. OF 50 FT.)
 - TRAIL SLOPE - 30.0% (MAX. FOR MAX. OF 50 FT.)
 - TRAIL SLOPE - 35.0% (MAX. FOR MAX. OF 50 FT.)
 - TRAIL SLOPE - 40.0% (MAX. FOR MAX. OF 50 FT.)
 - TRAIL SLOPE - 45.0% (MAX. FOR MAX. OF 50 FT.)
 - TRAIL SLOPE - 50.0% (MAX. FOR MAX. OF 50 FT.)
 - TRAIL SLOPE - 55.0% (MAX. FOR MAX. OF 50 FT.)
 - TRAIL SLOPE - 60.0% (MAX. FOR MAX. OF 50 FT.)
 - TRAIL SLOPE - 65.0% (MAX. FOR MAX. OF 50 FT.)
 - TRAIL SLOPE - 70.0% (MAX. FOR MAX. OF 50 FT.)
 - TRAIL SLOPE - 75.0% (MAX. FOR MAX. OF 50 FT.)
 - TRAIL SLOPE - 80.0% (MAX. FOR MAX. OF 50 FT.)
 - TRAIL SLOPE - 85.0% (MAX. FOR MAX. OF 50 FT.)
 - TRAIL SLOPE - 90.0% (MAX. FOR MAX. OF 50 FT.)
 - TRAIL SLOPE - 95.0% (MAX. FOR MAX. OF 50 FT.)
 - TRAIL SLOPE - 100.0% (MAX. FOR MAX. OF 50 FT.)

NOTES

- TRAILS LOCATED WITHIN THE PARK SHALL CONFORM TO WASHO COUNTY TRAIL STANDARDS AND DESIGN GUIDELINES.
- TRAILS SHALL BE LOCATED DEEPER THAN THE DEPTH OF THE SOIL OR AS SHOWN ON PLAN.
- GATES OR BARRIERS SHALL BE LOCATED AT ACCESS POINTS TO CONTROL ACCESS FOR NOTIFIED VEHICLES.
- WHERE REQUIRED, TEMPORARY FENCING SHALL BE USED IN ORDER TO PROTECT ECOLOGICALLY SENSITIVE AREAS DURING CONSTRUCTION.

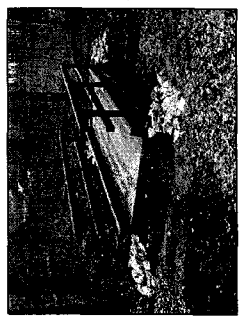

*Bridges over Wetlands
 Crushed Stone 1/2"*

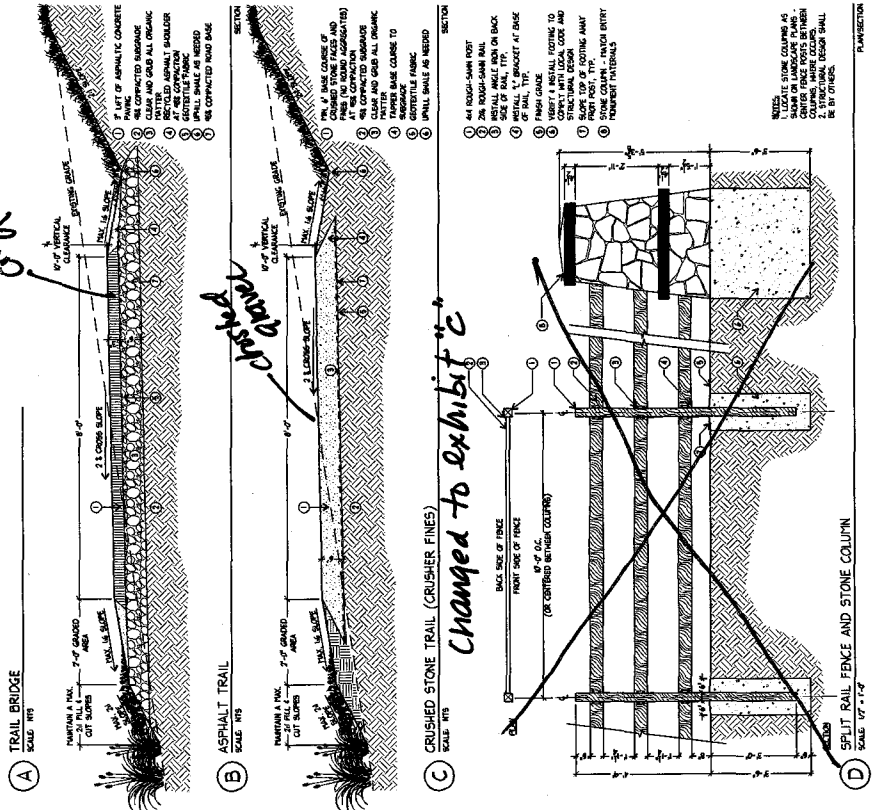
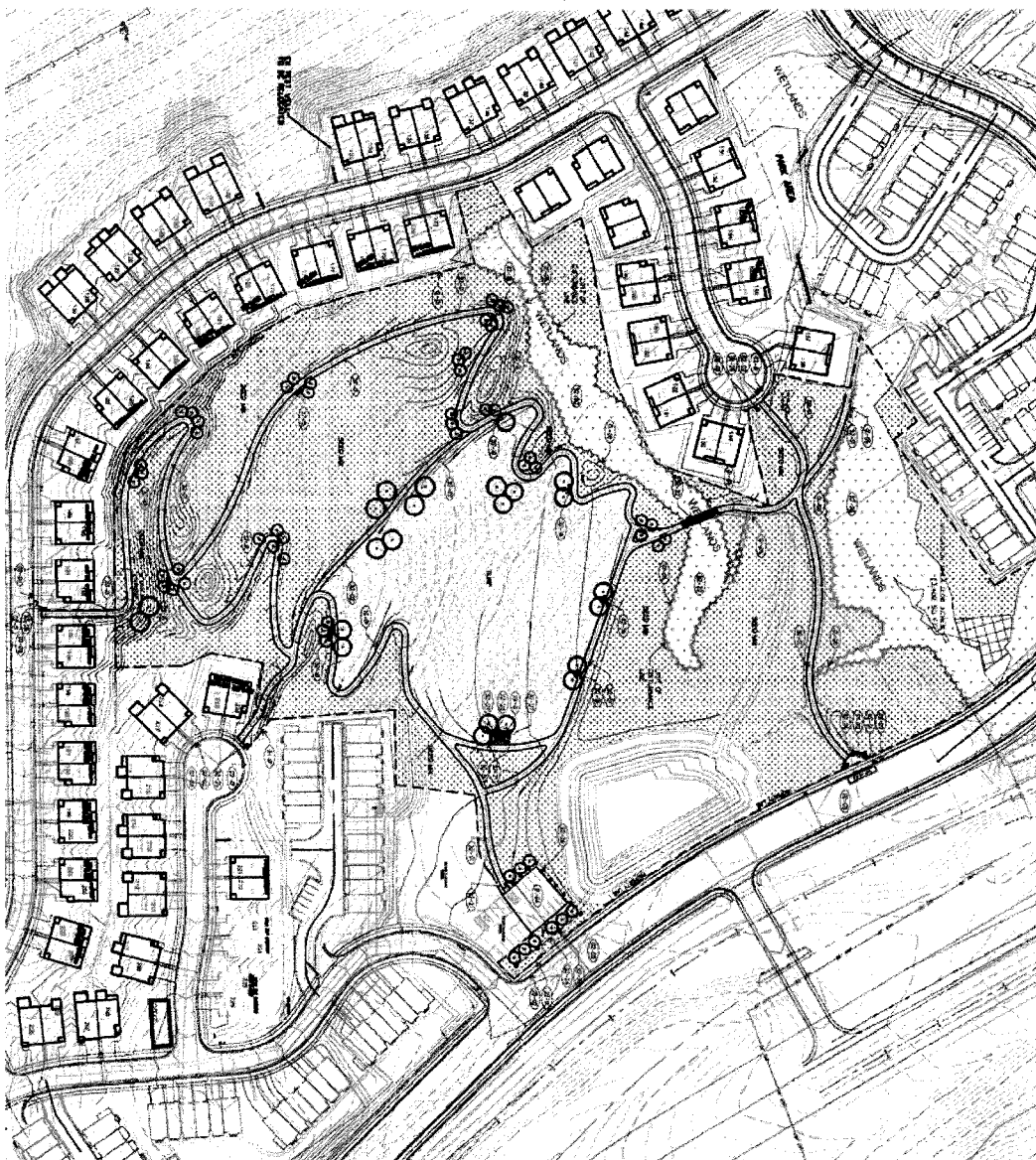

Exhibit "B" Latest Approved Park Plan



LEGEND	
	UTILITY LINE
	EASEMENT
	PROPERTY LINE
	SURVEY LINE
	BOUNDARY LINE
	SURVEY POINT
	SURVEY STATION
	SURVEY MARKER
	SURVEY LINE
	SURVEY POINT
	SURVEY STATION
	SURVEY MARKER
	SURVEY LINE
	SURVEY POINT
	SURVEY STATION
	SURVEY MARKER
	SURVEY LINE
	SURVEY POINT
	SURVEY STATION
	SURVEY MARKER
	SURVEY LINE
	SURVEY POINT
	SURVEY STATION
	SURVEY MARKER
	SURVEY LINE
	SURVEY POINT
	SURVEY STATION
	SURVEY MARKER

PLANTING SCHEDULE

PLANTING NOTES

KEY NOTES

REFERENCE NOTE SCHEDULE

SCALE

DATE

Sililo Design Inc

1000 West 12th Street, Suite 1000
 Portland, Oregon 97204
 Phone: 503.241.1200
 Fax: 503.241.1201
 Email: info@sililo.com

JORDANVILLE RETIREMENT PARK

WARREN COUNTY, ILL.

OVERALL PLANTING PLAN

L-P0

Exhibit "C" Entrance Landscaping

TREE PLAN

EXISTING PARKING

TREES

SYM	SPECIES	SIZE	#
S	COLORADO SPRUCE	6-8'	1
A	AUSTRIAN PINE	6-8'	3
B	QUINQUE-LOBED	12"	75
C	QUINQUE-LOBED	12"	6
M	ROYAL HEDERA ACORN	12"	4

JORDANELLE RETREAT PARK

BEATT INC.

SHRUB PLAN

PARKING

SHRUBS

SYM	SPECIES	SIZE	#
•	TREES - SEE TREE PLAN		
G	GREENLOW GUMMEL	24"	10
C	CHERRY CHERRY	24"	10
D	REDTILE HORNWOOD	12"	14
F	BARBET WOOD	12"	13
GM	GREEN GUMMEL	12"	22
S	SMOOTH GUMMEL	24"	2

JORDANELLE RETREAT PARK

BEATT INC.

TREE PLAN

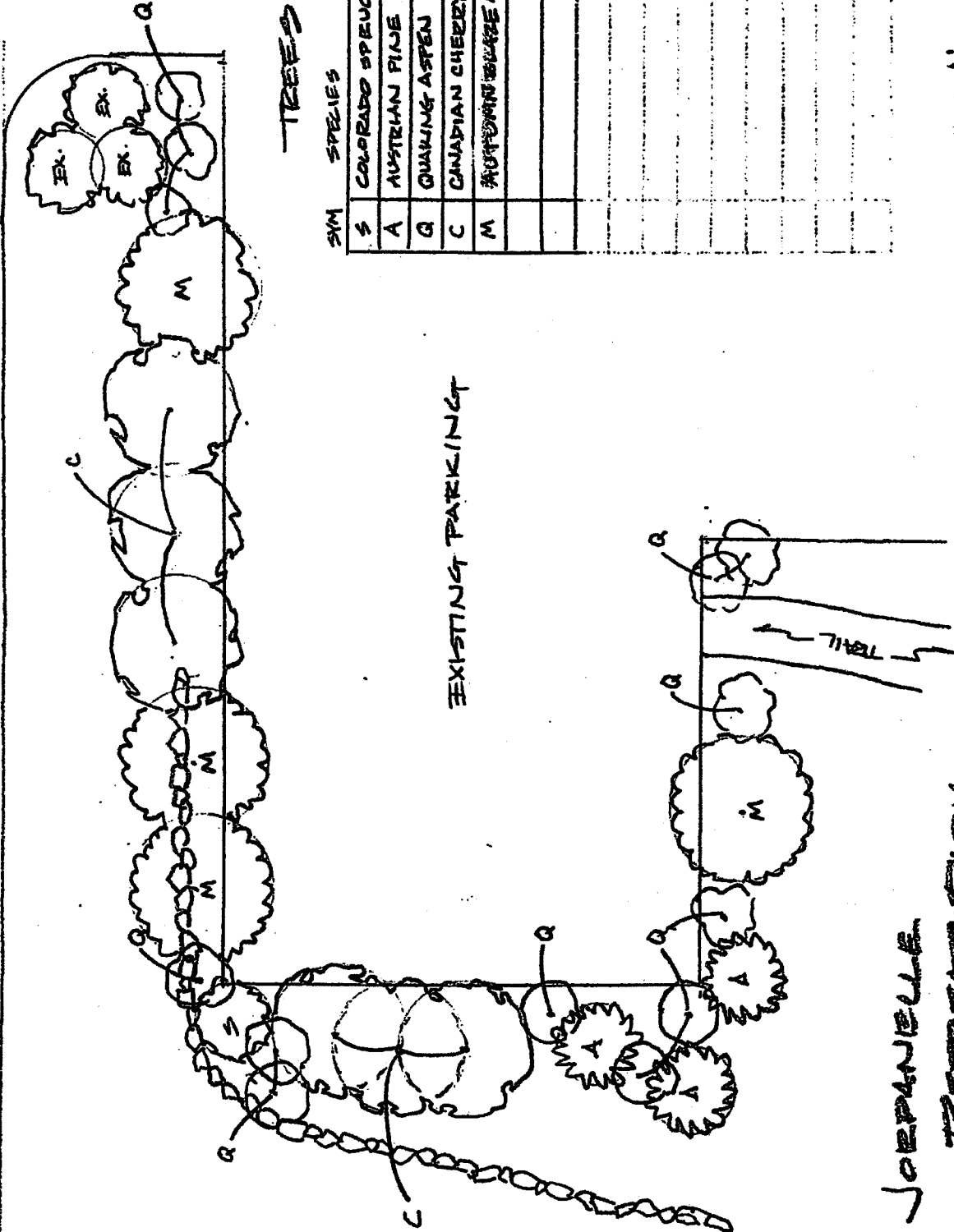

TREES

SYM	SPECIES	SIZE	#
S	COLORADO SPRUCE	6-8'	1
A	AUSTRIAN PINE	6-8'	3
G	QUAKING ASPEN	1 1/2"	13
C	CANADIAN CHERRY	1 1/2"	6
M	HUTTONS BLUE MAPLE	1 1/2"	4

BRAATT INC.

JAPONNELLE
RETREAT PARK

SHRUB PLAN

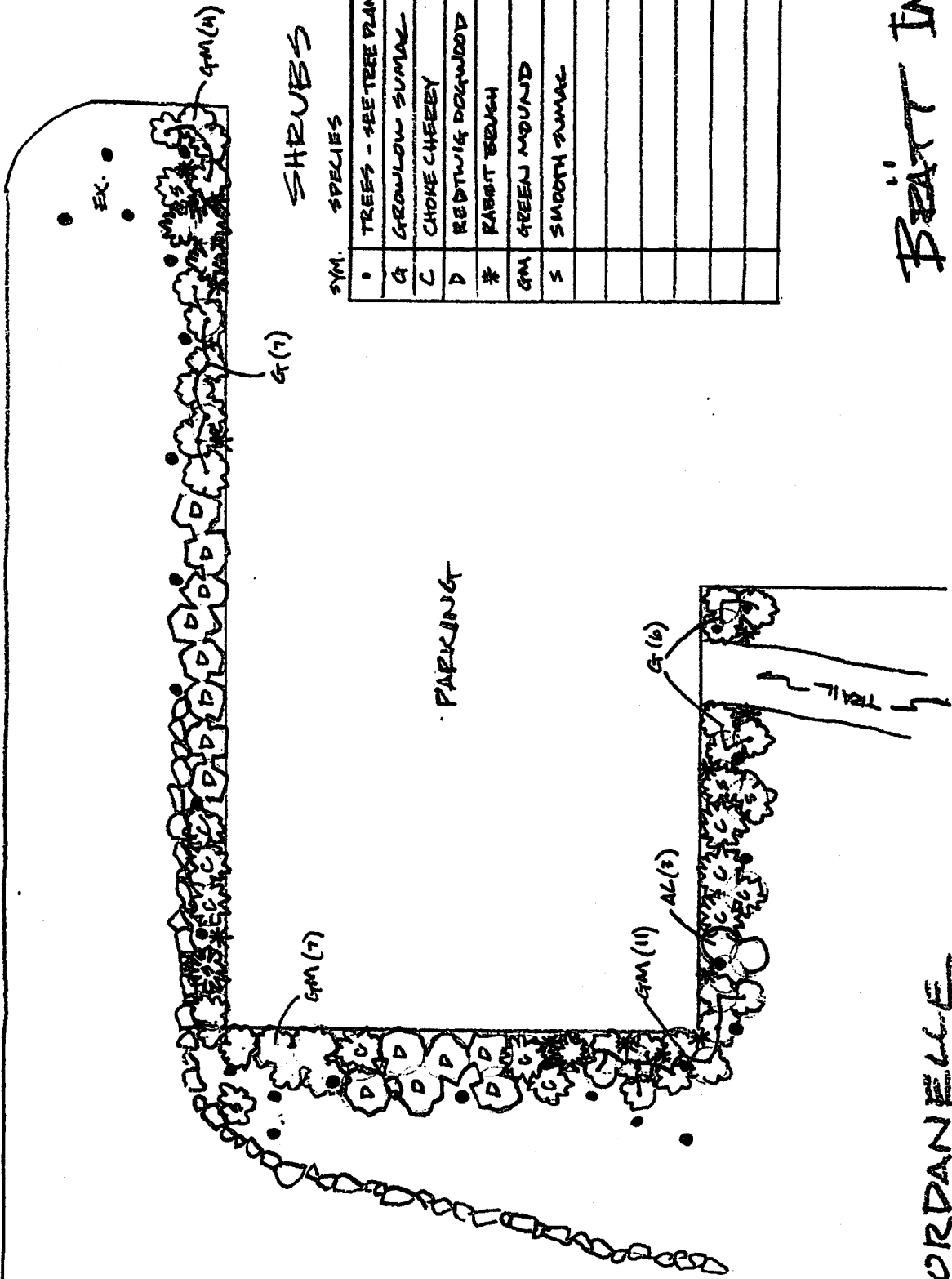

SHRUBS

SYM.	SPECIES	SIZE	#
T	TREES - SEETREE PLAN	VAR.	30
G	GROWLOW SUMAC	5G	13
C	CHOKE CHEEY	5G	13
D	REDWIG DOGWOOD	1G	14
R	RABBIT BUSH	1G	13
GM	GREEN MOUND	1G	22
S	SMOOTH SUMAC	5G	5

BRATT INC.

JORDANELLE
RETREAT PARK

Exhibit "D" Picnic pavilion



Exhibit "E" Picnic Tables (2)

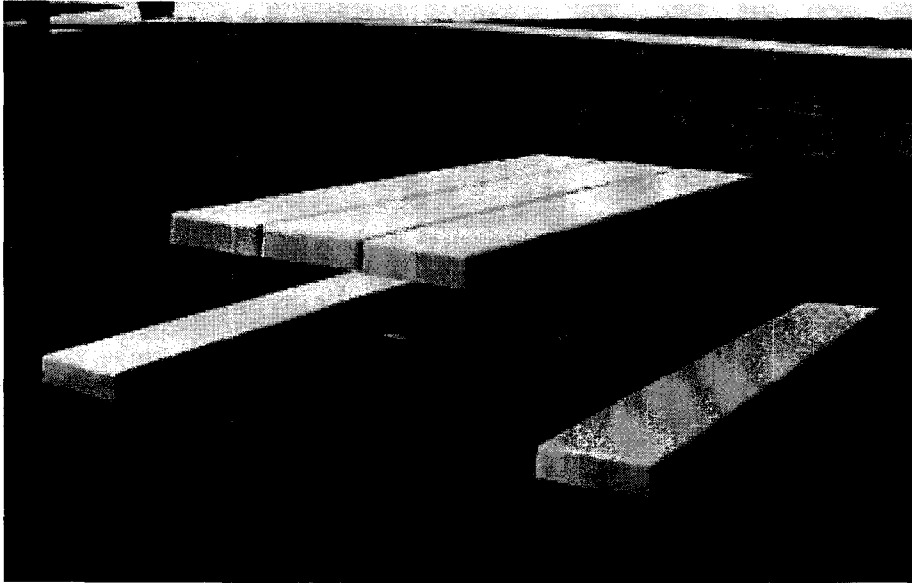

Exhibit "F" BBQ Grills (2)

FINISH IS HIGH HEAT RESISTANT BLACK ENAMEL
COOKING GRATE HAS 4 LEVELS OF ADJUSTMENT
AND CANNOT BE REMOVED FROM THE GRILL BODY



12GR-00008

Santa Barbara Pedestal Grill, Black Enamel
Finish, 2 3/8" O.D. Pedestal

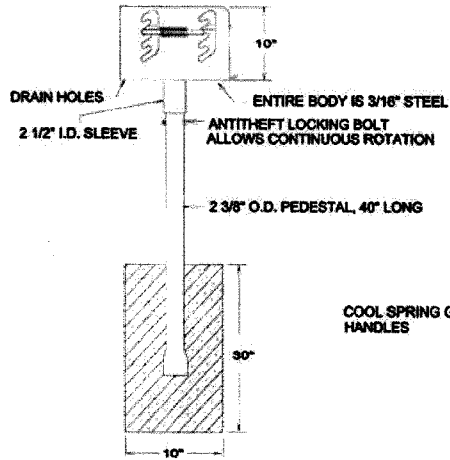

HANDLES ARE 5/8" ROD
COOKING SURFACE IS
1/2" RODS ON 1" CENTERS
300 SQ. IN.

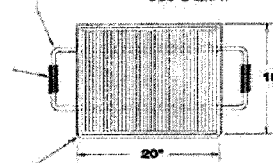

COOL SPRING GRIP
HANDLES

NOTE: THE SIZE OF THE FOOTING
IS ONLY A SUGGESTION
YOUR LOCAL SOIL CONDITIONS
SHOULD DETERMINE WHAT IS
NECESSARY

Exhibit "G" Trash Receptacles (2)



Recycled Plastic Slat Design Round Receptacles

Receptacles include rigid plastic liner and lid

Attractive slatted design in popular gallon capacity models

Also handy as recycling bins

Equally useful indoors and outdoors

Recycled plastic lumber never needs painting

Rigid HDPE flat lid with 10" dia.

opening on top load models

Ships fully assembled

**Optional Inground Post Mount Kit

Keeps trash receptacle off turf & securely in place

Easy to mow & weed-whack around

2' post - Installation of post is 18" inground, 6" above ground

Made specifically for the Round Slatted Trash Receptacles

Available for 5, 10, 20 & 32 gallon receptacle models

Includes hardware; assembly required

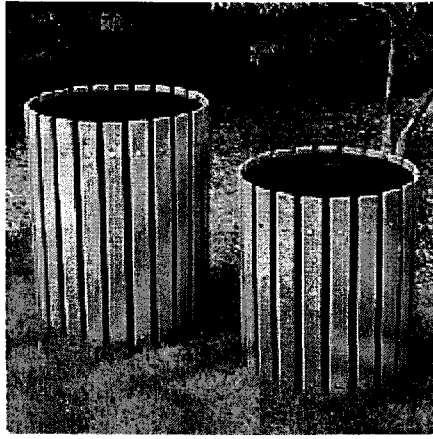

Enlarge

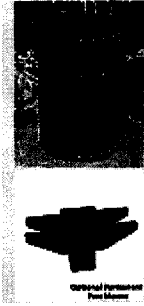

Available Colors

Colors may vary by computer monitor, printer, dye lot



Black



Brown



Cedar



Desert Tan



Evergreen



Gray

25-Year Unconditional Guarantee

Usually Ships in 3 to 4 Weeks

150/1000



BarcoBoard™ Pedestal Tables

NEW!

Ideal for resorts, schools, parks, break areas & more

Attractive wood grain finish never needs painting

No rotting, splintering or breaking with recycled plastic boards

Lightweight & engineered to resist sagging

Assembly hardware included

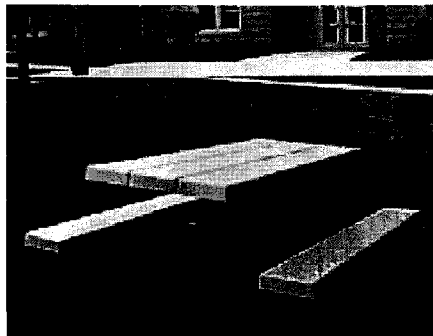

Enlarge



Guaranteed Against Breakage for 50 Years!

Usually Ships in 3 to 4 Weeks



Top / Seat Colors

Colors may vary by computer monitor, printer, dye lot



Cedar



Desert Tan

Frame Colors

Colors may vary by computer monitor, printer, dye lot



Black



Galvanized

arcoBoard™ Steel Frame Benches

This bench is ideal for resorts, campgrounds, parks, picnic groves, break areas & more
Recycled plastic boards will not rot, splinter or break

Woodgrain finish never needs painting

Lightweight & engineered to resist sagging

1-1/2" OD steel frames

Assembly required, hardware included

A maintenance-free future, a perfect low-cost solution

Guaranteed against breakage for 50 years!

 Usually Ships in 3 to 4 Weeks

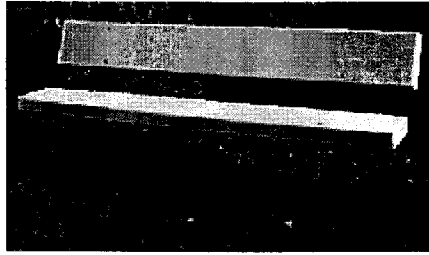

 **Enlarge**



Seat / Back Colors

Colors may vary by computer monitor, printer, dye lot



Desert Tan Cedar

Frame Colors

Colors may vary by computer monitor, printer, dye lot







Black Galvanized



Inground Picture not shown.

PLANT SCHEDULE

TREES	BOTANICAL	COMMON	CONT GAL SIZE	QTY
	<i>Fraxinus mandshurica</i>	Mancana' Manchurian Ash	B & B 2"	14
	<i>Picea pungens</i>	Colorado Spruce	B & B 6-8H 12	
	<i>Populus tremuloides</i>	Quaking Aspen---	B & B 2"	55
GROUND COVERS	BOTANICAL	COMMON	CONT	QTY
	Seed Mix	(see seed mix legend below)	seed	176,576 sf
	Turf Sod	Drought tolerant bluegrass blend sod	sod	105,665 sf

SEED MIX LEGEND *

BOTANICAL NAME	COMMON NAME	BOTANICAL NAME	COMMON NAME	PERCENTAGE
MILDFLOWER/GRASS SEED MIX	310,410 SF			100%
Rock Mtn. Milkflower Seed Mix				70%
Annuals		Perennials (cont.)		
<i>Centaurea cyanus</i>	Bachelor Button	<i>Coreopsis lanceolata</i>	Lance-leaved Coreopsis	
<i>Cheiranthus allionii</i>	Milkflower	<i>Echinacea purpurea</i>	Purple Coneflower	
<i>Coreopsis tinctoria</i>	Plains Coreopsis	<i>Erigeron speciosus</i>	Aspen Daisy	
<i>Eriogonum umbellatum</i>	Sulphur Cosmos	<i>Gaillardia aristata</i>	Blanket Flower	
<i>Gaillardia pulchella</i>	Firewheel	<i>Iris missouriensis</i>	Rocky Mountain Iris	
<i>Gilia capitata</i>	Gilia Species	<i>Linum lewisii</i>	Lewis Blue Flax	
<i>Linanthus grandiflorus</i>	Mountain Phlox	<i>Lupinus Species</i>	Lupine Species	
<i>Linum grandiflorum rubrum</i>	Scarlet Flax	<i>Oenothera occidentalis</i>	Sweet Annie	
<i>Papaver rhoeas</i>	Baby Snapdragon	<i>Papaver nudicaule</i>	Island Poppy	
<i>Phlox drummondii</i>	Shirley Poppy	<i>Penstemon species</i>	Penstemon Species	
Perennials	Drummond Phlox	<i>Ratibida columnaris</i>	Prairie Coneflower	
<i>Agilegia coerulea</i>	Colorado Columbine	<i>Rudbeckia hirta</i>	Mexican Hat	
<i>Aster Species</i>	Aster Species	<i>Viguiera hirta</i>	Black-eyed Susan	
<i>Castilleja linariaefolia</i>	Panicle Bush		Showy Goldeneye	
Grasses				
<i>Bromus marginatus</i>	Mountain Brome			30%
<i>Elymus glaucus</i>	Blue Wild Rye			10%
<i>Festuca ovina</i>	Sheep Fescue			8%
<i>Poa alpina</i>	Alpine Bluegrass			2%
<i>Triticum aestivum x Elytrigia elongata</i>	Quickgrass			1%
				9%

* CONTACT DARYLE BENNETT AT GRANITE SEED FOR SEED MIXES- 801-768-4422

Phase 1 description

ROAD WAY BOUNDARY DESCRIPTION

BEGINNING at a point that is S 89°58'18" E 585.59 feet along the Section Line and N 00° 01'42" E 165.45 feet from the Northwest Corner of Section 6, township 2 South, Range 5 East, Salt Lake Base and Meridian; and running thence N 06°13'06" W 114.99 feet to a point on a 936.00' radius curve to the right; thence along arc of said curve 232.93 feet through a delta of 14°15'31" (chord bears N 00°54'39" E 232.33 feet); thence N 08°02'25" E 204.36 feet more or less to the County Line, thence along said County Line N 82°44'12" E 74.65 feet; thence S 08°02'25" W 224.06 feet to a point on a 864.00' radius curve to the left; thence along said curve 215.01 feet through a delta of 14°15'31" (chord bears S 00°54'39" W 214.46 feet); thence S 06°13'06" E 114.99 feet to a point on a 511.00' radius curve to the right; thence along arc of said curve 278.72 feet through a delta of 31°15'06" (chord bears S 09°24'27" W 275.28 feet); thence S 25°02'00" W 100.64 feet to a point on a 439.00' radius curve to the left; thence along arc of said curve 164.96 feet through a delta of 21°31'46" (chord bears S 14°16'07" W 163.99 feet); thence S 03°30'14" W 202.39 feet to a point on a 514.00' radius curve to the left; thence along arc of said curve 167.74 feet through a delta of 18°41'54" (chord bears S 05°50'43" E 167.00 feet); thence S 15°11'40" E 289.35 feet to a point on a 964.00' radius curve to the left; thence along arc of said curve 300.24 feet through a delta of 17°50'41" (chord bears S 24°07'00" E 299.03 feet); thence S 33°02'21" E 287.52 feet to a point on a 256.00' radius curve to the right; thence along arc of said curve 289.59 feet through a delta of 64°48'46" (chord bears S 00°37'58" E 274.39 feet); to a point on a 257.08' radius curve to the right; thence along arc of said curve 47.26 feet through a delta of 10°31'59" (chord bears S 30°55'32" W 47.19 feet); to a point on a 261.00' radius curve to the right; thence along arc of said curve 25.61 feet through a delta of 05°37'18" (chord bears S 45°00'04" W 25.60 feet); to an existing UDOT right of way line, thence along said right of way line N 30°14'22" W 84.70 feet to a point on a 179.54' radius non-tangent curve to the left; thence along arc of said curve 33.37 feet through a delta of 10°39'01" (chord bears N 45°34'30" E 33.33 feet); to a point on a 184.00' radius curve to the left; thence along arc of said curve 208.14 feet to a delta of 64°48'46" (chord bears N 00°37'58" W 197.22 feet); thence N 33°02'21" W 287.52 feet to a point on a 1036.00' radius curve to the right; thence along arc of said curve 322.66 feet through a delta of 17°50'41" (chord bears N 24°07'00" W 321.36 feet); thence N 15°11'40" W 289.35 feet to a point on a 586.00' radius curve to the right; thence along arc of said curve 191.24 feet through a delta of 18°41'54" (chord bears N 05°50'43" W 190.39 feet); thence N 03°30'14" E 202.39 feet to a point on a 511.00' radius curve to the right; thence along arc of said curve 192.01 feet through a delta of 21°31'46" (chord bears N 14°16'07" E 190.88 feet); thence N 25°02'00" E 100.64 feet to a point on a 439.00' radius curve to the left; thence along arc of said curve 239.45 feet through a delta of 31°15'06" (chord bears N 09°24'27" E 236.49 feet) to the point of BEGINNING. Parcel contains 4.41 acres.

PHASE 2 BOUNDARY DESCRIPTION

BEGINNING at a point that is N 89°58'18" W 1319.52 feet along the Section Line from the North Quarter Corner of Section 6, Township 2 South, Range 5 East, Salt Lake Base and Meridian, and running thence S 00° 09'57" E 2513.27 feet to a UDOT right-of-way line, thence along said right-of-way line the following 3 calls; 1) thence N 32°49'54" W 420.67 feet, 2) thence N 40°57'51" W 372.21 feet, 3) thence N 30°14'22" W 42.08 feet to a point on a 261.00' radius non-tangent curve to the left, thence along arc of said curve 25.61 feet through a delta of 05°37'18" (chord bears N 45°00'04" E 25.60 feet) to a point on a 257.08' radius non-tangent curve to the left, thence along arc of said curve 47.26 feet through a delta of 10°31'59" (chord bears N 30°55'32" E 47.19 feet) to a point on a 256.00' radius non-tangent curve to the left, thence along arc of said curve 289.59 feet through a delta of 64°48'46" (chord bears N 00°37'58" W 274.39 feet), thence N 33°02'21" W 287.52 feet to a point on a 964.00' radius curve to the right; thence along arc of said curve 300.24 feet through a delta of 17°50'41" (chord bears N 24°07'00" W 299.03 feet); thence N 15°11'40" W 289.35 feet to a point on a 514.00' radius curve to the right; thence along arc of said curve 167.74 feet through a delta of 18°41'54" (chord bears N 05°50'43" W 167.00 feet); thence N 03°30'14" E 202.39 feet to a point on a 439.00' radius curve to the right; thence along arc of said curve 164.96 feet through a delta of 21°31'46" (chord bears N 14°16'07" E 163.99 feet); thence N 25°02'00" E 100.64 feet to a point on a 511.00' radius curve to the left; thence along arc of said curve 104.26 feet through a delta of 11°41'25" (chord bears N 19°11'18" E 104.08 feet) to the Section Line; thence along the Section Line S 89°58'18" E 688.89 feet to the point of BEGINNING. Parcel contains 31.86 acres.



PHASE 3 BOUNDARY DESCRIPTION

BEGINNING at a the Northwest Corner of Section 6, Township 2 South, Range 5 East, Salt Lake Base and Meridian and running thence along the Section Line S 89°58'18" E 572.13 feet to the Browns Canyon Right of Way and running thence along said right of way for the following ten (10) courses: 1) thence along an arc of a non-tangent 439.00' radius curve to the right 72.45 feet through a delta of 09°27'19" (chord bears S 28°18'20" W 72.36 feet), 2) thence S 25°02'00" W 100.64 feet to a point on a 511.00' radius curve to the left; 3) thence along arc of said curve 192.01 feet through a delta of 21°31'46" (chord bears S 14°16'07" W 190.88 feet); 4) thence S 03°30'14" W 202.39 feet to a point on a 586.00' radius curve to the left; 5) thence along arc of said curve 191.24 feet through a delta of 18°41'54" (chord bears S 05°50'43" E 190.39 feet), 6) thence S 15°11'40" E 289.35 feet to a point on a 1036.00' radius curve to the left; 7) thence along arc of said curve 322.66 feet through a delta of 17°50'41" (chord bears S 24°07'00" E 321.36 feet); 8) thence S 33°02'21" E 287.52 feet to a point on a 184.00' radius curve to the right; 9) thence along arc of said 208.14 feet through a delta of 64°48'46" (chord bears S 00°37'58" E 197.22 feet) to a non tangent 179.54' radius curve to the right, 10) thence along arc of said curve 33.37 feet through a delta of 10°39'01" (chord bears S 45°34'30" W 33.33 feet) to the UDOT right of way; thence along said row the following 5 calls; 1) thence N 29°01'18" W 75.40 feet, 2) thence N 36°32'18" W 663.67 feet to a point on a 2109.86' radius curve to the left, 3) thence along arc of said curve 437.59 feet through a delta of 11°53'00" (chord bears N 49° 51'33" W 436.81 feet), 4) thence N 48°21'45" W 173.93 feet to a point on a 2139.86' radius curve to the left; 5) thence along arc of said curve 700.85 feet through a delta of 18°45'56" (chord bears N 69°49'44" W 697.72 feet; thence N 03°37'00" W 534.05 feet to the Section line, thence along said section line S 89°59'51" E 777.54 feet to the point of BEGINNING. Parcel contains 25.45 acres.

PHASE 4 BOUNDARY DESCRIPTION

A parcel of land located in the East half of Section 1, Township 2 South, Range 4 East, and in the Northwest Quarter of Section 6, Township 2 South, Range 5 East, Salt Lake Base and Meridian, more particularly described as follows:

Beginning at a point on the westerly line of the Wasatch County line, which point is 420.54 feet, North 89°50'20" West along the East-West Quarter section line and 736.05 feet, South 00°09'40" West from the brass cap monument found marking the West Quarter corner of said Section 6 (basis of bearings being South 00°44'47" East, 2643.77 feet along the section line between the brass cap monuments found marking the Northwest and West Quarter corners of said Section 6), and running thence along said westerly line the following four (4) courses: (1) North 29°19'09" West, 334.05 feet; (2) North 07°48'30" West, 1031.06 feet; (3) North 30°03'00" East, 491.00 feet; (4) North 15°43'00" West, 623.18 feet to the southwesterly line of Highway 248 and a 1679.86-foot curve to the right (center bears South 18°24'52" West); thence along said southwesterly line the following five (5) courses: (1) southeasterly 1058.71 feet along the arc of said curve through a central angle of 36°06'36" (chord bears South 53°31'50" East, 1041.28 feet); (2) South 31°53'30" East, 311.66 feet; (3) South 42°52'21" East, 264.22 feet to a 360.24-foot radius curve to the right (radius bears South 26°14'55" West); (4) southeasterly 137.82 feet along the arc of said curve through a central angle of 21°55'15" (chord bears South 52°47'28" East, 136.98 feet); (5) South 30°11'46" East, 147.37 feet to the northerly line of the Rail Trail and a 647.96-foot radius curve to the left (center bears South 23°55'19" West); thence along said line the following five (5) courses: (1) southwesterly 1206.51 feet along the arc of said curve through a central angle of 106°41'07" (chord bears South 60°34'45" West, 1039.61 feet); (2) South 07°14'13" West, 244.70 feet to a 641.78-foot radius curve to the right (center bears North 82°45'47" West); (3) southwesterly 156.77 feet along the arc of said curve through a central angle of 13°59'45" (chord bears South 14°14'05" West, 156.38 feet); (4) North 68°45'01" West, 66.00 feet to a 575.78-foot radius curve to the right (center bears North 68°46'09" West); (5) southwesterly 198.56 feet along the arc of said curve through a central angle of 19°45'32" (chord bears South 31°06'37" West, 197.58 feet) to the point of beginning.

Contains 6 lots, 32.70 acres, more or less

PHASE 5 BOUNDARY DESCRIPTION

A parcel of land located in the Southeast Quarter of Section 1, Township 2 South, Range 4 East, and in the West Half of Section 6, Township 2 South, Range 5 East, Salt Lake Base and Meridian, more particularly described as follows:

Beginning at a point on the westerly line of the Wasatch County line and the southeast line of the Rail Trail and a 791.78-foot radius curve to the left (center bears North 43°29'43" West), which point is 309.62 feet, North 89°50'20" West along the East-West Quarter section line and 932.45 feet, South 00°09'40" West from the brass cap monument found marking the West Quarter corner of said Section 6 (basis of bearings being South 00°44'47" East, 2643.77 feet along the section line between the brass cap monuments found marking the Northwest and West Quarter corners of said Section 6), and running thence along said Rail Trail the following three (3) courses: (1) northeasterly 542.65 feet along the arc of said curve through a central angle of 39°16'04" (chord bears North 26°52'15" East, 532.09 feet); (2) North 07°14'13" East, 244.70 feet to a 497.96-foot radius curve to the right (radius bears South 82°45'48" East); (3) northeasterly 1202.30 feet along the arc of said curve through a central angle of 138°20'16" (chord bears North 76°24'20" East, 930.82 feet); thence North 89°41'32" East, 35.12 feet; thence South 24°51'03" East, 804.11 feet; thence South 65°11'03" West, 48.84 feet; thence North 49°36'37" West, 330.73 feet; thence South 40°23'23" West, 72.00 feet to a 16.00-foot radius curve to the left (radius bears South 40°23'23" West); thence southwesterly 25.74 feet along the arc of said curve through a central angle of 92°11'30" (chord bears South 84°17'38" West, 23.06 feet); thence South 38°11'53" West, 30.42 feet to the point of curvature with a 275.00-foot radius curve to the right; thence southwesterly 99.39 feet along the arc of said curve through a central angle of 20°42'30" (chord bears South 48°33'08" West, 98.85 feet); thence South 58°54'23" West, 246.66 feet to the point of curvature with a 225.00-foot radius curve to the left; thence southwesterly 147.20 feet along the arc of said curve through a central angle of 37°29'06" (chord bears South 40°09'50" West, 144.59 feet); thence South 21°25'17" West, 70.04 feet to the point of curvature with a 275.00-foot radius curve to the right; thence southwesterly 168.46 feet along the arc of said curve through a central angle of 35°05'51" (chord bears South 38°58'12" West, 165.83 feet); thence South 56°31'08" West, 22.50 feet to the point of curvature with a 15.50-foot radius curve to the left; thence southwesterly 24.35 feet along the arc of said curve through a central angle of 90°00'00" (chord bears South 11°31'08" West, 21.92 feet); thence South 56°31'08" West, 480.55 feet to a point on said westerly line of the Wasatch County line; thence along said line the following three (3) courses: (1) North 24°45'20" West, 235.53 feet; (2) North 24°29'41" West, 148.30 feet; (3) North 29°19'09" West, 146.95 feet to the point of beginning.

Contains 29.29 acres, more or less.