

EAGLE POINT TOWNHOMES PLAT "D"

A RESIDENTIAL SUBDIVISION

LOCATED IN THE NORTHEAST QUARTER OF SECTION 13 AND THE SOUTHEAST QUARTER OF SECTION 12, TOWNSHIP 6 SOUTH, RANGE 2 WEST, SALT LAKE BASE AND MERIDIAN

EAGLE MOUNTAIN CITY, UTAH COUNTY, UTAH

SHEET 1 OF 2

VICINITY MAP



SURVEYOR'S CERTIFICATE
 I, KAGAN M. DIXON, DO HEREBY CERTIFY THAT I AM A PROFESSIONAL LAND SURVEYOR, AND THAT I HOLD LICENSE NO. 9061091 AS PRESCRIBED UNDER THE LAWS OF THE STATE OF UTAH. I FURTHER CERTIFY THAT BY THE AUTHORITY OF THE OWNERS, I HAVE MADE A SURVEY OF THE TRACT OF LAND SHOWN ON THIS PLAT AND DESCRIBED BELOW, AND HAVE SUBDIVIDED SAID TRACT OF LAND INTO LOTS, STREETS, AND EASEMENTS TO BE KNOWN AS EAGLE POINT TOWNHOMES PLAT "D" AND THE SAME HAS BEEN CORRECTLY SURVEYED AND STAKED ON THE GROUND AS SHOWN ON THIS PLAT AND THAT THIS PLAT IS TRUE AND CORRECT.

BOUNDARY DESCRIPTION
 A PARCEL OF LAND LOCATED IN THE NORTHEAST QUARTER OF SECTION 13, AND THE SOUTHEAST QUARTER OF SECTION 12, TOWNSHIP 6 SOUTH, RANGE 2 WEST, SALT LAKE BASE AND MERIDIAN, SAID PARCEL BEING MORE PARTICULARLY DESCRIBED AS FOLLOWS:
 BEGINNING AT THE NORTHWESTERLY CORNER OF THE EAGLE POINT ROAD DEDICATION PLAT BOUNDARY AS RECORDED IN THE UTAH COUNTY RECORDER'S OFFICE AS MAP FILING NO. 14711, SAID POINT BEING NORTH 89°31'09" WEST ALONG THE SECTION LINE 1262.75 FEET AND NORTH 132.70 FEET FROM THE NORTHEAST CORNER OF SECTION 13, TOWNSHIP 6 SOUTH, RANGE 2 WEST, SALT LAKE BASE AND MERIDIAN, AND RUNNING THENCE ALONG THE BOUNDARY OF SAID EAGLE POINT ROAD DEDICATION PLAT THE FOLLOWING THREE (3) COURSES: 1) SOUTH 10°59'59" WEST 126.35 FEET; 2) SOUTHWESTERLY 171.32 FEET ALONG THE ARC OF A 205.00 FOOT RADIUS NON-TANGENT CURVE TO THE LEFT (CHORD BEARS SOUTH 27°38'33" WEST 166.38 FEET); 3) SOUTHWESTERLY 184.65 FEET ALONG THE ARC OF A 3738.05 FOOT RADIUS TANGENT CURVE TO THE RIGHT (CHORD BEARS SOUTH 05°06'53" WEST 184.63 FEET) TO A POINT ON THE NORTHERLY BOUNDARY OF EAGLE POINT TOWNHOMES PLAT "C" ON FILE WITH THE UTAH COUNTY RECORDER'S OFFICE AS ENTRY 169675; 2021, THENCE ALONG THE BOUNDARY OF SAID EAGLE POINT PHASE "C" NORTH 82°02'57" WEST 316.86 FEET; THENCE NORTH 09°21'25" EAST 492.90 FEET TO THE SOUTH RIGHT-OF-WAY OF EAGLE MOUNTAIN BOULEVARD; THENCE SOUTHEASTERLY ALONG SAID RIGHT-OF-WAY A DISTANCE OF 359.34 FEET ALONG THE ARC OF A 10046.50 FOOT RADIUS NON-TANGENT CURVE TO THE LEFT (CHORD BEARS SOUTH 77°58'34" EAST 359.32 FEET) TO THE POINT OF BEGINNING.
 CONTAINING 3.59 ACRES, MORE OR LESS.

ENT 7045612022 Map # 18369
 ANDREA ALLEN
 UTAH COUNTY RECORDER
 2022 Jun 14 12:48 pm FEE 244.00 BY CH
 RECORDED FOR EAGLE MOUNTAIN CITY

May 10, 2022
 DATE

[Signature]
 SURVEYOR
 (SEE SEAL BELOW)

OWNERS' DEDICATION
 WE, THE UNDERSIGNED OWNERS OF ALL THE REAL PROPERTY DEPICTED ON THIS PLAT AND DESCRIBED IN THE SURVEYOR'S CERTIFICATE ON THIS PLAT, HAVE CAUSED THE LAND DESCRIBED ON THIS PLAT TO BE DIVIDED INTO LOTS, STREETS, PARKS, OPEN SPACES, EASEMENTS, AND OTHER PUBLIC USES AS DESIGNATED ON THE PLAT AND NOW DO HEREBY DEDICATE UNDER THE PROVISIONS OF 10-95-607, UTAH CODE, WITHOUT CONDITION, RESTRICTION, OR RESERVATION TO EAGLE MOUNTAIN CITY, UTAH, ALL STREETS, WATER, SEWER, AND OTHER UTILITY EASEMENTS AND IMPROVEMENTS, OPEN SPACES SHOWN AS PUBLIC OPEN SPACES, PARKS AND ALL OTHER PLACES OF PUBLIC USE AND ENJOYMENT TO EAGLE MOUNTAIN CITY, UTAH TOGETHER WITH ALL IMPROVEMENTS REQUIRED BY THE DEVELOPMENT AGREEMENT BETWEEN THE UNDERSIGNED AND EAGLE MOUNTAIN CITY FOR THE BENEFIT OF THE CITY AND THE INHABITANTS THEREOF.

PURSUANT TO UTAH CODE 10-9A-604(D), THE OWNER HEREBY CONVEYS THE COMMON AREAS, AS INDICATED HEREON, TO THE DRN EAGLE POINT TOWNHOME OWNER'S ASSOCIATION, WITH A REGISTERED ADDRESS OF: 12351 SOUTH GATEWAY PARK PLACE D-100, DRAPER, UTAH 84042.

Grenobl EAGLE POINT, LLC
 PRINTED NAME OF OWNER
 A.J. Green
 AUTHORIZED SIGNATURE(S)
[Signature]
 Manager
 05.19.2022

PRINTED NAME OF OWNER
 AUTHORIZED SIGNATURE(S)

LLC ACKNOWLEDGEMENT
 STATE OF UTAH } S.S.
 COUNTY OF UTAH } S.S.
 ON THIS 17th DAY OF May, A.D. 2022, PERSONALLY APPEARED BEFORE ME
 A.J. Green, THE SIGNER OF THE FOREGOING INSTRUMENT, WHO DULY
 ACKNOWLEDGED TO ME THAT S(HE) IS A [MEMBER WITH MANAGEMENT AUTHORITY] [MANAGER] OF
 Grenobl Eagle Point, LLC, A UTAH LIMITED LIABILITY COMPANY, AND IS AUTHORIZED
 TO EXECUTE THE FOREGOING AGREEMENT IN ITS BEHALF AND THAT HE OR SHE EXECUTED IT IN SUCH
 CAPACITY.
[Signature]
 WITNESS MY HAND OFFICIAL SEAL.

I CERTIFY UNDER PENALTY OF PERJURY UNDER THE LAWS OF THE STATE OF UTAH THAT THE FOREGOING PARAGRAPH IS TRUE AND CORRECT.

NOTARY PUBLIC FULL NAME: Kristen Beattie
 COMMISSION NUMBER: 706467
 MY COMMISSION EXPIRES: 01/03/2023
 A NOTARY PUBLIC COMMISSIONED IN UTAH

ACCEPTANCE BY LEGISLATIVE BODY
 THE CITY COUNCIL OF EAGLE MOUNTAIN CITY, COUNTY OF UTAH, APPROVES THIS SUBDIVISION AND HEREBY ACCEPTS THE DEDICATION OF ALL STREETS, EASEMENTS, AND OTHER PARCELS OF LAND INTENDED FOR PUBLIC PURPOSES FOR THE PERPETUAL USE OF THE PUBLIC THIS 13 DAY OF June 2022.

[Signature]
 APPROVED BY MAYOR

[Signature]
 APPROVED BY CITY ATTORNEY

[Signature]
 APPROVED BY CITY ENGINEER

[Signature]
 APPROVED BY CITY RECORDER
 (SEE SEAL BELOW)

EAGLE POINT TOWNHOMES PLAT "D"
 A RESIDENTIAL SUBDIVISION

LOCATED IN THE NORTHEAST QUARTER OF SECTION 13 AND THE SOUTHEAST QUARTER OF SECTION 12, TOWNSHIP 6 SOUTH, RANGE 2 WEST, SALT LAKE BASE AND MERIDIAN
 SHEET 1 OF 2

RECORDING INFORMATION

SURVEYOR'S SEAL
 KAGAN M. DIXON
 No. 266052
 No. 9061091
 05/10/2022

NOTARY PUBLIC SEAL
 CITY ENGINEER
 CLERK-RECORDER SEAL
 EAGLE MOUNTAIN CITY
 EST. 1996
 STATE OF UTAH

DIRECT COMMUNICATIONS
 DIRECT COMMUNICATIONS CEDAR VALLEY, LLC CERTIFIED THAT IT WILL PROVIDE TELECOMMUNICATIONS SERVICES TO THIS SUBDIVISION UTILIZING THE TRENCHES PROVIDED BY THE DEVELOPER AS PER THE DIRECT COMMUNICATIONS CEDAR VALLEY P.S.C. UTAH NO. 1 TARIFF.

[Signature]
 DIRECT COMMUNICATIONS
 DATE: 5/23/2022

DOMINION ENERGY
 QUESTAR GAS COMPANY DBA DOMINION ENERGY UTAH HEREBY APPROVES THIS PLAT SOLELY FOR PURPOSE OF CONFIRMING THAT THE PLAT CONTAINS PUBLIC UTILITY EASEMENTS. DOMINION ENERGY UTAH MAY REQUIRE ADDITIONAL EASEMENTS IN ORDER TO SERVE THIS DEVELOPMENT. THIS APPROVAL DOES NOT CONSTITUTE ABROGATION OR WAIVER OF ANY OTHER EXISTING RIGHTS, OBLIGATIONS OR LIABILITIES INCLUDING PRESCRIPTIVE RIGHTS AND OTHER RIGHTS, OBLIGATIONS OR LIABILITIES PROVIDED BY LAW OR EQUITY. THIS APPROVAL DOES NOT CONSTITUTE ACCEPTANCE, APPROVAL OR ACKNOWLEDGMENT OF ANY TERMS CONTAINED IN THE PLAT, INCLUDING THOSE SET FORTH IN THE OWNERS DEDICATION AND THE NOTES, AND DOES NOT CONSTITUTE A GUARANTEE OF PARTICULAR TERMS OF NATURAL GAS SERVICE. FOR FURTHER INFORMATION PLEASE CONTACT DOMINION ENERGY UTAH'S RIGHT-OF-WAY DEPARTMENT AT 1-800-366-8532.

QUESTAR GAS COMPANY
 DBA DOMINION ENERGY UTAH
 APPROVED THIS 23 DAY OF May, 2022

BY: *[Signature]*
 TITLE: *[Signature]*

ROCKY MOUNTAIN POWER
 1. PURSUANT TO UTAH CODE ANN. § 54-3-27 THIS PLAT CONVEYS TO THE OWNER(S) OR OPERATORS OF UTILITY FACILITIES A PUBLIC UTILITY EASEMENT ALONG WITH ALL RIGHTS AND DUTIES DESCRIBED THEREIN.
 2. PURSUANT TO UTAH CODE ANN. § 17-27a-603(4)(c)(i) ROCKY MOUNTAIN POWER ACCEPTS DELIVERY OF THE PUE AS DESCRIBED IN THIS PLAT AND APPROVES THIS PLAT SOLELY FOR THE PURPOSE OF CONFIRMING THAT THE PLAT CONTAINS PUBLIC UTILITY EASEMENTS AND APPROXIMATES THE LOCATION OF THE PUBLIC UTILITY EASEMENT, BUT DOES NOT WARRANT THEIR PRECISE LOCATION. ROCKY MOUNTAIN POWER MAY REQUIRE OTHER EASEMENTS IN ORDER TO SERVE THIS DEVELOPMENT. THIS APPROVAL DOES NOT AFFECT ANY RIGHT THAT ROCKY MOUNTAIN POWER HAS UNDER
 (1) A RECORDED EASEMENT OR RIGHT OF WAY
 (2) THE LAW APPLICATION TO PRESCRIPTIVE RIGHTS
 (3) TITLE 54, CHAPTER 80, DAMAGE TO UNDERGROUND UTILITY FACILITIES, OR
 (4) ANY OTHER PROVISION OF LAW

[Signature]
 ROCKY MOUNTAIN POWER
 DATE: 5/23/22

TABULATIONS

TOTAL AREA	3.59 ACRES
TOTAL ACREAGE IN LOTS	1.08 ACRES
TOTAL COMMON AREA	1.58 ACRES
TOTAL IMPROVED COMMON AREA	1.58 ACRES
PUBLIC ROW DEDICATION	0 ACRES
PRIVATE ROW	0.74 ACRES
DRIVEWAYS/PARKING	0.35 ACRES
TOTAL NUMBER OF LOTS	58
AVERAGE LOT FOOTPRINT SIZE	811 SQ FT
LARGEST LOT FOOTPRINT SIZE	820 SQ FT
SMALLEST LOT FOOTPRINT SIZE	792 SQ FT
OVERALL DENSITY	16.16 UNITS/ACRE



18369
 Sheet 1 of 2

SEC 12, 13 T 6 S 1 E 2 W S 10 M TU 38 DR

EAGLE POINT TOWNHOMES PLAT "D"

A RESIDENTIAL SUBDIVISION

LOCATED IN THE NORTHEAST QUARTER OF SECTION 13 AND THE SOUTHEAST QUARTER OF SECTION 12,
TOWNSHIP 6 SOUTH, RANGE 2 WEST, SALT LAKE BASE AND MERIDIAN
EAGLE MOUNTAIN CITY, UTAH COUNTY, UTAH
SHEET 2 OF 2

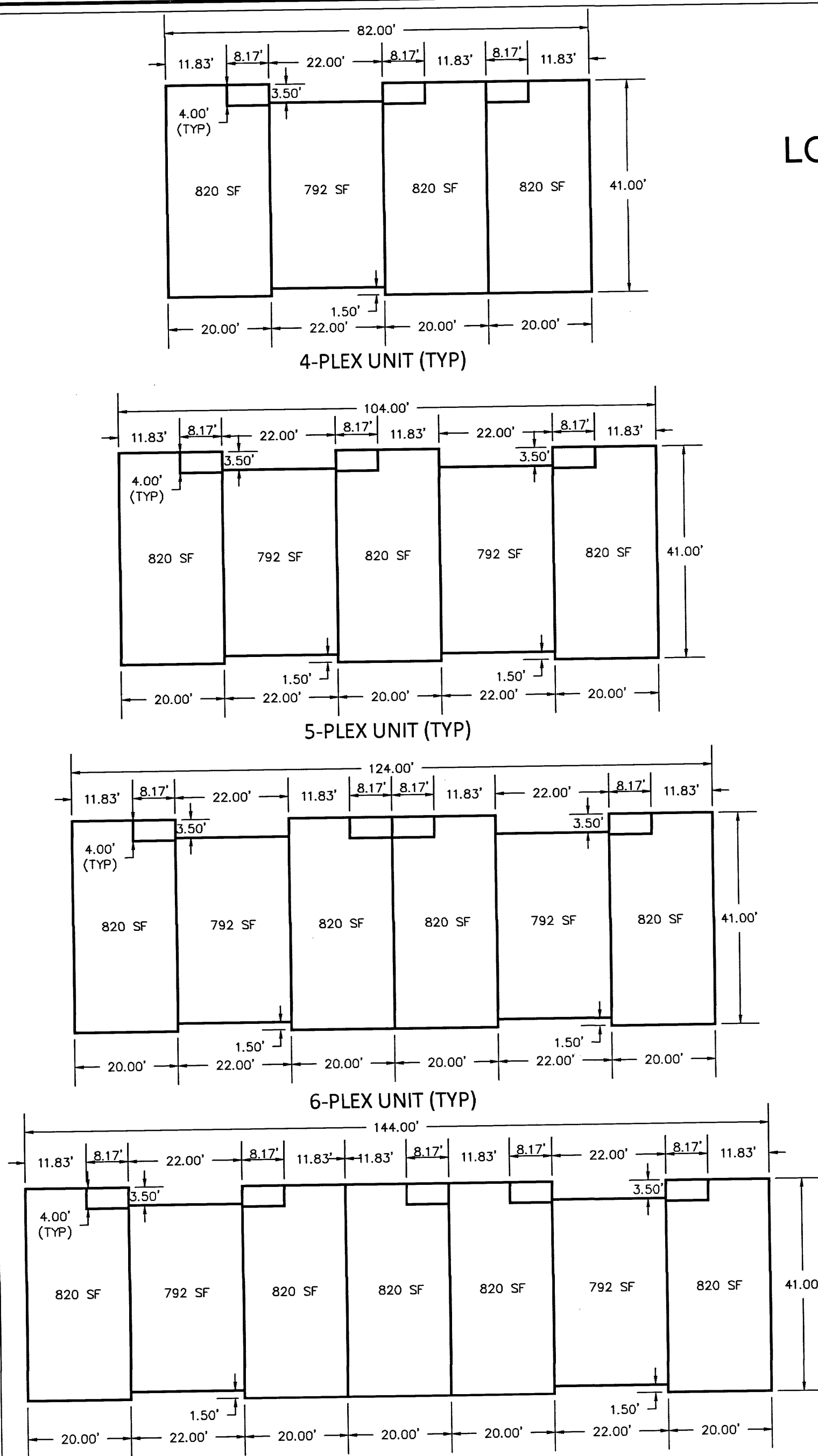

CURVE #	LENGTH	RADIUS	DELTA	CHORD BEARING	CHORD DISTANCE
C1	152.42'	100.00'	87°19'58"	S34°18'34"E	138.09'
C2	52.45'	100.00'	30°03'06"	N62°57'00"W	51.85'
C3	65.55'	300.00'	12°31'06"	S15°36'59"W	65.42'
C4	69.48'	200.00'	19°54'11"	S00°35'40"E	69.13'
C5	52.27'	200.00'	14°58'28"	N03°03'31"W	52.12'
C6	23.09'	500.00'	2°38'46"	N05°45'06"E	23.09'
C7	43.68'	300.00'	8°20'35"	S09°01'17"W	43.64'
C8	104.75'	114.00'	52°38'47"	S16°57'59"E	101.10'
C9	28.75'	25.50'	64°36'03"	N10°59'21"W	27.25'
C10	65.51'	314.00'	11°57'15"	S15°20'03"W	65.39'
C11	74.34'	214.00'	19°54'11"	S00°35'40"E	73.97'
C12	48.61'	186.00'	14°58'28"	N03°03'31"W	48.47'
C13	22.23'	486.00'	2°37'15"	N05°44'20"E	22.23'
C14	131.09'	86.00'	87°19'58"	S34°18'34"E	118.76'
C15	59.79'	114.00'	30°03'06"	N62°57'00"W	59.11'
C16	38.49'	25.50'	86°28'40"	S38°48'37"E	34.94'
C17	55.93'	214.00'	14°58'28"	N03°03'31"W	55.77'
C18	64.61'	186.00'	19°54'11"	S00°35'40"E	64.29'
C19	46.36'	286.00'	9°17'13"	S14°00'02"W	46.31'
C20	37.68'	25.50'	84°39'12"	S60°58'15"W	34.34'
C21	40.58'	25.50'	91°10'08"	N32°23'29"W	36.43'
C22	45.72'	314.00'	8°20'35"	S09°01'17"W	45.68'
C23	41.44'	25.50'	93°06'03"	N51°24'01"E	37.02'
C24	38.68'	25.50'	86°53'57"	S38°35'59"E	35.07'
C25	41.64'	286.00'	8°20'35"	S09°01'17"W	41.61'
C26	52.91'	25.50'	118°52'58"	S72°38'04"W	43.92'
C27	116.01'	100.00'	66°27'58"	S23°52'34"E	109.61'
C28	36.42'	100.00'	20°52'01"	S67°32'33"E	36.22'
C29	7.08'	486.00'	0°50'06"	N06°37'55"E	7.08'

CURVE #	LENGTH	RADIUS	DELTA	CHORD BEARING	CHORD DISTANCE
C30	15.15'	486.00'	1°47'10"	N05°19'17"E	15.15'
C31	36.63'	286.00'	7°20'16"	S13°01'34"W	36.60'
C32	9.73'	286.00'	1°56'58"	S17°40'10"W	9.73'
C33	15.76'	314.00'	2°52'32"	S06°17'16"W	15.76'
C34	29.96'	314.00'	5°28'03"	S10°27'33"W	29.95'
C35	1.23'	25.50'	2°46'28"	S14°34'48"W	1.23'
C36	51.68'	25.50'	116°06'30"	S74°01'17"W	43.28'
C37	4.57'	114.00'	2°17'43"	N78°49'42"W	4.57'
C38	14.24'	114.00'	7°09'25"	N72°06'08"W	14.23'
C39	40.99'	114.00'	20°35'59"	N58°13'27"W	40.77'
C40	121.13'	86.00'	80°41'53"	S30°59'32"E	111.36'
C41	9.96'	86.00'	6°38'05"	S74°39'31"E	9.95'
C42	2.53'	114.00'	1°16'25"	S77°20'21"E	2.53'
C43	123.30'	205.00'	34°27'44"	S20°55'55"W	121.45'
C44	14.01'	205.00'	3°54'57"	S40°07'16"W	14.01'
C45	14.01'	205.00'	3°54'57"	S44°02'13"W	14.01'
C46	20.00'	205.00'	5°35'21"	S48°47'22"W	19.99'
C47	17.54'	10046.50'	0°06'00"	S77°00'05"E	17.54'
C48	14.03'	10046.50'	0°04'48"	S77°05'29"E	14.03'
C49	14.03'	10046.50'	0°04'48"	S77°10'17"E	14.03'
C50	313.75'	10046.50'	1°47'22"	S78°06'22"E	313.74'

Line #	Length	Direction
L1	5.09	S12° 01' 26.54"W
L2	4.69	N22° 24' 02.67"E

- NOTES:
- ALL OPEN SPACE AND TRAIL IMPROVEMENTS LOCATED HEREIN ARE TO BE INSTALLED BY THE OWNER UNLESS SPECIFIED OTHERWISE ON EACH IMPROVEMENT. THESE IMPROVEMENTS SHALL BE MAINTAINED BY THE HOMEOWNER'S ASSOCIATION.
 - ALL LIMITED COMMON AND COMMON AREAS AS DESIGNATED ON THIS PLAT ALSO SHALL SERVE AS PUBLIC UTILITY AND DRAINAGE EASEMENTS.
 - FOR ALLOWED USES AND RESTRICTIONS FOR LIMITED COMMON AND COMMON AREAS, REFER TO THE HOMEOWNER'S ASSOCIATION COVENANTS, CONDITIONS, & RESTRICTIONS DOCUMENT.

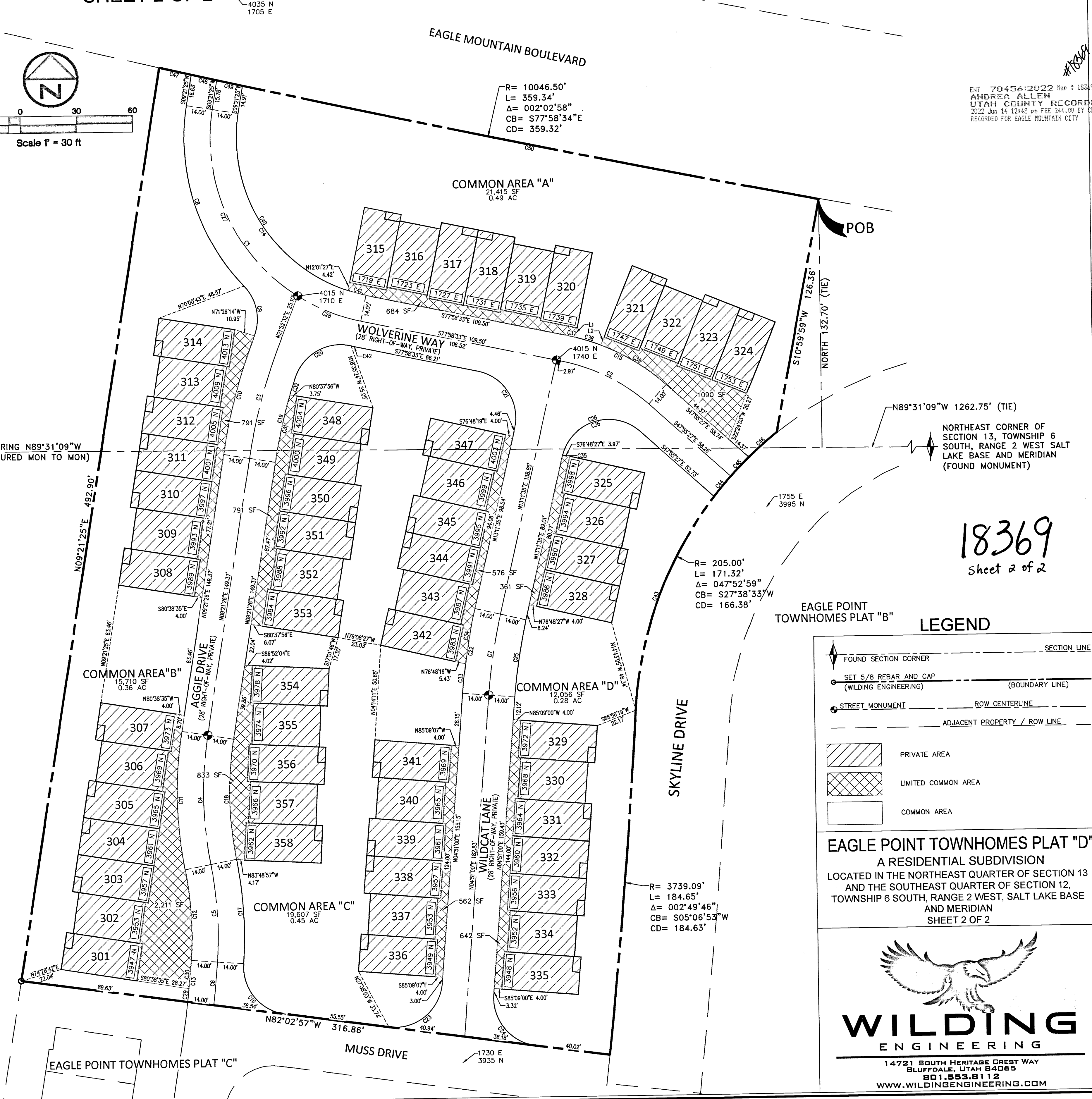
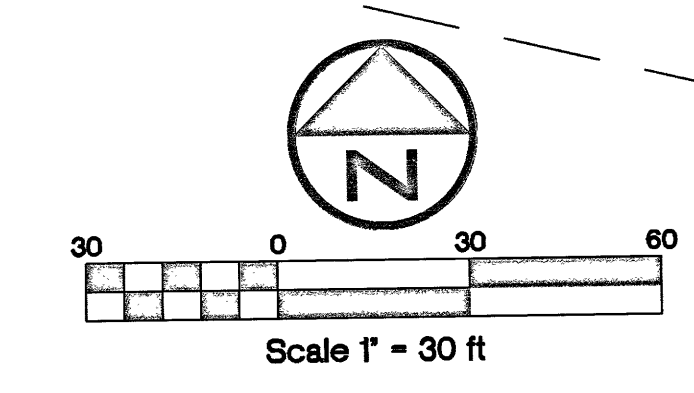

LEGEND

- FOUND SECTION CORNER
- SET 5/8 REBAR AND CAP (WILDING ENGINEERING) (BOUNDARY LINE)
- STREET MONUMENT (ROW CENTERLINE)
- ADJACENT PROPERTY / ROW LINE
- PRIVATE AREA
- LIMITED COMMON AREA
- COMMON AREA

EAGLE POINT TOWNHOMES PLAT "D"
A RESIDENTIAL SUBDIVISION
LOCATED IN THE NORTHEAST QUARTER OF SECTION 13
AND THE SOUTHEAST QUARTER OF SECTION 12,
TOWNSHIP 6 SOUTH, RANGE 2 WEST, SALT LAKE BASE
AND MERIDIAN
SHEET 2 OF 2

WILDING ENGINEERING
14721 SOUTH HERITAGE CREST WAY
BLUFFDALE, UTAH 84065
801.553.8112
WWW.WILDINGENGINEERING.COM

70456:2022 Map # 18369
ANDREA ALLEN
UTAH COUNTY RECORDER
2022 Jun 14 12:48 pm FEE 244.00 BY 18369
RECORDED FOR EAGLE MOUNTAIN CITY

18369
Sheet 2 of 2