

# BRIDGEPORT SUBDIVISION

## A AMENDMENT OF LOT 1, WEST JORDAN MIDDLE SCHOOL NO. 2 SUBDIVISION

LOCATED IN THE SOUTHWEST QUARTER OF SECTION 34, TOWNSHIP 2 SOUTH, RANGE 2 WEST, SALT LAKE BASE AND MERIDIAN, LOCATED IN WEST JORDAN CITY, COUNTY OF SALT LAKE, STATE OF UTAH  
CONTAINS: 790,127 SQUARE FEET, OR 18.138 ACRES IN 57 LOTS AND 1 PARCEL

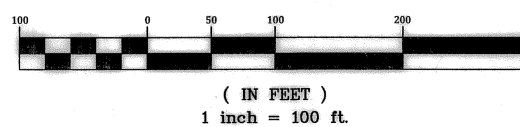
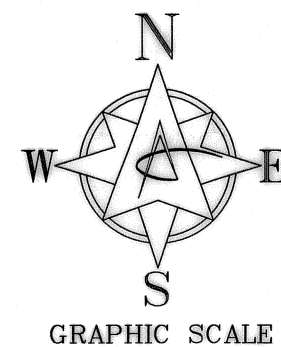

**LEGEND:**

- SECTION CORNER (FOUND SALT LAKE COUNTY MONUMENT)
- BOUNDARY CORNER
- SECTION LINE
- RIGHT-OF-WAY LINE
- CENTERLINE
- EXISTING LOT LINE
- EXISTING SUBDIVISION ROW LINE

**SURVEYOR'S CERTIFICATE**

I, DENNIS K. WITHERS, DO HEREBY CERTIFY THAT I AM A PROFESSIONAL LAND SURVEYOR LICENSED TO PRACTICE IN THE STATE OF UTAH, AND THAT I HAVE MADE A SURVEY OF THE PARCEL OF LAND SHOWN AND DESCRIBED ON THIS MAP. I ALSO CERTIFY THAT BY AUTHORITY OF THE OWNERS I HAVE SUBDIVIDED SAID PARCEL INTO LOTS, AND STREETS, TO BE HEREAFTER KNOWN AS:

**BRIDGEPORT SUBDIVISION**

THE SURVEY WAS PERFORMED IN ACCORDANCE WITH GENERALLY ACCEPTED SURVEYING PRACTICES, AND WAS MARKED ON THE GROUND AS SHOWN ON THIS PLAT.

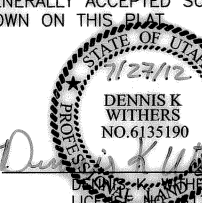

DATE: July 27, 2012

**LEGAL DESCRIPTION PER TITLE REPORT:**

A PARCEL OF LAND SITUATE IN THE SOUTHWEST QUARTER OF SECTION 34, TOWNSHIP 2 SOUTH, RANGE 2 WEST, SALT LAKE BASE AND MERIDIAN, SAID PARCEL BEING A PORTION OF LOT 1, WEST JORDAN MIDDLE SCHOOL SUBDIVISION, ACCORDING TO THE OFFICIAL PLAT THEREOF RECORDED MARCH 21, 2006 AS ENTRY NO. 9667962, IN BOOK 2006P OF PLATS, AT PAGE 69, OF OFFICIAL RECORDS, BEING MORE PARTICULARLY DESCRIBED AS FOLLOWS:

BEGINNING AT THE SOUTH QUARTER CORNER OF SECTION 34, TOWNSHIP 2 SOUTH, RANGE 2 WEST, SALT LAKE BASE AND MERIDIAN AND RUNNING THENCE NORTH 89°52'00" WEST 1416.11 FEET (1416.10') ALONG THE SOUTH LINE OF THE SOUTHWEST QUARTER OF SAID SECTION 34 TO A POINT WHICH LIES ON THE EASTERLY RIGHT-OF-WAY LINE OF SR-111; THENCE NORTH 08°02'35" EAST A DISTANCE OF 1539.92 FEET (1539.93') ALONG SAID EASTERLY RIGHT-OF-WAY LINE; THENCE SOUTH 89°59'26" EAST A DISTANCE OF 209.82 FEET (209.79'); THENCE SOUTH 00°00'34" WEST A DISTANCE OF 150.00 FEET; THENCE NORTH 89°59'26" WEST A DISTANCE OF 8.02 FEET; THENCE SOUTH 0°46'52" EAST A DISTANCE OF 114.01 FEET; THENCE NORTH 89°59'26" WEST A DISTANCE OF 4.56 FEET (4.55'); THENCE SOUTH 03°39'43" WEST A DISTANCE OF 714.43 FEET; THENCE NORTH 89°24'05" EAST A DISTANCE OF 139.90 FEET; THENCE SOUTH 00°46'52" EAST A DISTANCE OF 79.95 FEET, TO A POINT ON A TANGENT CURVE TO THE RIGHT, HAVING A RADIUS OF 15.00 FEET AND A CENTRAL ANGLE OF 90°11'57"; THENCE ALONG THE ARC OF SAID CURVE A DISTANCE OF 23.61 FEET, SAID ARC SUBTENDED BY A CHORD BEARING SOUTH 44°18'37" WEST, A DISTANCE OF 21.25 FEET; THENCE SOUTH 00°35'55" EAST A DISTANCE OF 50.00 FEET; THENCE SOUTH 89°24'05" WEST A DISTANCE OF 3.79 FEET; THENCE SOUTH 00°46'52" EAST A DISTANCE OF 93.64 FEET; THENCE NORTH 89°24'05" EAST A DISTANCE OF 269.00 FEET; THENCE SOUTH 00°46'52" EAST A DISTANCE OF 6.57 FEET; THENCE NORTH 89°13'08" EAST A DISTANCE OF 550.00 FEET; THENCE NORTH 00°46'52" WEST A DISTANCE OF 32.14 FEET; THENCE NORTH 89°13'08" EAST A DISTANCE OF 100.00 FEET; THENCE SOUTH 00°46'52" EAST A DISTANCE OF 350.98 FEET TO THE POINT OF BEGINNING.

CONTAINS: 790,127 SQUARE FEET, OR 18.138 ACRES IN 57 LOTS AND 1 PARCEL

\* NOTE: COURSES OR DISTANCE SHOWN IN PARENTHESES ARE RECORD COURSES.

**OWNERS DEDICATION**

KNOW ALL BY THESE PRESENTS THAT THE UNDERSIGNED OWNER(S) OF THE DESCRIBED TRACT OF LAND ABOVE, HAVING CAUSED THE SAME TO BE SUBDIVIDED INTO LOTS AND STREETS TO HEREAFTER BE KNOWN AS:

**BRIDGEPORT SUBDIVISION**

DOES HEREBY DEDICATE FOR PERPETUAL USE OF THE PUBLIC ALL PARCELS OF LAND SHOWN ON THIS PLAT AS INTENDED FOR PUBLIC USE, AND WARRANT, DEFEND, AND SAVE THE CITY HARMLESS AGAINST ANY EASEMENTS OR OTHER ENCUMBRANCES ON THE DEDICATED STREETS WHICH WILL INTERFERE WITH THE CITY'S USE, OPERATION, AND MAINTENANCE OF THE STREETS AND DO FURTHER DEDICATE THE EASEMENTS AS SHOWN FOR THE USE BY ALL SUPPLIERS OF UTILITY OR OTHER NECESSARY SERVICES.

IN WITNESS WHEREOF, WE HAVE HERETO SET OUR

HANDS THIS 27 DAY OF August, A.D. 2012

*[Signature]*  
I, Dennis K. Withers, Surveyor, DO HEREBY CERTIFY THAT I AM A PROFESSIONAL LAND SURVEYOR LICENSED TO PRACTICE IN THE STATE OF UTAH, AND THAT I HAVE MADE A SURVEY OF THE PARCEL OF LAND SHOWN AND DESCRIBED ON THIS MAP. I ALSO CERTIFY THAT BY AUTHORITY OF THE OWNERS I HAVE SUBDIVIDED SAID PARCEL INTO LOTS, AND STREETS, TO BE HEREAFTER KNOWN AS:

**LIMITED LIABILITY ACKNOWLEDGEMENT**

STATE OF UTAH }  
COUNTY OF SALT LAKE } s.s.

ON THE 27 DAY OF August, A.D. 2012, PERSONALLY APPEARED BEFORE ME *[Signature]* WHO BEING BY ME DULY SWORN DID SAY THAT HE/SHE/they IS/ARE THE

Ivory Development, LLC OF Utah COUNTY, Salt Lake COUNTY, UTAH. BY THE AUTHORITY OF ITS MEMBERS OR ITS ARTICLES OF ORGANIZATION, AND HE/SHE/they ACKNOWLEDGED TO ME THAT SAID LIMITED LIABILITY COMPANY EXECUTED THE SAME.

**LIMITED LIABILITY ACKNOWLEDGEMENT**

STATE OF UTAH }  
COUNTY OF SALT LAKE } s.s.

ON THE 27 DAY OF August, A.D. 2012, PERSONALLY APPEARED BEFORE ME *[Signature]* WHO BEING BY ME DULY SWORN DID SAY THAT HE/SHE/they IS/ARE THE

Ivory Development, LLC OF Utah COUNTY, Salt Lake COUNTY, UTAH. BY THE AUTHORITY OF ITS MEMBERS OR ITS ARTICLES OF ORGANIZATION, AND HE/SHE/they ACKNOWLEDGED TO ME THAT SAID LIMITED LIABILITY COMPANY EXECUTED THE SAME.

**LIMITED LIABILITY ACKNOWLEDGEMENT**

STATE OF UTAH }  
COUNTY OF SALT LAKE } s.s.

ON THE 27 DAY OF August, A.D. 2012, PERSONALLY APPEARED BEFORE ME *[Signature]* WHO BEING BY ME DULY SWORN DID SAY THAT HE/SHE/they IS/ARE THE

Ivory Development, LLC OF Utah COUNTY, Salt Lake COUNTY, UTAH. BY THE AUTHORITY OF ITS MEMBERS OR ITS ARTICLES OF ORGANIZATION, AND HE/SHE/they ACKNOWLEDGED TO ME THAT SAID LIMITED LIABILITY COMPANY EXECUTED THE SAME.

NOTARY PUBLIC  
MY COMMISSION EXPIRES: 5/1/2012 COUNTY, Salt Lake

**PARCEL 'A' LEGAL DESCRIPTION:**

A PARCEL OF LAND SITUATE IN THE SOUTHWEST QUARTER OF SECTION 34, TOWNSHIP 2 SOUTH, RANGE 2 WEST, SALT LAKE BASE & MERIDIAN, SAID PARCEL BEING A PORTION OF LOT 1, WEST JORDAN MIDDLE SCHOOL SUBDIVISION, ACCORDING TO THE OFFICIAL PLAT THEREOF RECORDED MARCH 21, 2006 AS ENTRY NO. 9667962, IN BOOK 2006P OF PLATS, AT PAGE 69, OF OFFICIAL RECORDS, SAID PARCEL BEING MORE PARTICULARLY DESCRIBED AS FOLLOWS:

BEGINNING AT A POINT NORTH 89° 52' 00" WEST, ALONG THE SOUTH LINE OF THE SOUTHWEST QUARTER, A DISTANCE OF 1107.29 FEET, FROM THE FOUND SALT LAKE COUNTY MONUMENT MARKING THE SOUTH QUARTER CORNER OF SAID SECTION 34; AND RUNNING THENCE NORTH 89° 52' 00" WEST, ALONG SAID QUARTER SECTION LINE, A DISTANCE OF 308.82 FEET, TO THE EASTERLY LINE OF U-111; THENCE NORTH 8° 02' 35" EAST, ALONG SAID EASTERLY LINE, A DISTANCE OF 308.75 FEET; THENCE NORTH 89° 24' 05" EAST, A DISTANCE OF 261.41 FEET; THENCE SOUTH 0° 46' 52" EAST, A DISTANCE OF 309.19 FEET, TO THE POINT OF BEGINNING. CONTAINS: 87,634 SQ.FT., OR 2.012 ACRES

**LIMITED LIABILITY ACKNOWLEDGEMENT**

STATE OF UTAH }  
COUNTY OF SALT LAKE } s.s.

ON THE 27 DAY OF August, A.D. 2012, PERSONALLY APPEARED BEFORE ME *[Signature]* WHO BEING BY ME DULY SWORN DID SAY THAT HE/SHE/they IS/ARE THE

Ivory Development OF Utah COUNTY, Salt Lake COUNTY, UTAH. BY THE AUTHORITY OF ITS MEMBERS OR ITS ARTICLES OF ORGANIZATION, AND HE/SHE/they ACKNOWLEDGED TO ME THAT SAID LIMITED LIABILITY COMPANY EXECUTED THE SAME.

NOTARY PUBLIC  
MY COMMISSION EXPIRES: 5/1/2012 COUNTY, Salt Lake

**GENERAL NOTES:**

1. THE BASIS OF BEARING FOR THIS PLAT IS NORTH 89°52'00" WEST ALONG THE SOUTH LINE OF THE SOUTHWEST QUARTER OF SECTION 34, TOWNSHIP 2 SOUTH, RANGE 2 WEST, SALT LAKE BASE & MERIDIAN AS SHOWN HEREON.
2. COURSES AND DISTANCES SHOWN ON THIS MAP ARE MEASURED DIMENSIONS TAKEN FROM ACTUAL FIELD MEASUREMENTS, UNLESS FOLLOWED WITH AN "(R)" INDICATING A RECORD COURSE OR DISTANCE. RECORD INFORMATION IS TAKEN FROM MAPS, PLATS, DEEDS OF RECORD, OR OTHER SOURCES OF RECORD INFORMATION.
3. THIS MAP WAS PREPARED AT THE REQUEST OF IVORY DEVELOPMENT LLC FOR THE PURPOSE OF SUBDIVIDING THE HEREON DESCRIBED PARCEL OF LAND INTO LOTS AND STREETS.
4. THERE ARE NO BUILDINGS CURRENTLY LOCATED ON THE HEREON DESCRIBED PARCEL OF LAND.
5. THE MAP WAS PREPARED BASED UPON COMMITMENT FOR TITLE INSURANCE PREPARED BY COTTONWOOD TITLE INSURANCE AGENCY INF FILE NO. 51890-TF, 1ST AMENDED WITH AN EFFECTIVE DATE OF MARCH 20, 2012, AT 7:30 A.M. ONLY EASEMENT REFERENCED IN THE ABOVE COMMITMENT ARE ADDRESSED BY THIS MAP.
6. THE CURRENT OWNER OF RECORD IS LAND SOLUTIONS LC, A UTAH LIMITED LIABILITY COMPANY ACCORDING TO THE ABOVE REFERENCED COMMITMENT.
7. THE SUBJECT PROPERTY IS LOCATED WITHIN FLOOD ZONE X PER FEMA MAP PANEL NO. 49035C0410G
8. THERE IS A 10.0' PUBLIC UTILITY EASEMENT ALONG THE OUTSIDE OF ALL PUBLIC ROADWAYS.
9. THERE IS A 10.0 FOOT PUBLIC UTILITY & DRAINAGE EASEMENT ALONG THE FRONT AND BACK OF ALL LOTS AND A 7.5 FOOT PUBLIC UTILITY AND DRAINAGE EASEMENT ALONG ALL SIDE LOT LINES LINE.
10. SETBACK LINES ARE BASED UPON UNDERLYING CITY ZONING REQUIREMENTS.

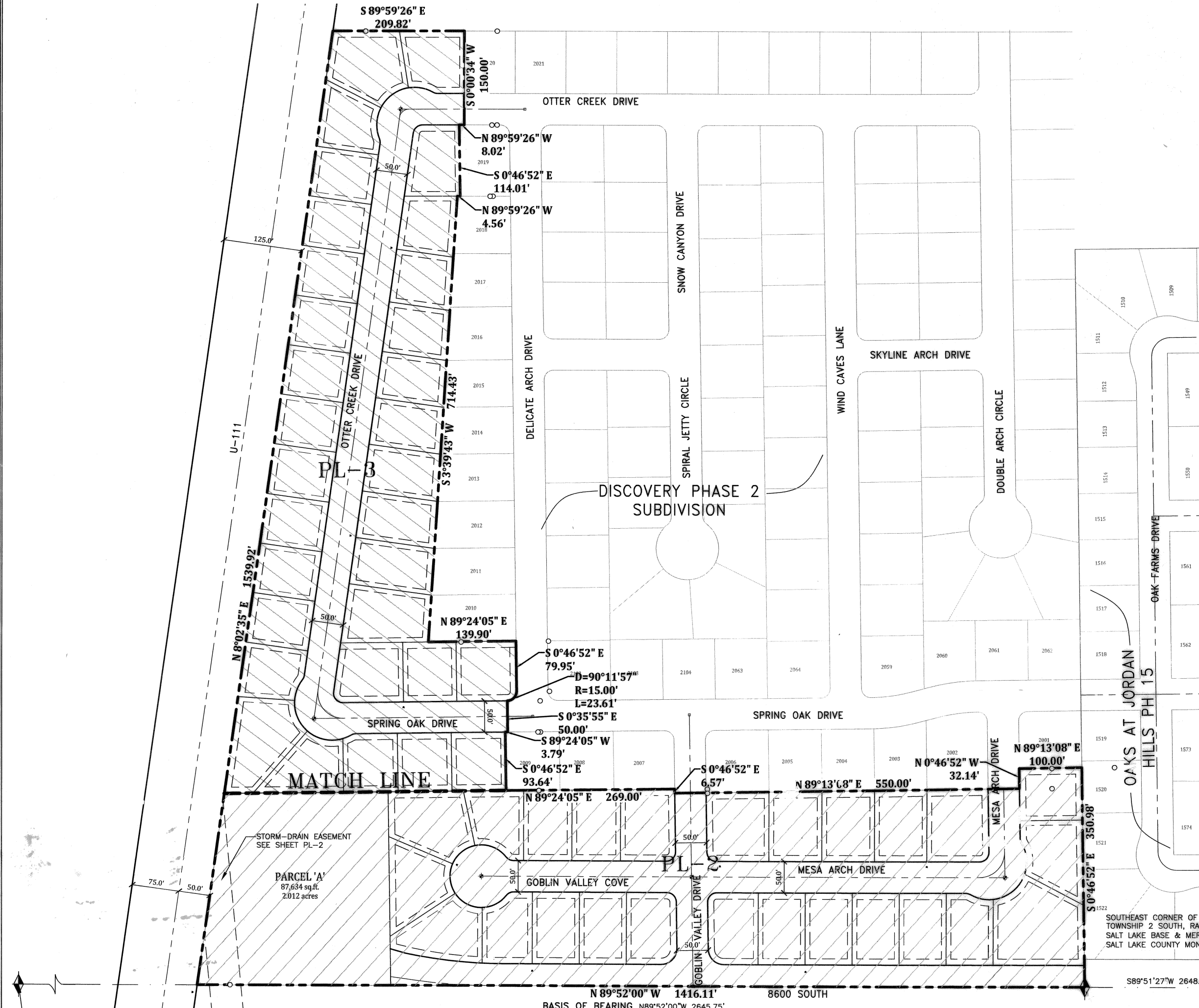

SOUTHWEST CORNER OF SECTION 34, TOWNSHIP 2 SOUTH, RANGE 2 WEST, SALT LAKE BASE & MERIDIAN, (FOUND SALT LAKE COUNTY MONUMENT)

POINT OF BEGINNING  
SOUTH QUARTER CORNER OF SECTION 34, TOWNSHIP 2 SOUTH, RANGE 2 WEST, SALT LAKE BASE & MERIDIAN, (FOUND SALT LAKE COUNTY MONUMENT)

REVISIONS				
No.	DATE	BY	REVISION	
0	2/05/2011	DKW	RELEASE TO CLIENT	
1	4/29/2011	DKW	ADDRESS CITY COMMENT	
2	2/24/2012	DKW	REVISE PLAT BOUNDARY & 8200 SOUTH	
3	3/15/2012	DKW	CHANGE SUBDIVISION NAME & ADDRESS CITY COMMENTS	
4	4/20/2012	DKW	CHANGE ACKNOWLEDGEMENTS & OWNER INFORMATION	
5	6/01/12	DKW	ADDRESS CITY COMMENTS AND MAKE ADJUSTMENT TO LOTS	

**CITY PLANNING COMMISSION**  
APPROVED THIS 21 DAY OF August, A.D. 2012, BY THE WEST JORDAN CITY PLANNING COMMISSION

*[Signature]*  
PRINTED NAME OF COMMISSION CHAIR

**BOARD OF HEALTH**  
APPROVED THIS 1 DAY OF August, A.D. 2012.

*[Signature]*  
APPROVED BY

**CITY ATTORNEY**  
APPROVED AS TO FORM THIS 17<sup>th</sup> DAY OF September, A.D. 2012.

*[Signature]*  
PRINTED NAME OF CITY ATTORNEY

**CITY ENGINEER**  
I HEREBY CERTIFY THAT I HAVE HAD THIS PLAT EXAMINED BY THIS OFFICE AND IT IS CORRECT AND IN ACCORDANCE WITH INFORMATION ON FILE AND IS HEREBY APPROVED.

*[Signature]* 16 Aug 2012  
PRINTED NAME OF CITY ENGINEER DATE

**CITY COUNCIL**  
PRESENTED TO WEST JORDAN CITY THIS 16 DAY OF September, A.D. 2012.

*[Signature]*  
PRINTED NAME OF MAYOR

**COMCAST**  
APPROVED AS TO FORM THIS 1 DAY OF Aug, A.D. 2012.

*[Signature]*  
COMCAST

**CENTURYLINK**  
APPROVED AS TO FORM THIS 31 DAY OF July, A.D. 2012.

*[Signature]*  
CENTURYLINK

**QUESTAR**  
APPROVED AS TO FORM THIS 1<sup>ST</sup> DAY OF August, A.D. 2012.

*[Signature]*  
QUESTAR

**SALT LAKE COUNTY RECORDER**  
RECORDED IN 1147318 RECORD NO.  
STATE OF UTAH, COUNTY OF SALT LAKE, RECORDED AND FILED AT THE REQUEST OF: IVORY DEVELOPMENT  
DATE 9/16/12 TIME 2:50 BOOK 2006P PAGE 140  
FEES \$ 148.00  
*[Signature]*  
PRINTED NAME OF COUNTY RECORDER

BRIDGEPORT SUBDIVISION  
A AMENDMENT OF LOT 1, WEST JORDAN MIDDLE SCHOOL NO. 2 SUBDIVISION  
LOCATED IN THE SOUTHWEST QUARTER OF SECTION 34, TOWNSHIP 2 SOUTH, RANGE 2 WEST, SALT LAKE BASE AND MERIDIAN, LOCATED IN WEST JORDAN CITY, COUNTY OF SALT LAKE, STATE OF UTAH  
CONTAINS: 790,127 SQUARE FEET, OR 18.138 ACRES IN 57 LOTS AND 1 PARCEL.  
SALT LAKE COUNTY, UTAH  
Ward Engineering Group  
Planning & Engineering & Surveying  
231 West 800 South Suite A  
Salt Lake City, Utah 84101  
Phone: (801)487-8040 Fax: (801)487-8668

Curve #	Length	Radius	Delta	Bearing	Chord
C1	52.05	60.00	49°42'22"	N5°51'16"W	50.44
C2	7.83	15.00	29°55'35"	N15°44'40"W	7.75
C3	67.73	59.82	64°51'57"	N51°19'30"E	64.17
C7	7.83	15.00	29°55'35"	S74°54'12"E	7.75
C8	38.12	60.34	36°11'43"	S78°08'40"E	37.49
C9	38.87	25.00	89°05'08"	N45°19'26"W	35.07
C10	23.80	15.00	90°54'52"	N44°40'34"E	21.38
C12	39.67	25.00	90°54'52"	S44°40'34"W	35.64
C16	23.32	15.00	89°05'08"	S45°19'26"E	21.04
C17	35.64	758.50	2°41'32"	N88°31'14"W	35.64
C18	43.80	50.00	50°11'25"	N63°12'30"E	42.41
C19	23.61	15.00	90°11'56"	S44°40'34"W	21.25
C20	13.62	15.00	52°01'12"	N63°51'24"W	13.16
C21	122.95	758.50	9°17'15"	N82°31'50"W	122.82
C25	50.94	50.00	58°22'23"	S63°30'36"E	48.77
C26	49.27	50.00	56°27'46"	S5°05'32"E	47.30
C27	47.94	50.00	54°56'22"	S50°36'32"W	46.13
C28	13.62	15.00	52°01'12"	N63°51'24"W	13.16
C29	55.92	50.00	64°04'30"	N69°53'02"W	53.05
C30	23.80	15.00	90°54'52"	S44°40'34"W	21.38
C31	23.32	15.00	89°05'08"	N45°19'26"W	21.04
C32	23.80	15.00	90°54'52"	S44°40'34"W	21.38
C33	14.56	60.00	13°54'02"	N66°16'17"E	14.52
C34	7.88	15.00	30°04'49"	N74°21'40"E	7.78
C37	60.51	60.00	57°47'00"	S77°53'12"E	57.98
C41	55.28	58.96	53°42'53"	S22°38'15"E	53.28
C42	7.83	15.00	29°55'35"	S23°00'23"W	7.75
C43	35.84	61.75	33°14'59"	S20°50'41"W	35.33
C44	51.32	60.00	49°00'35"	S23°37'17"W	49.77
C45	7.83	15.00	29°55'35"	S6°55'13"E	7.75
C46	56.25	60.00	53°42'53"	S33°59'01"W	54.21
C47	7.79	15.00	29°46'02"	N75°06'25"W	7.71
C48	40.77	60.00	38°56'08"	N79°41'28"W	39.99
C49	21.46	15.00	81°57'59"	N49°01'34"E	19.68
C50	25.82	15.00	98°38'30"	N41°16'40"W	22.75
C51	23.61	15.00	90°10'56"	S44°18'07"W	21.25
C52	114.59	800.00	8°12'26"	S85°45'47"E	114.49
C53	63.47	40.00	90°54'52"	N44°40'34"E	57.02
C54	68.86	40.00	98°38'30"	S41°16'40"W	60.67
C55	21.46	15.00	81°57'59"	S49°01'34"W	19.68

Line #	Length	Direction
L1	8.02	N89°59'26"W
L2	4.56	N89°59'26"W
L3	50.00	S0°35'55"E
L4	3.79	S89°24'05"W
L5	6.57	S0°46'52"E
L6	32.14	N0°46'52"W
L7	40.22	S81°39'34"E
L8	25.85	N74°01'53"W
L9	19.94	N0°46'52"W
L10	40.64	S89°52'00"E
L11	40.64	N0°46'52"W
L12	46.54	S89°24'05"W
L13	46.54	N80°23'35"E
L14	13.03	N89°59'26"W
L15	13.03	N80°23'35"E

# BRIDGEPORT SUBDIVISION

## A AMENDMENT OF LOT 1, WEST JORDAN MIDDLE SCHOOL NO. 2 SUBDIVISION

LOCATED IN THE SOUTHWEST QUARTER OF SECTION 34, TOWNSHIP 2 SOUTH, RANGE 2 WEST, SALT LAKE BASE AND MERIDIAN, LOCATED IN WEST JORDAN CITY, COUNTY OF SALT LAKE, STATE OF UTAH  
CONTAINS: 790,127 SQUARE FEET, OR 18.139 ACRES IN 57 LOTS AND 1 PARCEL

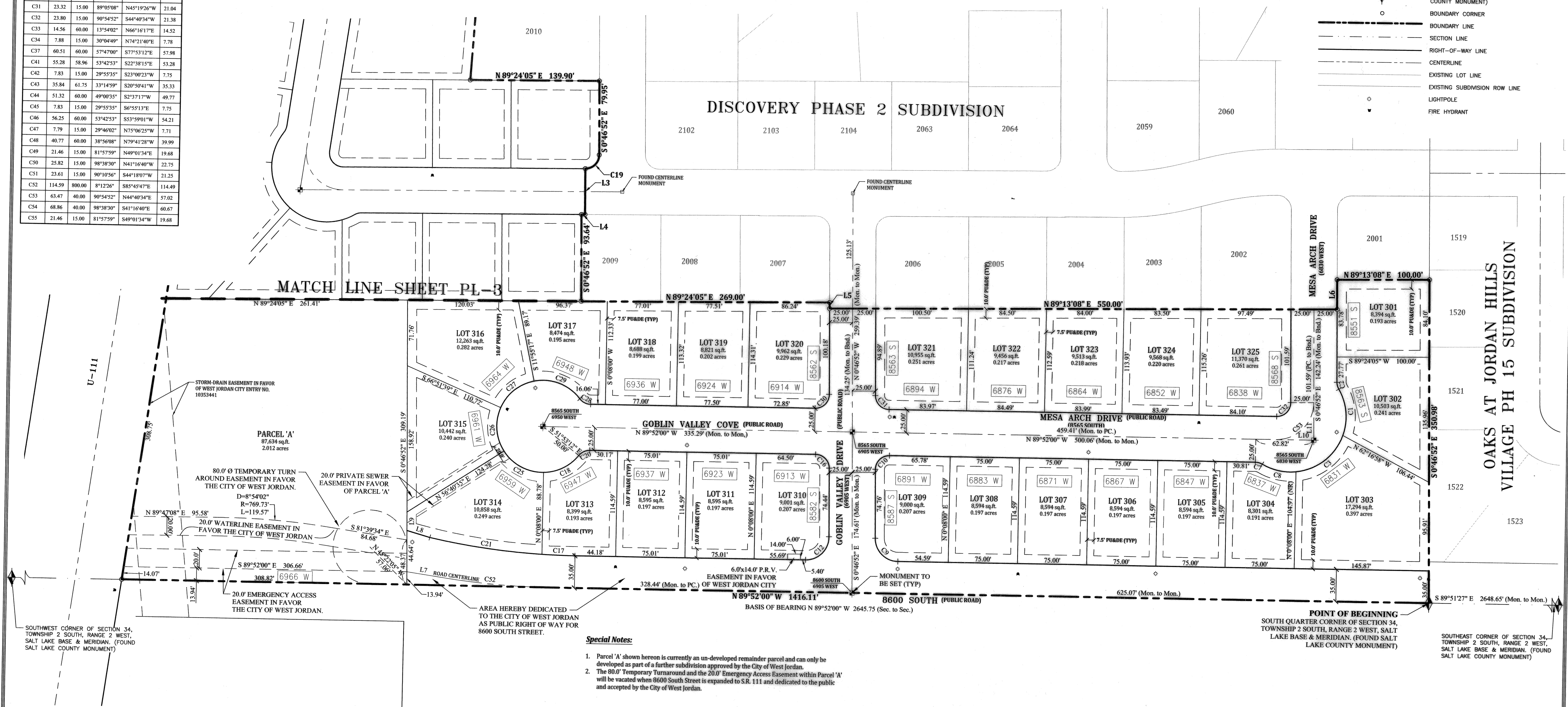
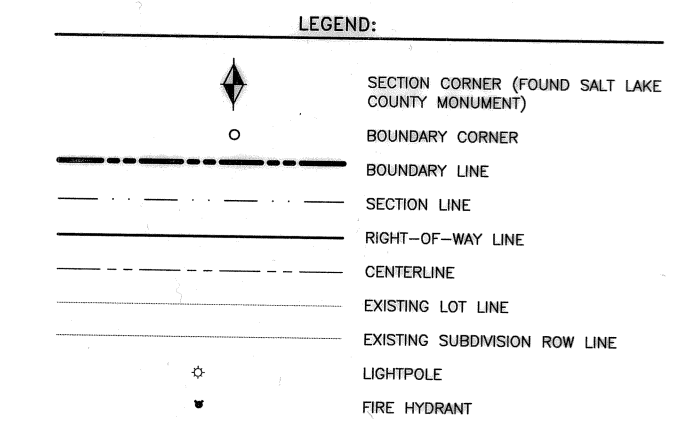
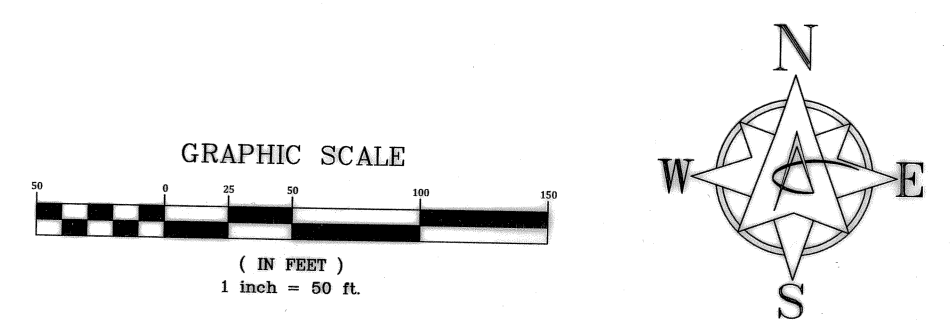

- Special Notes:**
- Parcel 'A' shown hereon is currently an un-developed remainder parcel and can only be developed as part of a further subdivision approved by the City of West Jordan.
  - The 80.0' Temporary Turnaround and the 20.0' Emergency Access Easement within Parcel 'A' will be vacated when 8600 South Street is expanded to S.R. 111 and dedicated to the public and accepted by the City of West Jordan.



SALT LAKE COUNTY RECORDER  
 STATE OF UTAH, COUNTY OF SALT LAKE, RECORDED AND FILED AT THE REQUEST OF: **IMBY DEVELOPMENT**  
 DATE: 11/10/2010 TIME: 2:50 PM BOOK: 2027 PAGE: 140  
 FEES: \$116.00  
 PRINTED NAME OF COUNTY RECORDER: *Paula Withers*

**Ward Engineering Group**  
 Planning • Engineering • Surveying  
 231 West 800 South Suite A  
 Salt Lake City, Utah 84101  
 Phone: (801)487-8040 Fax: (801)487-8668

SHEET  
 PL-2

# BRIDGEPORT SUBDIVISION

## A AMENDMENT OF LOT 1, WEST JORDAN MIDDLE SCHOOL NO. 2 SUBDIVISION

LOCATED IN THE SOUTHWEST QUARTER OF SECTION 34, TOWNSHIP 2 SOUTH, RANGE 2 WEST, SALT LAKE BASE AND MERIDIAN, LOCATED IN WEST JORDAN CITY, COUNTY OF SALT LAKE, STATE OF UTAH  
CONTAINS: 790,127 SQUARE FEET, OR 18.138 ACRES IN 57 LOTS AND 1 PARCEL

Curve #	Length	Radius	Delta	Bearing	Chord
C1	52.05	60.00	49°42'22"	N5°51'16"W	50.44
C2	7.83	15.00	29°55'35"	N15°44'40"W	7.75
C3	67.73	59.82	64°51'57"	N51°19'30"E	64.17
C7	7.83	15.00	29°55'35"	S74°54'12"E	7.75
C8	38.12	60.34	36°11'43"	S78°08'40"E	37.49
C9	38.87	25.00	89°05'08"	N45°19'26"W	35.07
C10	23.80	15.00	90°54'52"	N44°40'34"E	21.38
C12	39.67	25.00	90°54'52"	S44°40'34"W	35.64
C16	23.32	15.00	89°05'08"	S45°19'26"W	21.04
C17	35.64	78.50	2°41'32"	N88°31'14"W	35.64
C18	43.80	50.00	50°11'25"	N63°12'30"E	42.41
C19	23.61	15.00	90°11'56"	S44°18'37"W	21.25
C20	13.62	15.00	52°01'12"	N64°07'24"E	13.16
C21	122.95	758.50	9°17'15"	N82°31'50"W	122.82
C25	50.94	50.00	58°22'23"	S62°30'36"E	48.77
C26	49.27	50.00	56°27'46"	S5°05'32"E	47.30
C27	47.94	50.00	54°56'22"	S50°36'32"W	46.13
C28	13.62	15.00	52°01'12"	N63°51'24"W	13.16
C29	55.92	50.00	64°04'30"	N69°53'02"W	53.05
C30	23.80	15.00	90°54'52"	S44°40'34"W	21.38
C31	23.32	15.00	89°05'08"	N45°19'26"W	21.04
C32	23.80	15.00	90°54'52"	S44°40'34"W	21.38
C33	14.56	60.00	13°54'02"	N66°16'17"E	14.52
C34	7.88	15.00	30°04'49"	N74°21'40"E	7.78
C37	60.51	60.00	57°47'00"	S77°53'12"E	57.98
C41	55.28	58.96	53°42'53"	S22°38'15"E	53.28
C42	7.83	15.00	29°55'35"	S23°00'23"W	7.75
C43	35.84	61.75	33°14'59"	S20°50'41"W	35.33
C44	51.32	60.00	49°00'35"	S2°37'17"W	49.77
C45	7.83	15.00	29°55'35"	S6°55'13"E	7.75
C46	56.25	60.00	53°42'53"	S53°59'01"W	54.21
C47	7.79	15.00	29°46'02"	N75°06'25"W	7.71
C48	40.77	60.00	38°56'08"	N79°41'28"W	39.99
C49	21.46	15.00	81°57'59"	N49°01'34"E	19.68
C50	25.82	15.00	98°38'30"	N41°16'40"W	22.75
C51	23.61	15.00	90°10'56"	S44°18'07"W	21.25
C52	114.59	800.00	8°12'26"	S85°45'47"E	114.49
C53	63.47	40.00	90°54'52"	N44°40'34"E	57.02
C54	68.86	40.00	98°38'30"	S41°16'40"E	60.67
C55	21.46	15.00	81°57'59"	S49°01'34"W	19.68

Line #	Length	Direction
L1	8.02	N89°59'26"W
L2	4.56	N89°59'26"W
L3	50.00	S0°35'55"E
L4	3.79	S89°24'05"W
L5	6.57	S0°46'52"E
L6	32.14	N0°46'52"W
L7	40.22	S81°39'34"E
L8	25.85	N74°01'53"W
L9	19.94	N0°46'52"W
L10	40.64	S89°52'00"E
L11	40.64	N0°46'52"W
L12	46.54	S89°24'05"W
L13	46.54	N8°02'35"E
L14	13.03	N89°59'26"W
L15	13.03	N8°02'35"E

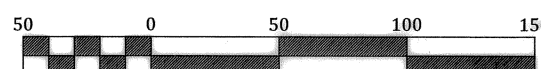
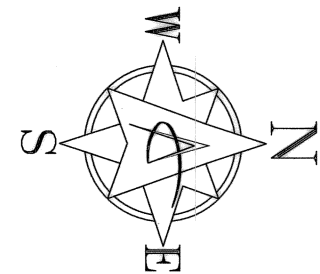

Scale 1" = 50'

LEGEND:	
	SECTION CORNER (FOUND SALT LAKE COUNTY MONUMENT)
	BOUNDARY CORNER
	BOUNDARY LINE
	SECTION LINE
	RIGHT-OF-WAY LINE
	CENTERLINE
	EXISTING LOT LINE
	EXISTING SUBDIVISION ROW LINE
	LIGHTPOLE
	FIRE HYDRANT

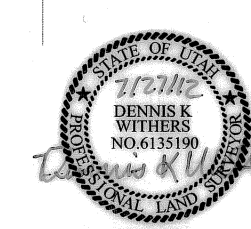
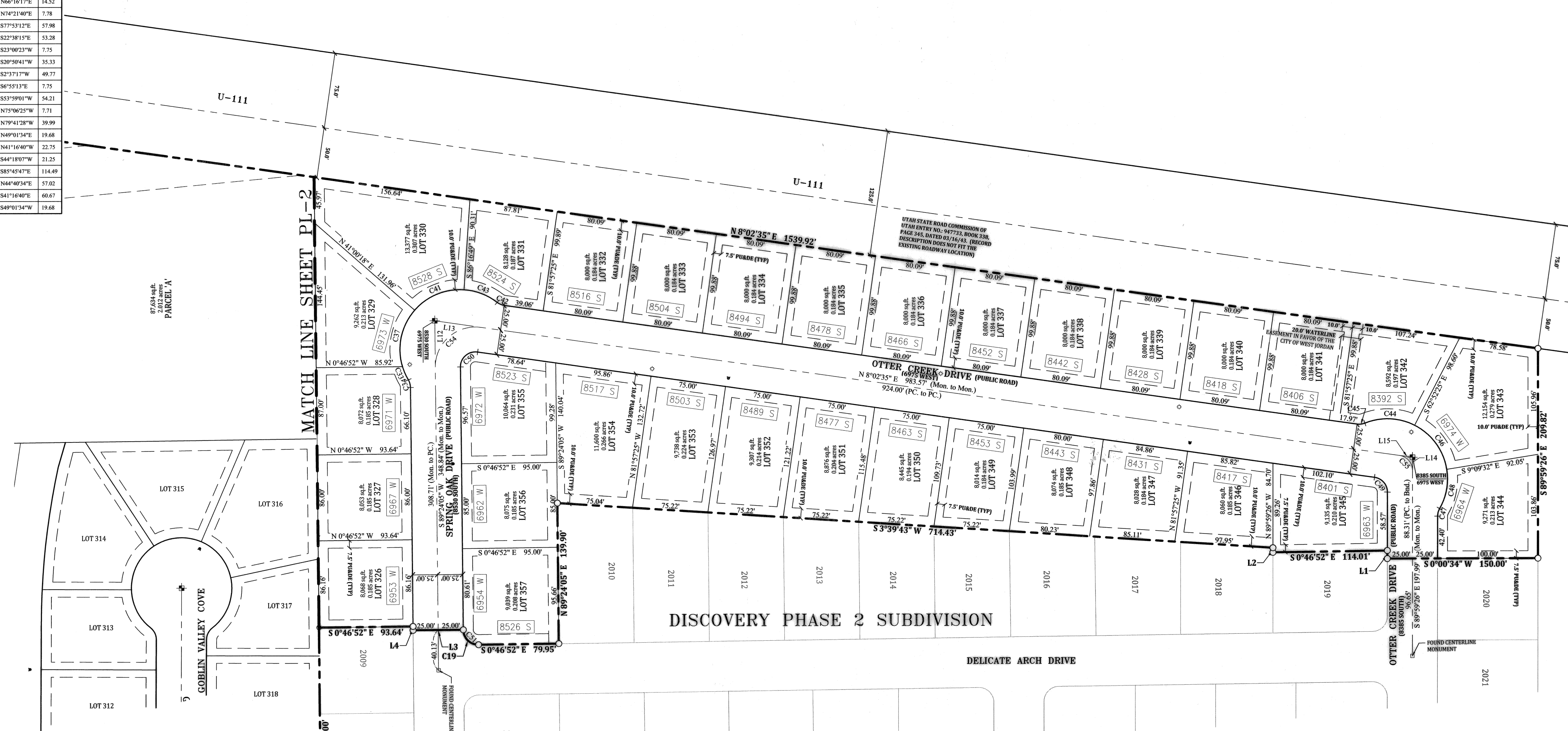

SALT LAKE COUNTY RECORDER 11472115  
RECORD NO.  
STATE OF UTAH, COUNTY OF SALT LAKE, RECORDED AND FILED  
AT THE REQUEST OF: Ward Engineering Group  
DATE: 9/19/2012 TIME: 10:24 AM BOOK: 2012 PAGE: 140  
FEES: \$ 145.00  
PRINTED NAME OF COUNTY RECORDER: Dennis K. Withers

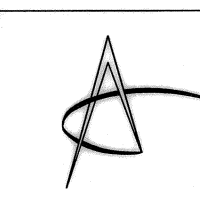

**Ward Engineering Group**  
Planning • Engineering • Surveying  
231 West 800 South Suite A  
Salt Lake City, Utah 84101  
Phone: (801)487-8040 Fax: (801)487-8668

SHEET  
PL-3