

91
24

ENT 20263 BK 4981 PG 851
RANDALL A. COVINGTON
UTAH COUNTY RECORDER
1999 Feb 19 2:01 pm FEE 91.00 BY SS
RECORDED FOR TOWN OF EAGLE MOUNTAIN
Cent.

DECLARATION OF COVENANTS, CONDITIONS & RESTRICTIONS

ROCKWELL VILLAGE AT REDHAWK RANCH SUBDIVISION

THIS DECLARATION OF Covenants, Conditions and Restrictions is made this 10th day of February, 1998 by The Ranches, LC, a Utah Corporation whose project is known as Rockwell Village at RedHawk Ranch (hereinafter "Declarant"). The Town of Eagle Mountain is included as a party Declarant in this Declaration of Covenants, Conditions and Restrictions; the Town of Eagle Mountain is not the record owner of property but is included as a Declarant for the purpose of permitting the Town of Eagle Mountain to enforce certain Covenants, Conditions and Restrictions concerning architectural guidelines.

WHEREAS Rockwell Village at Redhawk Ranch is an area of unique natural beauty, featuring distinctive terrain; and

WHEREAS by subjecting Rockwell Village at Redhawk Ranch to this Declaration, it is the desire, intent and purpose of Declarant to create a community in which beauty shall be substantially preserved, which will enhance the desirability of living on those portions of Rockwell Village at Redhawk Ranch, subject to this Declaration, and which will increase and preserve the attractiveness, quality and value of the lands and improvements therein; and

WHEREAS this Declaration shall apply to the lands described on Exhibit A hereto and to such additional lands as may be hereafter subject to this Declaration in the manner set forth below in Article II.

NOW, THEREFORE, Declarant hereby declares that Rockwell Village at Redhawk Ranch is and shall henceforth be owned, held, conveyed, encumbered, leased, improved, used, occupied and enjoyed subject to the following uniform covenants, conditions, restrictions and equitable servitude. That said covenants, conditions, restrictions and equitable servitude are in furtherance of, and the same shall constitute, a general plan for the ownership, improvement, sale, use and occupancy of Rockwell Village at Redhawk Ranch and that they are also in furtherance of and designed to accomplish the desires, intentions, and purposes set forth above in the recitals. This Declaration shall run with the real property described on Exhibit A and shall inure to the benefit of and be binding upon every part thereof and every interest therein. Further the Declaration shall inure to the benefit of, be binding upon, and be enforceable by Declarant and its successors in interest and each owner and his successors in interest. The Town of Eagle Mountain is included as an additional Declarant and shall be treated as a Declarant in all circumstances.

These covenants, conditions and restrictions are subject to and, to the extent they are inconsistent with, shall be superseded by, the Master Covenants, Conditions and Restrictions to be recorded by The Ranches, L.C., Declarant of the entire project known as The Ranches at Eagle Mountain, of which this Rockwell Village at RedHawk Ranch is a part. The subordination of these covenants, conditions and restrictions to the Master Covenants, Conditions and Restrictions shall be recorded in the future and is not subject to the approval or of any buyers of lots or homes in Rockwell Village at Redhawk Ranch.

This Declaration shall be recorded and may be enforced as provided for herein.

ARTICLE I

DEFINITIONS

Unless the context otherwise specifies or requires, the following words and phrases when used in the Declaration shall have the meanings hereinafter specified.

SECTION 1.01. **The Ranches Master Homeowners Association Design Review Committee** shall mean the committee created pursuant to Article IX hereof.

SECTION 1.02. **Design Review Committee Rules** shall mean the rules adopted by the Design Review Committee pursuant to Article IX hereof.

SECTION 1.03. **Assessments** shall mean the sums levied for the purposes set forth in Articles XI and XII hereof.

SECTION 1.04. **Beneficiary** shall mean a mortgagee under a mortgage, a beneficiary under a deed of trust, or a seller under a title retaining contract, as the case may be.

SECTION 1.05. **Board** shall mean the Board of Trustees of the Master Homeowners Association, as appropriate.

SECTION 1.06. **Declarant** shall mean The Ranches, LC or the Town of Eagle Mountain as the context requires.

SECTION 1.07. **Deed of Trust** shall mean a mortgage, a deed of trust, or a title retaining contract, as the case may be, granted on a Lot to secure the payment of a debt.

SECTION 1.08. **Improvement** shall mean every structure and all appurtenances thereto of every type and kind, including but not limited to buildings, outbuildings, patios, tennis courts, swimming pools, garages, doghouses, mailboxes, aerials, antennas, roads, driveways, parking areas, fences, screening walls, retaining walls, stairs, decks, landscaping, hedges, windbreaks, planting, planted trees and shrubs, poles, signs, exterior air conditioning, water softener fixtures or equipment, pumps, wells, tanks, reservoirs, pipes, lines, meters, towers, and other facilities used in connection with water, sewer, gas, electric, telephone, regular or cable television, or other utilities.

SECTION 1.9. **Rockwell Village at RedHawk Ranch** shall mean Rockwell Village Subdivision..

SECTION 1.10. **Lot** shall mean any unit of land which is designated on any recorded Subdivision Plat of Rockwell Village at Redhawk Ranch whether or not improved.

SECTION 1.11. **Manager** shall mean any person, firm or corporation employed by the Master Homeowners Association pursuant to Article X hereof and delegated duties, powers, or functions by the Association.

SECTION 1.12. **Mortgage** shall mean any mortgage deed of trust or title retaining contract granted on a Lot to secure the payment of a debt.

SECTION 1.13. **Exterior Materials** shall mean stone, rock, stucco, finished lumber, brick, vinyl siding or siding that has the appearance of wood, or other similar materials but shall not mean cinder block or concrete block or aluminum siding. Exterior residence materials shall be of a noncombustible material as approved by the Town of Eagle Mountain. Outbuildings need not be constructed of non-combustible materials. The determination as to if any specific material constitutes an acceptable Exterior Material as its use is proposed in a given structure in Rockwell Village at Redhawk Ranch shall be made by the Design Review Committee.

SECTION 1.14. **Notice and Hearing** shall mean ten (10) days written notice given and a public hearing at which the person to whom the notice is directed shall have the opportunity to be heard in person or by counsel at his expense.

SECTION 1.15. **Owner** shall mean (1) the person or persons, including Declarant and, holding an aggregate fee simple interest in a Lot or, as the case may be, (2) the purchaser of an aggregate fee simple interest in a Lot under an executory contract sale.

SECTION 1.16. **Person** shall mean a natural individual or any other entity with the legal right to hold title to real property.

SECTION 1.17. **Plans and Specifications** shall mean any and all documents designed to guide or control the construction or alterations or improvements or other proposal in question, including but not limited to documents indicating the size, shape, configuration and/or materials, to be incorporated; all site plans, excavation and grading plans, elevation drawings, floor plans, techniques, samples of exterior colors, plans for utility services, and all other documentation or information relevant to the improvement or proposal in question.

SECTION 1.18. **Rockwell Village at Redhawk Ranch** shall mean all lands described on Exhibit A attached hereto and all lands which may be hereafter subjected to this Declaration pursuant to Article II from and after such subjection.

SECTION 1.19. **Record, Recorded, and Recordation** shall mean, with respect to any document, the recordation of such document in the office of the Recorder of Utah County.

SECTION 1.20. **Subdivision** shall mean a parcel of land, which has been shown on a final and recorded subdivision plat consisting of two or more lots.

SECTION 1.21. **Declaration** shall mean this instrument as it may be amended from time to time.

SECTION 1.22. **Period of Declarant's Control** shall mean a period from the date of recording of this Declaration until the later to occur of the events set forth in Section 10.02.

ARTICLE II

SUBJECTION OF LAND TO THIS DECLARATION

SECTION 2.01. Declarant may at any time and from time to time subject additional Real Property to the provisions of this Declaration in accordance with the procedures set out in this Article II. Upon the recording of a Notice of Addition of Real Property containing the provisions set forth below in this Article, the covenants, conditions, restrictions and equitable servitude's contained in this Declaration shall apply to such additional Real Property in the same manner as to the Real Property originally subject to this Declaration and thereafter, the rights, privileges, duties and liabilities of all persons subject to this Declaration shall be the same with respect to all additional Real Property as with respect to all additional Real Property as with respect to the property originally covered by this Declaration.

The Notice of Addition of Real Property referred to herein above shall contain the following provisions:

- A. A reference to this Declaration, which reference shall state the date of recordation hereof and the book and page numbers wherein this Declaration is recorded.
- B. A statement that the provisions of this Declaration shall apply to the additional Real Property as set forth herein.
- C. A complete adequate legal description of the added land; and
- D. Declarant's written consent.

ARTICLE III

BASIC BUILDING RESTRICTIONS

SECTION 3.01. **Use of Property.** Each Lot shall be used solely for residential purposes.

SECTION 3.02. **Design Review Committee Approval.** The Plans and Specifications, including the location of all improvements must be approved in writing by the Design Review Committee prior to commencement of any construction in accordance with and subject to the provisions of Article IX hereof.

SECTION 3.03. **Architecture - Elevation Articulation Ratio (EAR).** The elevation articulation ratio is intended to establish a measure of acceptable architectural material and massing for an elevation. This ratio shall be established for all elevations of a dwelling as well as averaged in order to meet the minimum requirements. The EAR ratio shall be meet the criteria of The Ranches Design Guidelines as recorded by the County Recorder in Utah County, Utah for "Entry Level Neighborhoods".

SECTION 3.04. Property Line Setbacks. Any structures to be constructed on a Lot shall comply with the following minimum property line setbacks as defined in The Ranches Community Design Guidelines as recorded by the Utah County Recorder, Utah County for "Entry Level Neighborhoods".

SECTION 3.05. Floor Space. The minimum size of each single story, bi-level or tri-level dwelling unit shall meet the criteria of The Ranches Design Guidelines as recorded by the County Recorder in Utah County, Utah for "Entry Level Neighborhoods".

SECTION 3.06. Exterior Surfaces. All exterior surfaces of any building shall be of materials and of colors approved by the Design Review Committee and as specified in Article 1.14. But, in no case shall vinyl siding consist of more than 25% of the materials on the exterior surfaces.

SECTION 3.07. Roofs. All roofs shall be of a minimum twenty-five (30) year architectural grade asphalt shingles, tile or wood shingles, and pitch or slope shall be a minimum of 6:12 or greater is preferred. Gutters shall be required to drain all roof areas.

SECTION 3.08. Roof Overhang. A minimum twelve (12) inch eave overhang with boxed soffit shall be required.

SECTION 3.09. Height. No building shall exceed thirty five feet in height measured from the highest natural ground level adjacent to such building to the highest point of the ridge line of such building.

SECTION 3.10. Garages. An enclosed garage of at least 400 square feet capable of parking a minimum of two (2) automobiles and a maximum of four (4) automobiles shall be constructed on each Lot. Said garage is encouraged to be attached to the residential structure (dwelling) and is encouraged to be side loaded or accessible from an alley. Detached garages may provide garage doors which are oriented to the public street only if the garage is setback a minimum of thirty (30) feet from the adjacent street or flush with the front elevation. However, the garage elevations must meet the criteria of The Ranches Community Design Guidelines.

SECTION 3.11. Garage Doors. Side loaded garages shall have a minimum combined window area of 30 square feet required on the front elevation. Garage doors shall not be flush with the elevation on which they are placed but shall be recessed a minimum of six (6) inches. Sectional garage doors with decorative panels shall be required.

SECTION 3.12. Porches and Covered Entries. Front porches and/or covered entries shall be required on all front and Public Street facing elevations. Front porches/covered entries shall measure a minimum of eighty (80) square feet and shall be a minimum of eight (8) feet deep. A minimum porch column size of six (6) inches by six (6) inches with trimmed cap shall be required. Porches shall not occupy more than 40 percent of the linear frontage of the front elevation. All exposed porch /covered entry railings shall be stained, painted, or vinyl clad.

SECTION 3.13. Materials. Reflective glass materials and finishes shall be prohibited. All exterior building materials shall be one-hour fire rated and must be approved prior to construction by the Design Review Committee.

SECTION 3.14. Foundations. A maximum of eight (8) inches of exposed concrete foundation shall be permitted. A maximum of twenty (20) inches of exposed concrete shall be permitted on elevations where the grade slopes along the dwelling. Concrete Masonry Units (CMU) used for foundation purposes shall be painted to match the main dwelling.

SECTION 3.15. Windows. A minimum of one window on each elevation of a dwelling shall be required. Metal windows shall be prohibited.

SECTION 3.16. Decks. Decks shall be integrated with the architecture of the main dwelling. Covered deck roof forms shall be consistent with the slope of the main dwelling roof. Deck supporting posts shall be eight inches or greater. Exposed wood deck elements shall be painted or stained.

SECTION 3.17. Siding. On sided homes, a minimum of six (6) inches of trim at the window heads and four (4) inches of trim at window jambs and sills shall be required. A minimum of four (4) inches of corner boards shall be required at all outside corners. Four-by-eight foot butt-jointed sheets of any material, including T-111 shall be prohibited. The maximum width of siding shall be eight (8) inches.

SECTION 3.18. Stucco. Elevations composed of stucco which surround openings shall integrate one of the following design standards:

- a) Provide header and sill details.
- b) Provide trim at all four corners.
- c) Provide a two (2) inch minimum recess from the facade face.

SECTION 3.19. New Construction. All dwelling units shall be of new construction. No other building (including but not limited to playhouses, and storage sheds) may be moved onto a Lot without the prior written approval of the Design Review Committee. Prefabricated, pre-manufactured, etc., residences may be constructed, assembled or moved onto a Lot with prior approval of the Design Review Committee and providing all other conditions and restrictions of the Rockwell Village at Redhawk Ranch subdivision are met.

SECTION 3.20. Outbuildings. No Lot shall have more than 1 (one) outbuilding. All outbuildings shall be architecturally compatible with the residence as to design and materials, and shall be approved prior to construction by the Design Review Committee. Detached garages shall be counted as one (1) outbuilding.

SECTION 3.21. Storage of Building Materials. No building materials shall be stored on any Lot except temporarily during construction of an improvement or its alteration, renovation or remodeling, and then only when a building permit is in force.

SECTION 3.22. Occupancy During Construction. No improvement structure shall be occupied in the course of original construction until all required certificates of occupancy have been issued by the appropriate governmental authorities. All work of construction shall be prosecuted diligently and continuously from the time of commencement until completed within nine (9) months from the date that site excavation was commenced.

SECTION 3.23. Temporary Structures. No trailer, mobile home, tent, shack or other temporary building, improvement or structure shall be placed upon any property without the prior approval of the Design Review Committee except that temporary structures necessary for storage of tools and equipment and for office space for architects, sales personnel, builders and foremen during actual construction may be maintained with the prior approval of the Design Review Committee, such approval to include the nature, size and location of such structure.

SECTION 3.24. Construction Activities. This Declaration shall not be construed so as to unreasonably interfere with or prevent normal construction of improvements by any Owner, provided that when completed such improvements shall in all ways conform to this Declaration. Specifically, no such construction activities shall be deemed to constitute a nuisance or a violation of this Declaration by reason of noise, dust, presence of vehicles or construction machinery, posting of signs, or similar activities, provided that such construction is pursued to completion with reasonable diligence, is in compliance with applicable federal, state and local laws and ordinances and any rules and regulations adopted pursuant thereto, and conforms to usual construction practices in the area. In the event of any dispute, a temporary waiver of the applicable provision, including but not limited to any provision prohibiting temporary structures, may be granted by the Design Review Committee, provided that such waiver shall be only for the reasonable period of such initial construction. Such waiver may, but need not, be recorded or in recordable form.

SECTION 3.25. Driveways. Driveways for dwellings shall be large enough to accommodate at least two (2) parked automobiles. Hard surface driveways shall be properly maintained and patched.

SECTION 3.26. Mail Box. Each Lot when improved shall have a Mail Box and post in compliance with the details and designated colors shown in Exhibit C. Any additional addressing, naming, etc. will be with the approval of the Design Review Committee.

ARTICLE IV

ANIMALS

Animals kept on any Lot shall be properly fenced, sheltered and cared for. All dogs shall be kept on a hand-held leash except when on their Owner's own Lot. Each Owner shall maintain and clean facilities for their pets and no objectionable odors, pests, insects, etc. No animal or other pet of any kind other than common domesticated animals shall be allowed, including but not limited to cats and dogs which in the opinion of the Association's Board might be dangerous or which makes an unreasonable amount of noise or odor or is a nuisance. Each Owner of pets and animals shall be financially responsible and liable for any damage caused by said Owner's pets and animals and shall be responsible for the pickup and disposal of any excrement deposited by his pets and animals.

ARTICLE V

COMMON AREA AMENITIES

SECTION 5.01. Parks. Located in the Rockwell Village at Redhawk Ranch Subdivision is one (1) site which will be designated as a park. This will be made available to all Lot Owners, tenants and their accompanied guests or invitees. The parks shall be maintained by the Ranches Master Homeowner's Association, Inc.

SECTION 5.02. Motorized Vehicles. No motorized vehicles (autos, trucks, bicycles, motorcycles, ATV's, etc.) shall be permitted in the park nor along the pedestrian/bridal paths.

SECTION 5.03. Supervision and Responsibilities. There is no supervision of the park area, the pedestrian/bridle path or their prescribed uses. These shall be used at the sole risk and responsibility of the members and their guests, invitees and tenants. Any damage to any homeowner or association property or personal injury shall be the responsibility of the individual causing such. In the case of damage caused by any member, tenants, guests, or invitees of the member, the member is responsible.

ARTICLE VI

UTILITIES

SECTION 6.01. To Be Underground. Each Lot shall be and is hereby made subject to all easements that now or in the future may be used for gas, electric, telephone, cable television, water, sewer, and other lines present or in the future as are necessary to provide utility services to said Lot, adjoining Lots, and the improvements thereon. Each Owner hereby agrees to execute such further grant or other documentation as may be required by any utility or other company or public governmental or quasi-governmental entity for such purposes. Subsequent to date of execution of the Declaration, any necessary electrical, telephone, gas, water, sewer, cable television, and other utility conduits, lines and pipes on any Lot shall be placed underground. No transformer, or electric, gas, water or other meter or device of any type, or any other apparatus shall be located on any pole. All such installations shall be subject to the prior written approval of the Design Review Committee.

SECTION 6.02. Rules and Regulations. Each Owner agrees to abide by all applicable rules and regulations of all utility and other companies and public, governmental and quasi-governmental entities which supply any of the services mentioned in Section 6.01 above.

SECTION 6.03. Street Lighting. If street lights are installed, all Lots shall be subject to and bound by The Town of Eagle Mountain tariffs which are now effective or may in the future and assessments made by The Town of Eagle Mountain relating to street lighting, together with rates, rules and regulations therein provided, and subject to all future amendments and changes thereto so approved. The Owner of each Lot shall pay as billed a portion of the cost of street lighting according to The Town of Eagle Mountain rates, rules and regulations, including future amendments and changes, on file with and approved by the The Town of Eagle Mountain. Notwithstanding the foregoing Declarant shall be obligated to install street lights as required by The Town of Eagle Mountain.

ARTICLE VII

USE AND RESTRICTIONS

SECTION 7.01. **Antennas.** Aerials or antennas for reception of radio or television or other electronic signals shall be installed so as to not be unsightly. Such shall not be maintained at any location so as to be visible from adjacent streets without written approval of the Design Review Committee.

SECTION 7.02. **Transmitters.** No electronic or radio transmitter of any kind, other than garage door openers, shall be located or operated in or on any improvement or on any Lot without the prior written approval of the Design Review Committee.

SECTION 7.03. **Repair of Buildings.** No improvement upon any Lot shall be permitted to fall into disrepair, and each such improvement shall at all times be kept in good condition and repair and adequately painted or otherwise finished by the Owner before the surfacing becomes weather beaten or worn off. Materials which are customarily left unfinished, such as cedar shake shingle roofs and cedar stockade fences, are permitted so long as in the opinion of the Design Review Committee they have not become unsightly.

SECTION 7.04. **Reconstruction of Buildings.** Any improvement which has been destroyed in whole or in part by fire, hail, windstorm or any other cause or act of God, shall be rebuilt or restored with reasonable promptness, and in any event within nine (9) months. Further, all debris shall be removed and Lot restored to a slightly condition within thirty (30) days.

SECTION 7.05. **Nuisances.** No rubbish or debris of any kind shall be placed or permitted to accumulate upon any Lot and no odors shall be permitted to arise therefrom so as to render any such property or any portion thereof, in the opinion the Association's Board, unsanitary, unsightly, offensive or detrimental to any other property or to its occupants. No noise or other nuisance shall be permitted to exist or operate upon any Lot so as to be, in the opinion of the Association's Board, offensive or detrimental to any other property or its occupants. Without limiting the generality of any of the foregoing provisions, no exterior speakers, horns, whistles, bells or other sound devices (other than security devices used exclusively for security purposes) shall be located, used or placed on any Lot without the prior written approval of the Board.

SECTION 7.06. **Unsightly Articles.** No unsightly article shall be permitted to remain on any Lot or on streets and drives within Rockwell Village at Redhawk Ranch but must be stored on an off-site storage area in compliance with The Town of Eagle Mountain Development Code. Without limiting the generality of the foregoing, trailers, mobile homes, recreation vehicles, graders, trucks (other than pickups used solely for the private and non-business use of the residents of a lot), boats, tractors, campers, wagons, buses, sleighs, motorcycles, motor scooters, snowmobiles, snow removal equipment, garden and maintenance equipment, and all commercial, farming and business vehicles, except when in actual use, shall be kept at all times in a off-site storage facility. No repair or maintenance work shall be done on any of the foregoing; or on any automobile, other than minor emergency repairs, except in an enclosed garage or other structure. Refuse, garbage and trash shall be kept at all times in a covered, noiseless container and any such container shall be kept within an enclosed structure or appropriately screened from view. Service areas, storage areas, compost piles and facilities for hanging, drying or airing clothing or household fabrics shall be appropriately screened from view. No materials or scrap shall be kept, stored or allowed to

accumulate on any property except within an enclosed structure or if appropriately screened from view. Liquid propane gas, oil and other exterior tanks shall be kept within an enclosed structure or permanently screened from view. Family vehicles, which are kept in good repair and driven regularly, may be parked in the driveway.

SECTION 7.07. Signs. No sign of any kind shall be displayed to the public view on any Lot provided however, that signs which have received the prior approval of the Design Review Committee may be displayed on or from a residence advertising the residence for sale or lease as shown in Exhibit B. Signs used for sale, administration and directional purposes during development of Rockwell Village at Redhawk Ranch will be permitted provided they are first approved by the Design Review Committee. All signs must be professionally painted, lettered and constructed.

SECTION 7.08. Residential Use Only. Homes shall have the appearance of single family residences. No Lot and no residence on any lot shall be used for any purpose other than for a residence. However, nothing in this Declaration shall prevent the rental of a Lot by the Owner thereof for residential purposes, on either a short or long-term basis subject to all the provisions of this Declaration and the requirement that all such leases shall be in writing and that a violation of any of the restrictions, covenants, and conditions set forth herein shall be a default under such Lease.

SECTION 7.09. Hazardous Activities. No activities shall be conducted on any Lot and no improvements shall be constructed on any Lot which are or might be unsafe or hazardous to any person or property. Without limiting the generality of the foregoing, no firearms shall be discharged upon any Lot, and no open fires shall be lighted or permitted on any Lot except as permitted by the Town of Eagle Mountain, or except in a contained barbecue unit while attended and in use for cooking purposes or within a safe and properly designed interior fireplace.

SECTION 7.10. Garage Sales. No garage, patio, porch or lawn sale shall be held on any Lot, except that the Owner of any Lot may conduct such a sale if the items sold are only his own furniture and belongings, not acquired for purposes of resale; if such sale is held at such time and in such manner as not to disturb any other resident of the area and if such sale is held in full compliance with all applicable governmental ordinances, statutes, resolutions, rules and regulations.

SECTION 7.11. Erosion and Dust Control. In addition to all other measures taken to prevent or eliminate nuisances and conditions that are unsightly and detrimental to any other property or its occupants, in the cases of animals, vehicles, etc., adequate measures (including proper range and grazing techniques, seeding and maintaining natural vegetation such as dry grasses, wild flowers, etc.) shall be taken to maintain appropriate ground cover to prevent and control erosion and dust.

ARTICLE VIII

LANDSCAPING AND DRAINAGE

SECTION 8.01. Approval. Prior to commencement of any construction of any landscaping fence, screening wall, retaining wall, arbor, gazebo, patio cover, roof or landscaping (including lawns, ground cover or flowers), and prior to any planting of trees or shrubs, approval of the Design Review Committee shall be obtained pursuant to Article IX hereof.

SECTION 8.02. Completion of Landscaping. Upon completion of construction of a dwelling on any Lot or occupancy, whichever occurs last, between March 1, and September 1, or within one hundred eighty (180) days after completion of such construction or occupancy, whichever occurs last, at any other time of the year, if occupancy occurs during a period when landscaping cannot be installed the builder/owner will have to escrow with The Ranches or a title company designated by The Ranches the estimated cost of the landscaping. All front yard areas shall be landscaped in accordance plans approved by the Design Review Committee and thereafter carefully maintained. All Lots shall be kept free from plants infected with noxious insects or plant diseases which in the opinion of the Design Review Committee are likely to spread to other property, and all Lots shall be kept free from weeds.

SECTION 8.03. Front Yard Landscaping. The front yard of a lot is defined as the area of the Lot beginning at the front property line on any adjacent public street to a distance at least to the rear most part of the residence from the public street. This area is to be planted or sodded or maintained in a natural and native material or setting as approved by the Design Review Committee. This area is to be irrigated as necessary, cut and or maintained to reflect a weed-free attractive appearance. Each residence shall be surrounded by irrigated green space.

Front lawns shall have a minimum turf coverage of 50 percent. Corner lots shall have up to 75 percent turf coverage. Greater percentages of turf coverage are permitted if drought tolerant turf grasses are used. All turf areas shall be permanently irrigated with an automatic irrigation system.

Planting beds shall be 50 percent covered by plant material at the time of installation. After three (3) years, plants shall cover 75 percent of the planting beds. Seasonal flowers shall qualify as cover.

Marble chips, volcanic rock, or high contrast stone patterns (i.e., red, green, white, black) shall not be allowed. Natural earth tone stone material, such as washed river rock, may be used.

SECTION 8.04. Trees. When a Lot is improved with a dwelling and is landscaped, the following criteria for tree planting shall be followed in the front yard:

- A. A minimum of three (3) trees shall be planted on the Lot within the time outlined in Section 8.02.
- B. Of the three (3) trees minimum to be planted, at least one (1) deciduous trees with a minimum one (1) inch caliper (the diameter of the tree ten (10) inches above the top of root-ball), shall be planted. The species of these trees and the plantings shall be as per Town requirements along the front property line.
- C. Of the three (3) trees, one (1) additional deciduous trees of a minimum one-half (1/2) inch caliper shall be planted elsewhere on the Lot. (On corner Lots these two (2) trees shall be one (1) inch caliper and planted on the front property line).

- D. Of the three (3) trees minimum to be planted, at least an additional evergreen tree of at least five (5) ft. in height (measured from the top of the root-ball to the top of the tree) shall be planted.

SECTION 8.05. Rear Yard Maintenance. The rear yard of each Lot is to be maintained in native vegetation, grasses, gardens, irrigated pasture, crops, etc. Such is to be tended, mowed, etc., to keep the rear yard free of weeds, trash, and debris. The height of any growth shall not exceed twelve (12) inches except in the case of natural sage brush, trees and agricultural crops which shall be harvested timely.

SECTION 8.06. Fencing. All fencing shall be approved in accordance with Article 9.01. No barbed wire fencing is permitted. All fencing and landscaping shall be subject to the Design Review Committee Guidelines and approval. No lot owner shall remove, add to, alter, stain or paint the front fencing without consent of the Design Review Committee. Side fencing may be installed by the lot owner. No fencing may be installed by the lot owner in the front yard, (or the side yard adjacent to a Public Street on a corner lot), of a home, except that it may extend toward the side property lines only as far forward as the front corners of the home.

SECTION 8.07. Road Rights of Way. The Ranches Master Homeowner's Association will maintain the area from the edge of road pavement to the front Lot line as needed and supplementing Town of Eagle Mountain maintenance to insure weed control, grass and vegetation height, uniform appearance, etc. Lot Owners shall maintain the respective areas in front of their Lots free of debris, etc.

SECTION 8.08. Maintenance of Unimproved Lot. Lot Owner is responsible from the date of receipt of deed to the Lot to maintain that unimproved Lot is free and clear of weeds, trash and debris. The Lot shall be mowed at least twice per year to maintain growth below twelve (12) inches in height except in the case of natural sage brush, trees and agricultural crops which shall be harvested timely.

SECTION 8.09. Drainage. No material change may be made in the ground level, slope, pitch or drainage patterns of any Lot as fixed by the original finish grading except after first obtaining the prior written approval of the Design Review Committee. Grading shall be maintained at all times so as to conduct irrigation and surface waters away from buildings and so as to protect foundations and footings from excess moisture. Any drainage flows directed to adjacent Lots shall not exceed historic flows. Owners shall not impede or retain water flow in any of the natural drainage gulches.

SECTION 8.10. Entries and Monuments. In Rockwell Village at Redhawk Ranch, entry structures may be placed on footprint easements on the Entry Lots. Such structures shall be maintained by the Ranches Master Homeowner's Association. The Ranches Master Homeowner's Association or its designated agents have right of access to perform maintenance. Lot Owners may not obstruct the view, attach any improvement, including fencing, to, against, or in front of such structures. Lot Owners will maintain their Lots adjacent to the entry structures. The Association will maintain all entries including landscaping, monuments, walls, etc.

ARTICLE IX

THE RANCHES MASTER HOMEOWNER'S ASSOCIATION

SECTION 9.01. Approval Required. No improvement, building, fence, wall or other structure shall be commenced, erected, repaired, altered, added to or maintained until the Plans and Specifications showing the nature, kind, shape, height, materials, floor plans, exterior color scheme and location of such structure, and the grading plan and finished grade elevations of the Lot to be built upon shall have been submitted to and approved by the Design Review Committee hereinafter described and a copy thereof, provided by the owner as finally approved, lodged permanently with said Committee pursuant to the provisions of this Article. No landscaping on any Lot shall be done until a landscaping plan shall have been submitted to and approved by such Committee. Such Committee shall have the right to refuse to approve any such Plans or Specifications or grading or landscaping plans which are not suitable or desirable in the Committee's opinion, for aesthetic or other reasons, and in so passing upon such plans, specifications and grading and landscaping plans, the Committee shall have the right to take into considerations the suitability of the proposed building or other improvement and of the materials of which it is to be built, to the Lot upon which it proposes to erect the same, the harmony thereof with the surroundings, the topography of the land and the effect of the building or other improvements as planned on the outlook from the adjacent or neighboring Lots. All subsequent additions to or changes or alterations in any building, fence, or other improvement, including exterior color scheme and all subsequent additions to or changes or alterations in any grading or landscaping plans shall be subject to the prior approval of the Design Review Committee.

SECTION 9.02. Members of Committee. The Ranches Design Review Committee shall consist of not less than three members, nor more than six members. The following persons are hereby designated as the initial members of the Committee:

Mark Kopatz
 Kyle Harris
 Debbie Hooge

Each member of the Committee shall hold office until such time as he has resigned or has been removed or his successor has been appointed as provided herein. Members of the Committee may be removed at any time with or without cause by the Board.

SECTION 9.03. Appointment of Members. The Board shall have the right to appoint and remove all members of the Committee, except that during the period of Declarant's control, the Declarant may appoint three members of the Committee.

SECTION 9.04. Review of Proposed Construction. Whenever in this Declaration the approval of the Design Review Committee is required, it shall have the right to consider all of the Plans and Specifications for the improvement or proposal in question and all other facts which in its sole discretion are relevant. Prior to commencement of any construction of any improvement on any Lot, the Plans and Specifications therefore shall be submitted to the Design Review Committee at 9155 North Cedar Pass Rd. #B, Eagle Mountain, UT 84043, and construction thereof may not commence unless and until the Committee has approved such Plans and Specifications in writing. The Committee shall consider and act upon any and all Plans and Specifications submitted for its approval pursuant to this Declaration, or as from time to time shall be assigned to it by the Association, including the inspection of construction in progress to assure its conformance with Plans and Specifications approved by the Committee. The

Committee shall approve Plans and Specifications submitted for its approval only if it deems that the construction, alterations, or additions contemplated thereby in the locations indicated will not be detrimental to the surrounding area or Lots as a whole, and that the appearance of any structure affected thereby will be in harmony with the surrounding structures. The Committee may condition its approval of Plans and Specifications or on other information prior to approving or disapproving the material submitted. The Committee may also issue rules or guidelines regarding anything relevant to its function, including but not limited to minimum standards and procedures for the submission of Plans and Specifications for approval. The Committee may require a fifty dollar (\$50.00) fee to accompany each application for approval. The Committee may require such detail in Plans and Specifications submitted for its review and such other information as it deems proper. Until receipt by the Committee of all required Plans and Specifications and other information, the Committee may postpone review of anything submitted for approval. All improvements must comply with the zoning codes, ordinances and architectural design guidelines of the Town of Eagle Mountain, Utah. In the case of conflict between the design standards of The Town of Eagle Mountain and the decisions of the Committee or the provisions of this instrument, the design standards of the Town shall prevail.

SECTION 9.05. Committee Meetings. The Committee shall meet from time to time as necessary to perform its duties hereunder. The Committee may from time to time by resolution, unanimously adopted in writing, designate one of its members to take any action or perform any duties for and on behalf of the Committee. In the absence of such designation, the vote of a majority of all of the members of the Committee, or the written consent of a majority of all of the members of the Committee taken without a meeting, shall constitute an act of the Committee.

SECTION 9.06. Waiver of Consent. The approval or consent of the Committee to any Plans or Specifications for any work done or proposed or in connection with any other matter requiring the approval or consent of the Committee, shall not be deemed to constitute a waiver of any right to withhold approval or consent as to any Plans or Specifications or other matter whatever subsequently or additionally submitted for approval or consent by the same or a different person.

SECTION 9.07. Compensation. The members of the Committee shall be entitled to reasonable compensation from the Association for services rendered, together with reimbursement for expenses incurred by them in the performance of their duties hereunder.

SECTION 9.08.

A. Completed Work. Inspection of completed work and correction of defects therein shall proceed as follows:

- (i) Upon the completion of any improvement for which approved Plans or Specifications are required under this Declaration, the Owner shall give written notice of completion to the Committee.
- (ii) Within such reasonable time as the Committee may set but not to exceed fifteen (15) days thereafter, the Committee or its duly authorized representative may inspect such improvement. If the Committee finds that such work was not done in strict compliance with all approved Plans and Specifications submitted or required to be submitted for its prior approval, it shall notify the Owner in writing of such noncompliance within such period, specifying in reasonable detail the particulars of noncompliance, and shall require the Owner to remedy the same.
- (iii) If upon the expiration of thirty (30) days from the date of such notification the Owner shall have failed to remedy such noncompliance, the Committee shall notify the Board

in writing of such failure. Upon Notice and Hearing, the Board shall determine whether there is a noncompliance, and if so, the nature thereof and the estimated cost of correcting or removing the same. If noncompliance exists, the Owner shall remedy or remove the same within a period of not more than forty-five (45) days from the date of announcement of the Board ruling. If the Owner does not comply with the Board's ruling within such period, the Board at its option, may either remove the non-complying improvement or remedy the noncompliance, and the Owner shall reimburse the Association upon demand for all expenses incurred in connection therewith. If such expenses are not promptly repaid by the Owner to the Association, the Board shall levy an assessment against such Owner and the Improvement in question and the Lot upon which the same is situated for reimbursement, and the same shall constitute a lien upon such land and improvement and be enforced as provided in this Declaration.

(iv) If for any reason after receipt of said written notice of completion from the Owner the Committee fails to notify the Owner of any noncompliance with the period provided above in subparagraph (ii) of Section 9.08, the improvement shall be deemed to be in accordance with said approved Plans and Specifications.

B. Work in Progress. The Committee may inspect all work in progress and give notice of noncompliance as provided above in subparagraph (ii) of Section 9.08. If the Owner denies that such noncompliance exists, the procedure set out in subparagraph (iii) of Section 9.08 shall be followed, except that no further work shall be done, pending resolution of the dispute, which would hamper correction of the noncompliance if the Board shall find that such noncompliance exists.

SECTION 9.09. Non-liability of Committee Members. Neither the Committee nor any member thereof nor the Board nor any member thereof shall be liable to the Association or to any owner or to any other person for any loss, damage or injury arising out of or in any way connected with the performance of the Committee's or the Board's respective duties under this Declaration unless due to the willful misconduct or bad faith of the Committee or its members or the Board or its members, as the case may be. The Committee shall take into consideration the aesthetic aspects of the architectural designs, placement of buildings, landscaping, color schemes, exterior finished and materials and similar features, but shall not be responsible for reviewing, nor shall its approval of any Plans and Specifications be deemed approved thereof from the standpoint of structural safety, engineering soundness, or conformance with building or other codes.

ARTICLE X

THE RANCHES MASTER HOMEOWNER'S ASSOCIATION

SECTION 11.01. Creation of the Lien and Personal Obligation of Assessments. Each Owner of any Lot written by acceptance of a deed therefore, whether or not it shall be so expressed in any such deed or other conveyance, is deemed to covenant and agree to pay to the Association:

- A. Annual assessments or charges; and
- B. Special assessments for capital improvements, such assessments to be fixed, established and collected from time to time as hereinafter provided.

The annual and special assessments, together with such interest thereon and costs of collection thereof, as hereinafter provided, shall be a charge on the land and shall be a continuing lien upon the

property against which each such assessment is made. Each such assessment together with such interest, costs and reasonable attorney's fees, shall be a lien on such Lot and shall also be the personal obligation of the owner of such Lot, provided, however, that the personal obligation for delinquent assessments shall not pass to such Owner's successors in title unless expressly assumed by them.

SECTION 11.02. Purpose of Assessments. The assessments levied by the Association through its Board of Trustees shall be used exclusively for the purpose of promoting the recreation, health, safety and welfare of the residents in Rockwell Village at Redhawk Ranch, and in particular, for the services and facilities devoted to this purpose and related to the use and enjoyment of any open space or easements within Rockwell Village at Redhawk Ranch owned by the Association, and further, for the purpose of repairing, reconstructing, replacing and maintaining private roads, and ways, footpaths, utilities, landscaping, recreational facilities, if any, and any such other maintenance or improvement obligations which may be deemed necessary for the common benefit of the Owners and the maintenance of property values of which may be incurred by virtue of agreement with or requirement of the County or other governmental authorities. The assessments shall further be used to provide adequate insurance of any and all types and amounts deemed necessary by the Board and to provide such reserves as may be deemed necessary in order to accomplish the objects and purposes of the Association. A portion of the annual assessments shall further be used to provide a reserve fund for the replacement and maintenance of the common areas and the Board shall be obligated to establish such reserve fund.

SECTION 11.03. Basis and Payment of Annual Assessments.

- A. The annual assessments with respect to each Lot shall be estimated by the Board prior to the conveyance of the first Lot and shall be payable in advance in annual installments, or in such other installments as the Board may determine.
- (i) From and after January 1 of the year immediately following the conveyance of the first Lot to an Owner other than Declarant, the maximum annual assessment shall be adjusted in conformance with the Consumer Price Index (CPI) published by the U.S. Department of Labor, specifically the Consumer Price Index for Urban Wage Earners and Clerical Workers, U.S. City Average, All Items unadjusted for seasonal variation. The maximum monthly assessment for any year shall be the amount determined by:
 - (a) Taking the dollar amount specified above;
 - (b) Multiplying that amount by the published CPI number for the second month prior to the beginning of the subject year; and
 - (c) Dividing that resultant by the published CPI number for the month in which this Declaration was recorded.
 - (i) From and after January 1 of the year immediately following the conveyance of the first Lot to an Owner, other than Declarant, the maximum annual assessment may be increased above the amount computed in accordance with the provisions of (i) above, by a vote of sixty-six and two-thirds percent (66 2/3%) of each class of members who are voting in person or by proxy, at a meeting duly called for such purpose;
 - (ii) The Board of Trustees may fix the annual assessment at any amount not in excess of the maximum.
- B. Annual assessments shall be payable on or before the 10th day of the first month of each calendar year or within ten (10) days of the first day of the first month of any other assessment period adopted by the Association's Board. Written notice of the annual assessment shall be sent to every Owner immediately following the assessment date. The Association shall upon demand of any Owner, prospective purchaser, mortgagees and prospective mortgagees furnish

a certificate in writing signed by an officer of the Association setting forth whether the assessments on a specified Lot have been paid. A reasonable charge may be made by the Board for the issuance of these certificates. Such certificate shall be conclusive evidence of payment of any assessment therein stated to have been paid.

SECTION 11.04. Special Assessments for Capital Improvements. In addition to the annual assessments authorized above, the Association may levy, in any assessment year, a special assessment applicable to that year only for the purpose of defraying, in whole or in part, the cost of any reconstruction, repair or replacement of a capital improvement which is situated upon any open space or easement owned by the Association, including the fixtures and personal property related thereto, provided, that any such assessment shall have the assent of sixty-six and two-thirds percent (66 2/3%) of the votes for class A members.

SECTION 11.05. Date of Commencement of Actual Assessments; Due Dates. The annual assessments provided for herein shall commence on the first day of the calendar month following the conveyance of the first Lot to an Owner. The first annual assessment shall be adjusted according to the number of months remaining in the calendar year. The Board shall fix the amount of the annual assessment against each Lot at least thirty (30) days in advance of each annual assessment period. Written notice of the annual assessment shall be sent to every Owner subject thereto.

SECTION 11.06. Effect of Nonpayment of Assessments Remedies of the Association. Any annual or special assessment which is not paid when due shall be delinquent. If the assessment is not paid within fifteen (15) days after the due date, the assessment shall bear interest from the date of delinquency at the rate of twelve percent (12%) per annum and carry a late fee of thirty percent (30%) of the amount due for each month of delinquency. The Association may bring an action at law against the Owner personally obligated to pay the delinquent installments, or foreclose the lien against the Owner's Lot. No Owner may waive or otherwise escape liability for the assessments provided for herein by non-use of Common Area amenities or his Lot or abandonment of his Lot.

SECTION 11.07. Subordination of the Lien to Mortgages. The lien of the assessments provided for herein shall be subordinate to the lien of any first mortgage or deed of trust. Sale or transfer of any Lot shall not affect the assessment lien. However, the sale or transfer of any Lot as a result of court foreclosure of a first mortgage, foreclosure through the Public Trustee, or any proceeding in lieu of foreclosure, shall extinguish the lien of such assessments as to payments thereof which become due prior to the time such first mortgagee acquires title, but shall not relieve any former Owner of personal liability therefor. No sale or transfer shall relieve such Lot from liability for any assessments becoming due after such first mortgagee acquires title.

SECTION 11.08. Notice to Mortgagee. Upon request of a mortgagee, and upon receipt by the Association of a reasonable fee not to exceed Ten Dollars (\$10.00) for such service, the Association shall report to the mortgagee of a Lot any unpaid assessments or other defaults under the terms hereof which are not cured by said mortgagee's mortgagor within thirty (30) days; provided, however, that a mortgagee shall have furnished to the Association notice of its encumbrance.

ARTICLE XI**ENFORCEMENT AND NONWAIVER**

SECTION 12.01. Right of Enforcement. Except as otherwise provided herein, any Owner of any Lot which is subject to this Declaration, regardless of when t became so subject, at Owner's own expense, Declarant, and the Board shall have the right to enforce all of the provisions of this Declaration against any other Lot which is subject to the Declaration. Such rights shall apply regardless of when the Lot became subject to the Declaration and regardless of the Owners thereof. Such right of enforcement shall include both damages for and injunctive relief against the breach of any such provision.

SECTION 12.02. Violation a Nuisance. Every act or omission whereby any provision of this Declaration is violated in whole or in part is hereby declared to be a nuisance and may be enjoined or abated by any Owner at his own expense, Declarant, and the Board, whether or not the relief sought is for negative or affirmative action. However, only Declarant, the Board, and the duly authorized agent of either of them may enforce by self-help any of the provisions of this Declaration and then only if such self-help is preceded by reasonable notice to the owner in violation.

SECTION 12.03. Violation of Law. Any violation of any federal, state or local law, resolution or regulation pertaining to the ownership, occupancy or use of any property subject hereto is declared to be a violation of this Declarations and subject to all of the enforcement provisions set forth herein.

SECTION 12.04. Enforcement in Small Claims Court. The Association may enforce any fine or delinquent Assessment levied or assessed under this Declaration and any late payment charge attributable thereto, and any interest thereon and the cost of collecting the same under the terms and provisions of any legislation with respect to a "small claims court" as may exist from time to time. The Association may also bring any action at law or equity in any other court available to it under the statutes of the State of Utah for enforcement of any provision of this Declaration.

SECTION 12.05 Remedies Cumulative. Each remedy provided by this Declaration is cumulative and not exclusive.

SECTION 12.06. Nonwaiver. The failure to enforce any provision of this Declaration at any time shall not constitute a waiver of the right thereafter to enforce any such provision or any other provision hereof.

ARTICLE XII

ENT 20263 BK 4981 PG 869

MORTGAGEE PROTECTION

SECTION 13.01. Rights of First Mortgagee of the Lot. The First Mortgagees of any Lot may, jointly or severally, pay taxes or other charges which are in default and which may or have become a charge against any real or personal property owned by or held as easements by the Association and may pay all the due premiums on hazard insurance policies or secure new hazard insurance coverage on any such property and any such First Mortgagee making such payments shall be owed immediate reimbursement therefore from the Association.

SECTION 13.02. Professional Management. Any agreement for professional management entered into by the Association or any other contract providing for services of Declarant or any other developer of the project may not exceed five (5) years in term. Any such agreement must provide for termination by either party to such agreement with or without cause and without payment of a termination fee on ninety (90) days or less written notice.

ARTICLE XIII

MISCELLANEOUS

SECTION 14.01. Term. This Declaration as the same may be amended from time to time hereafter, including all of the covenants, conditions and restrictions hereof, shall run until December 31, 2020, this Declaration, including all such covenants, conditions and restrictions shall be automatically extended for successive periods of ten years each, unless amended or extinguished by a written instrument executed by the owners of at least seventy-five percent (75%) of the Lots then in Rockwell Village at Redhawk Ranch and recorded in the Utah County real property records.

SECTION 14.02. Mortgage Protection. Notwithstanding any provision of this Declaration, no lien arising by reason of the breach of or the enforcement of any provision of this Declaration shall defeat or render invalid the rights of the Beneficiary under any recorded Mortgage or Deed of Trust of first and senior priority now or hereafter upon a Lot made in good faith and for value. However, after the foreclosure of any such first Mortgage or Deed shall remain subject to this Declaration and shall be liable for all Assessments levied subsequent to such foreclosure or conveyance, and all installments of Assessments levied prior to completion of such foreclosure or before such conveyance but falling due after such completion or such conveyance.

SECTION 14.03. Amendment.

A. Special Provisions. No amendment of Section 14.02 shall be effective as to any Mortgagee who does not join in the execution thereof, provided that his Mortgage or Deed of Trust is recorded in the real property records of Utah County prior to the recordation of such amendment; provided however, that after foreclosure or conveyance in lieu of foreclosure the property which was subject to such Mortgage or Deed of Trust, shall be subject to such

amendment. No amendment of this Declaration shall be effective until executed and recorded in the real property records of Utah County in the manner hereinafter provided.

- B. By Declarant.** Except as provided in Section 14.03 A, this Declaration may be amended only by Declarant during the period of Declarant control. If Declarant wishes to amend this Declaration, it shall first give at least ten (10) days written notice to each Owner of a Lot then subject thereto of the time and place of a hearing to be held to consider such amendment. Such notice may be given in person or by mail. If such notice is given by mail, the effective date thereof shall be the third (3) day (other than a Saturday, Sunday or legal holiday) after such notice shall have been deposited in the United States mail, postage prepaid, and addressed to such owner at this address as then shown on the records of the Association, or to the residence of such Owner in Rockwell Village at Redhawk Ranch if his address has not been given to the Association. If the Owners of seventy-five percent (75%) or more of the Lots which on the date of such hearing were subject to this Declaration, by written notice delivered to Declarant within fifteen (15) days after such hearing object to the amendment proposed by Declarant it shall not become effective. No amendment shall be effective until there has been recorded, in the real property records of Utah County, an instrument executed and acknowledged by Declarant setting forth the amendment and certifying that the above mentioned notice and hearing was given and held and that Declarant did not within twenty-five (25) days after said hearing receive written objections to the amendment from the Owners of seventy-five percent (75%) or more of said Lots, as aforesaid.
- C. By Owners.** Except as provided in Sections 14.03 A and 14.03 B, this Declaration may be amended by the recording in the Utah County real property records of an instrument executed and acknowledged by the Owners of at least seventy-five percent (75%) of the Lots subject to this Declaration at the time of the amendment.
- D. Common Owners.** For purposes of Sections 14.03 B and 14.03 C above, if title to any Lot is held jointly or in common by more than one Person, the vote with respect to said Lot shall be held in the same manner. However, neither fractional votes nor split votes shall be allowed, and all joint or common Owners must object in writing to the proposed amendment under Section 14.03 B, or approve in writing the proposed amendment under Section 14.03 C, as the case may be, or the vote with respect to such Lot shall not be counted.
- E. Town of Eagle Mountain.** The provisions of this Declaration concerning enforcement by the Town of Eagle Mountain of architectural guidelines, building and zoning ordinances and codes may not be amended without the express written consent of the Town of Eagle Mountain.

SECTION 14.04. Interpretation. The Provisions of this Declaration shall be liberally construed to effectuate their purposes of creating a uniform plan for the development of the Lots subject hereto and of promoting and effectuating the fundamental concepts of Rockwell Village at Redhawk Ranch has set forth in the RECITALS and DECLARATION of this Declaration. This Declaration shall be construed and governed under laws of the State of Utah.

SECTION 14.05. Construction.

- A. **Restrictions Severable.** Notwithstanding the provisions of the foregoing Section 14.04 each of the provisions of this Declaration shall be deemed independent and Severable, and the invalidity or partial invalidity of any provision or portion thereof shall not affect the validity or enforceability of any other provision.
- B. **Singular Includes Plural.** Unless the context requires a contrary construction, the singular shall include the plural, and the plural the singular, and the masculine, feminine or neuter shall each include the masculine, feminine and neuter.
- C. **Captions.** All captions and titles used in this Declaration are intended solely for convenience of reference and shall not enlarge limit or otherwise affect that which is set forth in any paragraph, section or article hereof.

IN WITNESS WHEREOF, Declarant has executed this Declaration the day and year first above written.

The Ranches, L.C.

By 

SCOTT F. KIRKLAND, MANAGING MEMBER

ATTEST

STATE OF UTAH)
 ss.)
COUNTY OF UTAH)

The foregoing instrument was subscribed and sworn to before me this 11th day of February 1998, by SCOTT F. KIRKLAND of The Ranches, LLC.

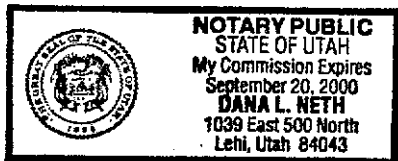

Notary Public

My commission expires: SEPTEMBER 20, 2000

EXHIBIT A

BOUNDARY DESCRIPTION

COMMENCING AT A POINT WHICH IS N89°18'39"W 705.76' ALONG SECTION LINE AND SOUTH 788.65' FROM THE N.W. COR. SEC. 29, T.55, R.1W,

SALT LAKE BASE & MERIDIAN; THENCE AS FOLLOWS:

COURSE	DISTANCE	REMARKS
$\Delta: 90^{\circ}00'00''$	R=15.00' L=23.56'	ALONG THE ARC (CO= N23°48'54"W-21.21'); THENCE
S68°48'54"E	310.00	FEET; THENCE ALONG THE ARC
$\Delta: 90^{\circ}00'00''$	R=15.00' L=23.56'	(CO= S23°48'54"E-21.21'); THENCE
S68°48'54"E	60.00	FEET; THENCE
S21°11'06"W	302.80	FEET; THENCE ALONG THE ARC
$\Delta: 90^{\circ}00'00''$	R=15.00' L=23.56'	(CO= S23°48'54"E-21.21'); THENCE
S68°48'54"E	85.00	FEET; THENCE
S21°11'06"W	117.38	" "
S41°16'13"W	118.20	" "
S62°45'41"W	132.14	" "
N76°06'37"W	14.17	" "
N31°12'38"W	90.00	FEET; THENCE ALONG THE ARC
$\Delta: 1^{\circ}03'18''$	R=278' L=17.86'	(CO= S58°08'47"W-17.86'); THENCE
S32°23'53"E	90.00	FEET; THENCE
S12°37'14"W	14.18	" "
S52°11'47"W	224.71	" "
S64°47'19"W	115.23	" "
N83°48'08"W	166.52	" "
N71°19'40"W	301.73	FEET; THENCE ALONG THE ARC
$\Delta: 11^{\circ}13'23''$	R=803' L=157.29'	(CO= N24°17'02"E-157.04') THEN
N18°46'20"E	339.00	FEET; THENCE
S28°59'34"E	17.64	FEET; THENCE ALONG THE ARC
$\Delta: 28^{\circ}03'17''$	R=50' L=76.84'	(CO= S74°57'45"E-69.50'); THENCE ALONG THE ARC
$\Delta: 48^{\circ}13'11''$	R=50' L=42.08'	(CO= S55°02'52"E-44.85'); THENCE ALONG THE ARC
$\Delta: 42^{\circ}03'46''$	R=175' L=128.42'	(CO= N79°49'09"E-125.86'); THENCE
N58°27'46"E	166.92	FEET; THENCE ALONG THE ARC
$\Delta: 37^{\circ}38'40''$	R=17500' L=114.88'	(CO= N33°52'26"E-112.83'); THENCE
N21°11'06"E	285.14	FEET TO THE POINT OF BEGINNING.
		CONTAINS 12.3348 ACRES (36 LOTS)

BASIS OF BEARING: STATE PLANE COORDINATE SYSTEM

FEB 4 1999
DATE

David Thomas
SURVEYOR (SEE SEAL BELOW)

EXHIBIT B MAILBOX STANDARD

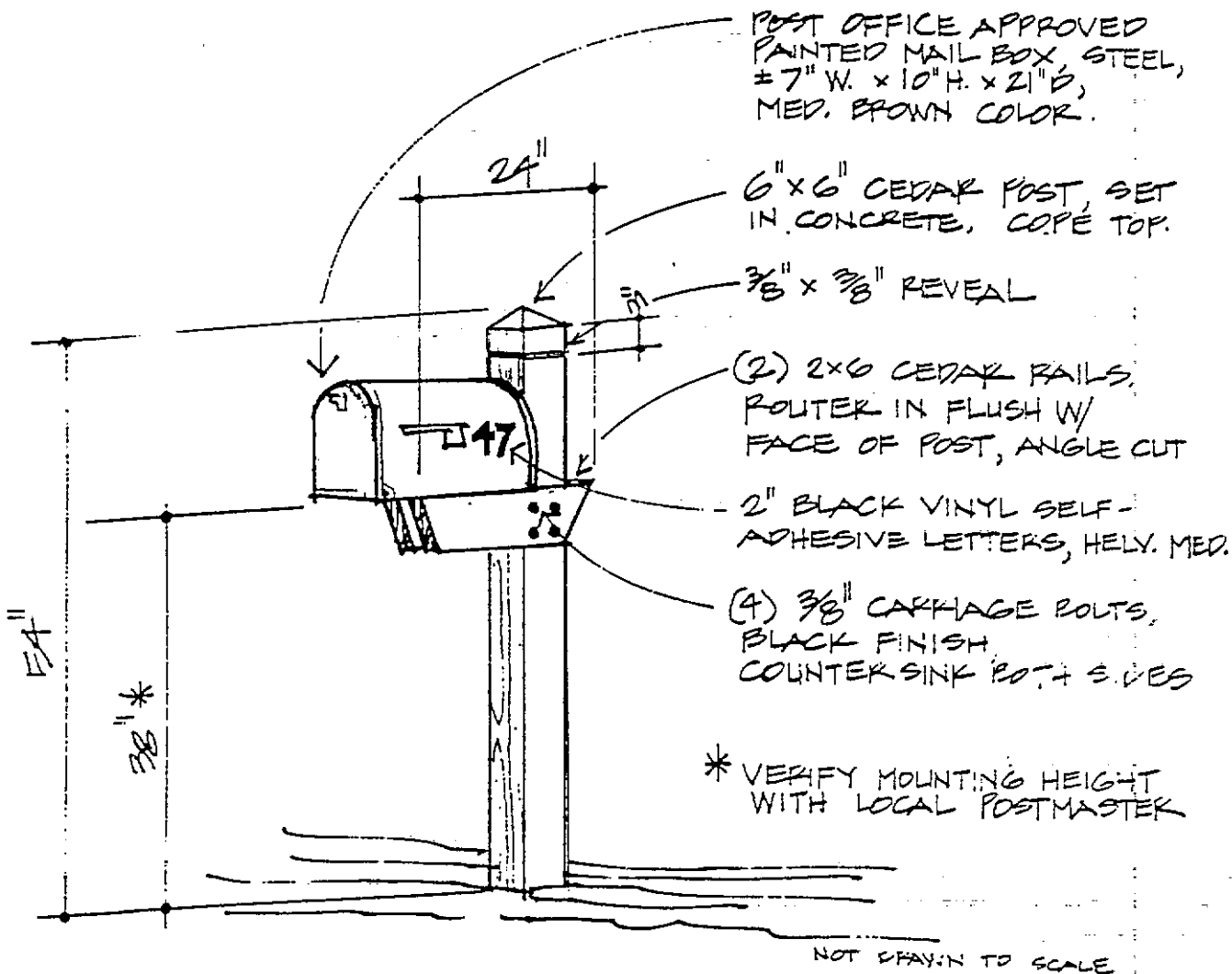
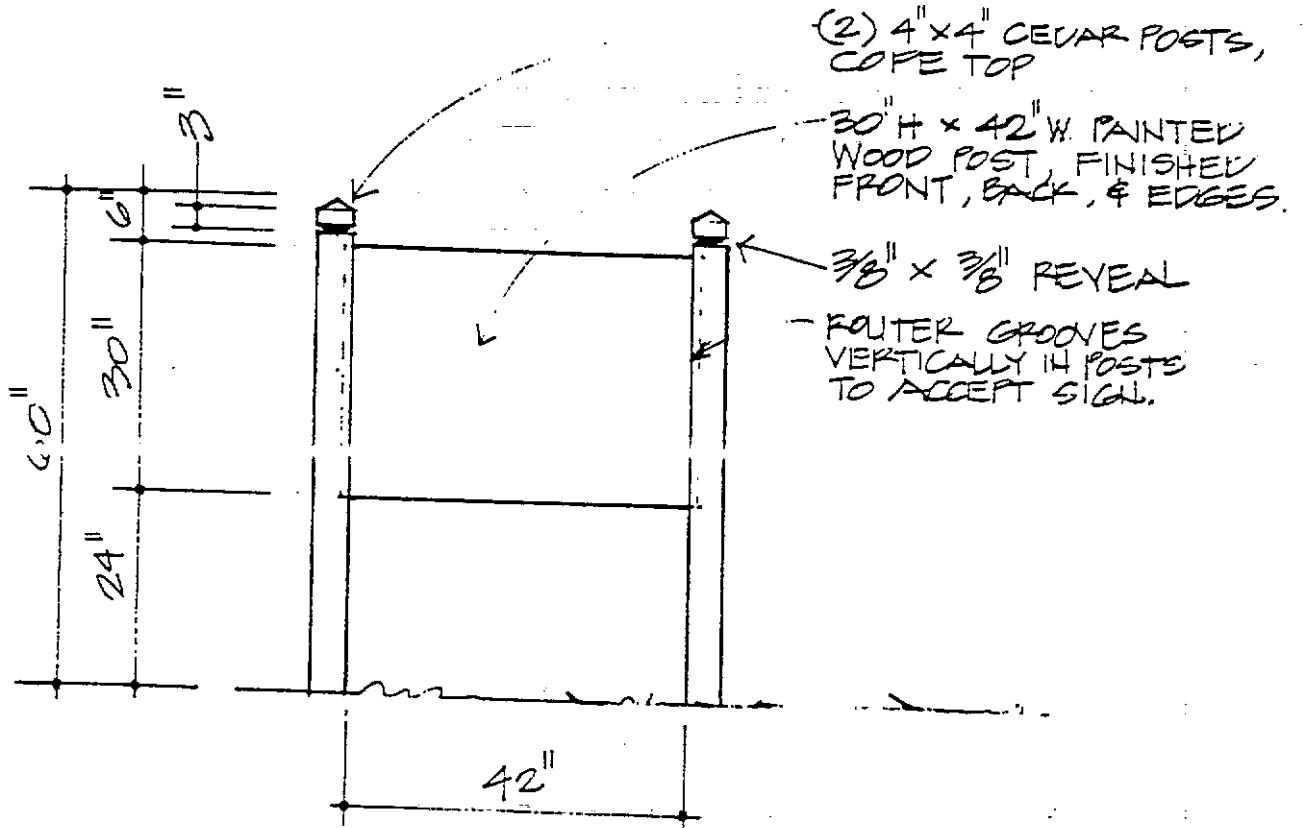

EXHIBIT C

FOR SALE/LEASE SIGN



SCALE: 1/2" = 1'-0"