

MAIL TO:
LEHI CITY

ENT.F. 20416:2004 PG 1 of 50
RANDALL A. COVINGTON
UTAH COUNTY RECORDER
2004 Mar 18 11:31 am FEE 0.00 BY SDM
RECORDED FOR LEHI CITY CORPORATION

**DEVELOPMENT AGREEMENT
PHEASANT POINTE NORTH, PLAT "A"
A PLANNED UNIT DEVELOPMENT PROJECT**

This Development Agreement is entered into as of this 16th day of March, 2004, by and among the owners and developers of the Pheasant Pointe North, Plat A, a Planned Unit Development, (hereinafter "Developer") and Lehi City Corporation (the "City") as it relates to the development of a residential subdivision of real property within the corporate Limits of Lehi City, Utah County, Utah.

RECITALS

Whereas, the Developer has sought approval of a 45 lot residential Planned Unit Development Project designated as Pheasant Pointe North, Plat A, a copy of which is attached hereto as Exhibit A; and,

Whereas, the City Council has authorized the negotiation and adoption of Development Agreements under appropriate circumstances where the proposed development contains various features which advance the policies, goals and objectives of the City's General Land Use Plan, Capital Improvements Plan, Parks and Open Space Plan, and other land use objectives as well as the Capital Improvements Plan; and

Whereas, the developer is willing to modify the design of the project and voluntarily agrees to provide common area/open space for the preservation of natural areas, parks and related purposes and other recreational facilities in order to promote the policies, goals and objectives of the City; and

Whereas, the City acting pursuant to its authority under Chapter 9 of Title 10 of the Utah Code, and in furtherance of its land use policies, goals, objectives, ordinances,

resolutions, and regulations has made certain determinations with respect to the density of the Planned Unit Development Project of Pheasant Pointe North, and in the exercise of its legislative discretion, has elected to approve this Development Agreement.

Now therefore, in consideration of the mutual covenants, conditions and considerations as more fully set forth below, the Developer and the City hereby agree as follows:

1. The Developer shall create and approve restrictive covenants for the subject Planned Unit Development project which shall be approved by the City and shall be incorporated herein by reference and recorded together with this Development Agreement and the subject subdivision plat. Said restrictive covenants shall not be amended unless the proposed amendment is approved by Lehi City. The City shall be considered a beneficiary of said restrictive covenants and is hereby authorized to enforce the terms and provisions of the covenants through whatever means available and to the extent determined appropriate by the City. However, this agreement shall not be construed as placing a responsibility upon the City to enforce any of the restrictive covenants or requirements contained therein. Such enforcement shall be at the sole discretion of the City. (Exhibit B)

2. Developer has provided the required open space for the project. Lot 45 (1.17 acres) of Pheasant Pointe North is open space which is owned and maintained by the Homeowners' Association. Developer increased the size of the Open Space to also allow a 15,250 cf storm water detention basin on this lot. (Exhibit A).

3. Developer shall provide landscaping as per attached Exhibit C. Landscaped areas will include the open space area (lot 45), the public right-of-way and the 3' landscape

easement along 1200 West and 3200 North. These areas will be maintained by the Homeowners' Association. The Association will be responsible for payment of pressurized irrigation water serving all areas under its maintenance.

5. As a condition of building permit approval, a fee of \$2,500 will be collected by Lehi City as a bond to cover front yard landscaping costs at the time each building permit is purchased. This fee will be refunded to the purchaser of the permit when landscaping is completed and has been inspected by Lehi City.

6. Amenities for the open space area (lot 45) shall include landscaping and shade trees, a pavilion with at least 4 picnic tables, modular playground equipment, swings, benches and a walking trail through the park connecting the entrance on 3175 North and the entrance on 1300 West. (Exhibit D)

7. Developer shall install a 6 foot no-climb agricultural fence with 1-7/8" schedule 40 or equal posts and a 1-5/16" schedule 40 or equal top rail on the north property line between 3200 North and the Earl Lelegren property. A wrought iron fence with masonry columns spaced at 40 foot intervals shall be installed by Developer along 1200 West and 3200 North as per Lehi City Design Standards and as shown on Exhibit A. The Home Owner's Association shall be responsible for the maintenance of these fences.

8. All exterior building materials within Pheasant Pointe North, Plat A, shall consist of at least 70% brick, stucco, rock or stone or a combination of these materials. Roof lines must be kept at a minimum 5-12 pitch. Complete Design Guidelines for Pheasant Pointe North are included in the CC&R's (Exhibit B.)

9. Homes of the same elevation or a mirror image elevation will not be constructed on adjacent lots or across the street from each other. Typical elevations are attached as

Exhibit E.

10. Developer agrees to provide notification to all purchasers of the provisions of the Right to Farm chapter of the Lehi City Development Code as it relates to agricultural uses in the area such that all subsequent property owners and purchasers of building lots will be aware of the nature of the farming operations on surrounding properties and the intent to continue present agricultural operations. All individual lot buyers will be notified of the existing agricultural uses in the surrounding area with the following statements which will be included in the closing documents of the sale as well as on the recorded subdivision plat:

“This area is subject to the normal, everyday sounds, odors, sites, equipment, facilities, and any other aspects associated with an agricultural lifestyle. Future residents should also recognize the risks inherent with livestock.”

11. Developer expressly acknowledges and agrees that nothing in this Development Agreement shall be deemed to relieve the developer from the obligation to comply with all applicable requirements of the City necessary for approval and recordation of subdivision plats and site plans for the project, including the payment of fees in compliance with all other applicable ordinances, resolutions, regulations, policies and procedures of the City including but not limited to the City’s Development Code Ordinances and Design Standards and Public Improvement Specifications.

12. This Development Agreement shall be recorded against the property as described in Exhibit A hereto and shall be deemed to run with the land and shall be binding on all successors and assigns of the developer in the ownership or development of any portion of the property.

13. Neither this Development Agreement nor any provisions, terms, or conditions hereof can be assigned to any other party, individual or entity without assigning the rights as well as the responsibilities under this Development Agreement and without the prior written consent of the City, which shall not be unreasonably withheld. This requirement shall not apply to the sale of approved and platted lots within the subject subdivision.

14. This Development shall not create any joint venture, partnership, undertaking or business arrangement between the parties hereto, nor any rights or benefits to third parties.

15. If this Development Agreement or any of the exhibits hereto are breached, the party at fault agrees to pay attorney's fees and all costs of enforcement of the non-breaching party.

DATED: 3/10/04

Pheasant Pointe North, Plat A

~~by~~ Rozhelle Investments, LLC.

by: [Signature]

Its: [Signature]

DAVID C. CLARK, MANAGER

By: _____

Its: _____

ACKNOWLEDGMENT

STATE OF UTAH

S.S.

COUNTY OF UTAH

On the 10 day of March 2004, personally appeared before me David C. Clark, the signer(s) of the foregoing document who duly acknowledged to me that he/she/they did execute the same.

My Commission Expires: Sept 3, 2006 Lara Amakom
NOTARY PUBLIC

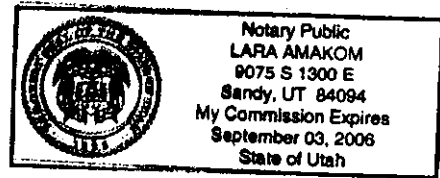

DATED: 3/16/04



Lehi City Corporation

By: [Signature]
Kenneth J. Greenwood, Mayor

Attest:

[Signature]
Connie Ashton, City Recorder

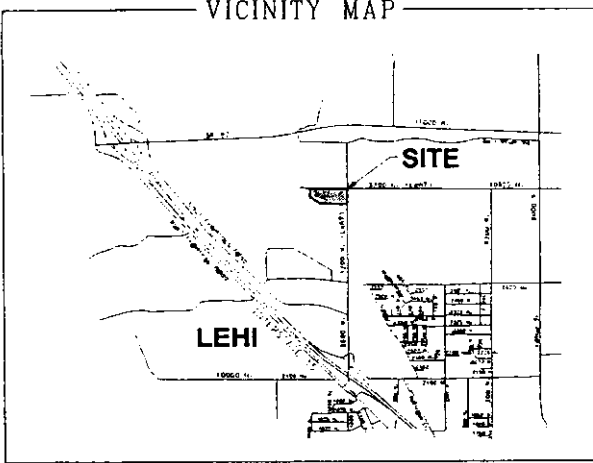

EARL LEHIGH COUNTY

CURVE TABLE					
CURVE	RADIUS	DELTA	LENGTH	CHORD	
C1	26.00	89°57'35"	40.82	544°58'48"E	36.76
C2	26.00	90°02'25"	40.85	N45°01'12"E	36.78
C3	15.00	89°57'35"	23.55	N44°58'48"W	21.21
C4	61.00	17°04'02"	18.17	S8°27'24"E	18.10
C5	61.00	31°08'09"	33.15	S32°33'28"E	32.74
C6	61.00	31°02'59"	33.06	S63°39'03"E	32.65
C7	61.00	53°45'22"	55.23	N73°58'47"E	55.16
C8	61.00	21°20'35"	22.72	N36°23'47"E	22.59
C9	61.00	154°21'08"	164.53	S77°05'56"E	118.96
C10	15.00	64°18'55"	18.84	N57°52'57"E	15.97
C11	1028.00	2°17'47"	41.20	N88°53'32"E	41.20
C12	1028.00	0°35'01"	11.67	N87°25'08"E	11.67
C13	1028.00	2°56'48"	52.87	N88°34'01"E	52.86
C14	1000.00	2°56'48"	51.43	S88°34'01"W	51.42
C15	972.00	1°28'26"	25.00	N69°18'12"E	25.00
C16	972.00	1°28'22"	24.99	N87°49'48"E	24.99
C17	972.00	2°56'48"	49.90	N88°34'01"E	49.88
C18	1028.00	1°28'23"	26.43	N87°49'48"E	26.43
C19	1028.00	1°28'28"	26.44	N89°18'12"E	26.44
C20	1000.00	2°56'48"	51.43	S88°34'01"W	51.42
C21	972.00	1°54'44"	32.44	N88°02'59"E	32.44
C22	15.00	87°48'03"	22.99	S47°05'37"E	20.80
C23	328.00	8°42'28"	49.85	S7°32'48"E	49.80
C24	300.00	11°54'01"	62.31	S5°57'01"E	62.20
C25	272.00	7°39'29"	36.36	S8°04'18"E	36.33
C26	15.00	94°16'57"	24.68	S42°53'57"W	21.99
C27	272.00	5°10'06"	24.54	S9°18'57"E	24.53
C28	272.00	5°53'57"	28.00	S3°48'55"E	28.00
C29	272.00	11°04'03"	52.54	S6°21'58"E	52.48
C30	300.00	11°04'03"	57.95	S6°21'58"E	57.66
C31	328.00	4°44'28"	27.16	N81°12'16"W	27.15
C32	328.00	8°19'22"	36.20	N8°44'17"W	36.18
C33	328.00	11°04'03"	63.36	N6°21'58"W	63.28
C34	15.00	89°50'35"	23.52	S45°02'18"E	21.18
C35	15.00	29°28'58"	7.72	N75°17'28"E	7.83
C36	15.00	8°53'24"	2.59	N55°35'45"E	2.59
C37	15.00	39°23'23"	10.31	N70°20'44"E	10.11
C38	61.00	60°05'41"	84.27	N79°29'35"E	56.05
C39	61.00	32°58'38"	35.11	S55°10'33"E	34.63
C40	61.00	32°58'38"	35.11	S22°11'55"E	34.63
C41	61.00	51°16'11"	54.56	S19°55'30"W	52.78
C42	61.00	174°54'33"	186.22	N41°53'41"W	121.88
C43	15.00	27°15'09"	7.14	S31°58'01"W	7.07
C44	15.00	18°23'27"	4.82	S9°05'43"W	4.80
C45	15.00	45°40'35"	11.86	S22°43'18"W	11.64
C46	15.00	89°41'30"	23.48	S44°57'45"E	21.16
C47	15.00	33°57'20"	8.89	S16°51'40"W	8.76
C48	61.00	57°53'03"	61.63	S4°53'48"W	59.04
C49	61.00	35°53'57"	38.22	S41°59'41"E	37.60
C50	61.00	32°02'53"	34.12	S75°58'06"E	33.88
C51	61.00	31°43'40"	33.78	N72°08'37"E	33.35
C52	61.00	157°33'32"	167.75	N44°58'28"W	119.67
C53	15.00	33°54'43"	8.69	N73°14'09"E	8.75
C54	15.00	89°41'30"	48.53	S44°57'45"E	43.72
C55	31.00	90°18'30"	48.86	N45°02'15"E	43.96
C56	31.00	21°30'18"	11.84	N10°52'07"E	11.57
C57	31.00	68°30'16"	36.97	N55°47'27"W	34.82
C58	31.00	89°50'35"	48.61	S45°02'18"E	43.78
C59	1028.00	2°56'48"	52.87	N88°34'01"E	52.86

RECORD S&P 57'20" E 5.328 83
MEASURED S&P 57'35" E 5.329 10
36584 (1/4 SECTION LINE)

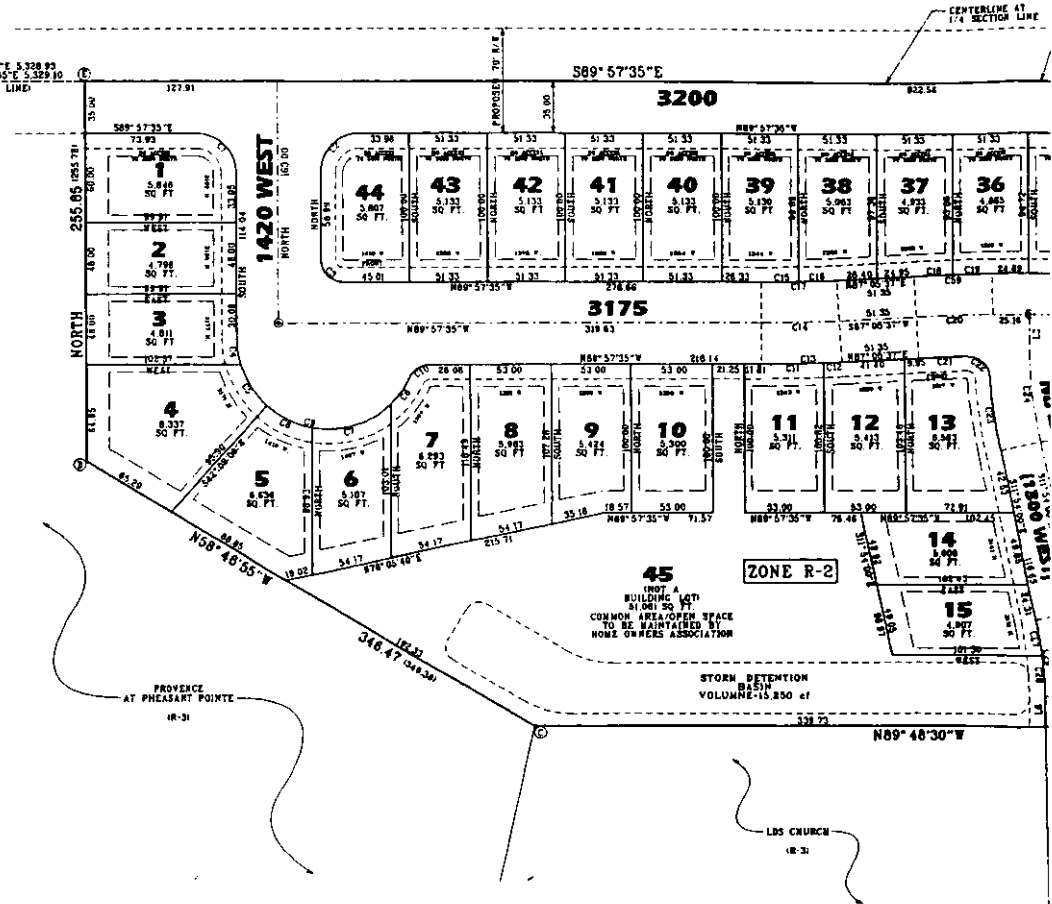

STATE PLAKE COORDINATES		
NORTHING	EASTING	
A	763.159.16	1,897,543.61
B	762.722.05	1,897,542.37
C	762.724.60	1,896,779.63
D	762.904.13	1,896,483.40
E	763.159.91	1,896,483.40

GRID FACTOR 0.99975

LINE TABLE		
LINE	BEARING	DISTANCE
L1	S88°48'30"E	7.90
L2	S89°57'35"E	10.03
L3	SOUTH	24.02
L4	S0°50'00"E	20.93
L5	S0°50'00"E	21.43
L6	S0°50'00"E	20.43

TABULATIONS	
ZONE	R2 (RESIDENTIAL)
TOTAL AREA	10.00 ACRES
# OF LOTS	45 LOTS
OPEN SPACE AREA	1.17 ACRES
ROAD AREA	3.44 ACRES
LANE MILES	0.49 MILES

NOTES

- THIS AREA IS SUBJECT TO THE NORMAL EVERYDAY SOUNDS, ODORS, VIBRATIONS, EQUIPMENT, FACILITIES, AND ANY OTHER ASPECTS ASSOCIATED WITH AGRICULTURAL LIFESTYLE. FUTURE RESIDENTS SHOULD ALSO RECOGNIZE THE RISKS INHERENT WITH LIVESTOCK.
- 10' PUBLIC UTILITY EASEMENT ALONG ALL ROADWAYS (AS SHOWN).
- FRONT BUILDING SETBACKS ARE 15'. SIDE SETBACKS ARE 5' ON CORNER LOTS, AND REAR SETBACKS ARE 15'.
- WROUGHT IRON FENCE WITH MASONRY COLUMNS @ 40' O.C. TO BE INSTALLED ALONG 1200 WEST & 3200 NORTH (AS PER LEHI CITY DESIGN STANDARDS).
- STORM DRAIN DETENTION CAPACITY IS 15,000 c.f.
- PERMANENT DETENTION FACILITY IS TO BE OWNED AND MAINTAINED BY THE OWNERS OF THIS PROPERTY AND NOT TO BE ALTERED WITHOUT APPROVAL BY LEHI CITY COUNCIL AND THE CITY ENGINEER.
- FRONT YARD LOT LANDSCAPING TO BE INCLUDED WITH BUILDING PERMIT.

LEGEND

- *5 REBAR * CAP TO BE SET AT ALL LOT CORNERS NAIL AND BRASS WASHER TO BE SET IN CUPB * PROTECTION OF SIDE LOT LINES
- © TYPE II ALUMINUM CAP AND REBAR MONUMENT TO BE SET



Consulting Engineers and Surveyors, Inc.
3302 No. Main St.
Spanish Fork, UT 84608

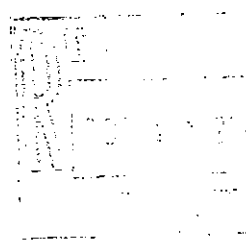
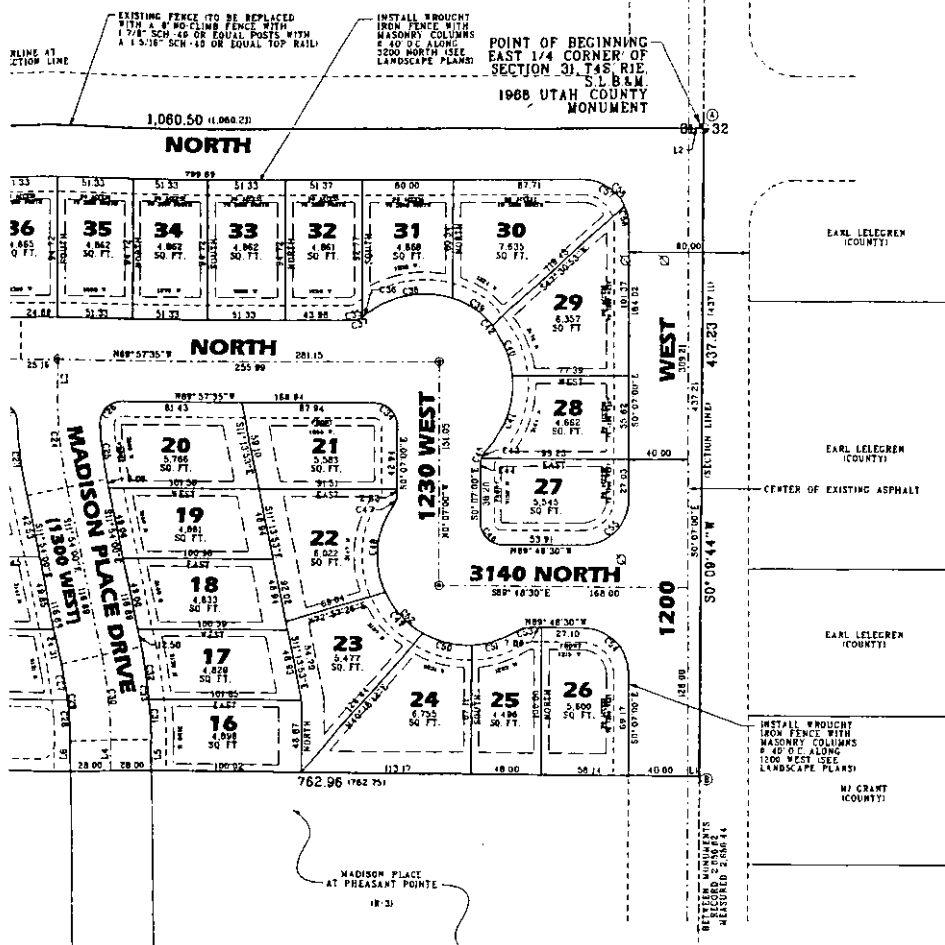
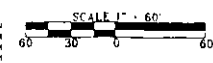

SURVEYOR'S CERTIFICATE

I, NATHAN H. PRICE DO HEREBY CERTIFY THAT I AM A REGISTERED LAND SURVEYOR AND THAT I HOLD CERTIFICATE NO. 354378 AS PRESCRIBED UNDER THE LAWS OF THE STATE OF UTAH. I FULLY CERTIFY BY AUTHORITY OF THE OWNERS I HAVE MADE A SURVEY OF THE TRACT OF LAND SHOWN ON THIS PLAT AND DESCRIBED BELOW, AND HAVE SUBDIVIDED SAID TRACT OF LAND INTO LOTS, BLOCKS, STREETS AND EASEMENTS AND THE SAME HAS BEEN CORRECTLY SURVEYED AND STAKED ON THE GROUND AS SHOWN ON THIS PLAT AND THAT THIS PLAT IS TRUE AND CORRECT.

BOUNDARY DESCRIPTION

BEGINNING AT THE EAST 1/4 CORNER OF SECTION 31, T4S, R1E, S.L.B.&M., THENCE AS FOLLOWS:

COURSE	DISTANCE	REMARKS
S0°09'44" W	437.23	ALONG THE SECTION LINE
N89°48'30" W	762.96	
S89°48'33" W	346.47	
NORTH	255.85	
S89°57'35" E	1,060.50	ALONG THE 1/4 SECTION LINE TO THE POINT OF BEGINNING
CONTAINS 10.00 ACRES		

BASIS OF BEARING ALONG SECTION LINE AS SHOWN

DATE _____ SURVEYOR _____
(See Seal Below)

OWNER'S DEDICATION

KNOW ALL MEN BY THESE PRESENTS THAT WE, ALL OF THE UNDERSIGNED OWNERS OF ALL OF THE PROPERTY DESCRIBED IN THE SURVEYOR'S CERTIFICATE HEREON AND SHOWN ON THIS MAP, HAVE CAUSED THE SAME TO BE SUBDIVIDED INTO LOTS, BLOCKS, STREETS AND EASEMENTS AND DO HEREBY DEDICATE THE STREETS AND OTHER PUBLIC AREAS AS INDICATED HEREON FOR PERPETUAL USE OF THE PUBLIC.

IN WITNESS WHEREOF WE HAVE HEREUNTO SET OUR HANDS THIS _____ DAY OF _____, A.D. 20____

Exhibit "A"

ACKNOWLEDGEMENT

STATE OF UTAH S.S.
COUNTY OF UTAH

ON THE _____ DAY OF _____, A.D. 20____, PERSONALLY APPEARED BEFORE ME THE SIGNERS OF THE FOREGOING DEDICATION WHO DULY ACKNOWLEDGE TO ME THAT THEY EXECUTE THE SAME.

MY COMMISSION EXPIRES _____ A NOTARY PUBLIC COMMISSIONED IN UTAH

NOTARY ADDRESS _____ PRINTED FULL NAME OF NOTARY _____

ACCEPTANCE BY LEGISLATIVE BODY

THE COUNTY OF UTAH APPROVES THIS SUBDIVISION AND HEREBY ACCEPTS THE DEDICATION OF ALL STREETS, EASEMENTS, AND OTHER PARCELS OF LAND INTENDED FOR PUBLIC PURPOSES FOR THE PERPETUAL USE OF THE PUBLIC THIS _____ DAY OF _____, A.D. 20____.

APPROVED BY MAYOR _____

APPROVED _____ ENGINEER (See Seal Below) ATTEST _____ CLERK-RECORDER (See Seal Below)

BOARD OF HEALTH

APPROVED SUBJECT TO THE FOLLOWING CONDITIONS _____

CITY-COUNTY HEALTH DEPARTMENT

PLANNING COMMISSION APPROVAL

APPROVED THIS _____ DAY OF _____, A.D. 20____, BY _____ PLANNING COMMISSION

DIRECTOR-SECRETARY _____ CHAIRMAN-PLANNING COMMISSION _____

PLAT "A"

PHEASANT POINTE NORTH

SUBDIVISION

LEHI

UTAH COUNTY, U.T.

SCALE 1" = 60 FEET

SURVEYOR'S SEAL	NOTARY PUBLIC SEAL	CITY-COUNTY ENGINEER SEAL	CLERK-RECORDER SEAL
-----------------	--------------------	---------------------------	---------------------

This form approved by Utah County and the municipalities therein

Exhibit "B"

ENT 30416:2004 PG 9 of 50

**DECLARATION OF PROTECTIVE COVENANTS
FOR
PHEASANT POINTE NORTH**

**A SUBDIVISION IN UTAH COUNTY
STATE OF UTAH**

**ROCHELLE INVESTMENTS, L.C.
DEVELOPER**

WHEN RECORDED RETURN TO:

*ROCHELLE INVESTMENTS, LC.,
9075 South 1300 East
Sandy, UT 84904*

1/6/2004

**DECLARATION OF PROTECTIVE COVENANTS
FOR
PHEASANT POINTE NORTH**

THIS DECLARATION OF PROTECTIVE COVENANTS FOR PHEASANT POINTE NORTH (the "Declaration"), dated for reference July 10, 2003, is executed by ROCHELLE INVESTMENTS, L.C., a Utah limited liability company, of 9075 South 1300 East, Sandy, Utah 84094 (the "Declarant").

RECITALS

A. Declarant, ROCHELLE INVESTMENTS, L.C. is the owner of certain real property located in Utah County, Utah, described more particularly on Exhibit "A" attached hereto and incorporated herein by this reference (the "Property").

B. Declarant, ROCHELLE INVESTMENTS, L.C. has subdivided the Property into Lots 1 through 44 of PHEASANT POINTE NORTH.

C. The Property is an area of unique natural beauty, featuring distinctive terrain.

D. By subjecting the Property to this Declaration, it is the desire, intent and purpose of Declarant to provide a general plan for development of the land, create a community in which beauty shall be substantially preserved, which will enhance the desirability of living on that real estate subject to this Declaration, and which will increase and preserve the attractiveness, quality and value of the lands and improvements therein.

PROTECTIVE COVENANTS, CONDITIONS AND RESTRICTIONS

Now, Therefore, for the reasons recited above, the Declarant hereby covenants, agrees, and declares that the Property shall be subject to the following covenants, conditions and restrictions:

1. **Definitions.** The following definitions shall apply to this Declaration:
 - a. "Architectural Review Committee" shall mean the person or persons appointed to review the designs, plans, specifications, homes, architecture, fencing, and landscaping within the Subdivision (the "ARC").
 - b. "Association" shall mean the Pheasant Pointe Single Family Home Owners' Association, an incorporated association consisting of the Members.

- c. "Board" shall mean the Board of Trustees of the Association consisting of three (3) members, as duly elected in accordance with the terms and conditions of the Bylaws of the Association.
- d. "Builder" shall mean an owner, Declarant or contractor who obtains a construction or occupancy permit for one or more Lots.
- e. "City" shall mean the City of Lehi.
- f. "Committee" shall mean the ARC.
- g. "Common Areas" shall mean and refer to that part of the Project which is not included with the Lots which is owned by the Association for the common use and enjoyment of the Members, together with all improvements thereon and all easements appurtenant thereto, including but not limited to private utility lines and personal property owned by the Association.
- h. "Design Guidelines" shall mean and refer to the Design Guidelines attached hereto as Exhibit "C" and incorporated herein by this reference.
- i. "Developer" shall mean and refer to ROCHELLE INVESTMENTS, L.C., a Utah limited liability company.
- j. "Dwelling" shall mean the detached single family residence, place of habitation, abode, or living unit constructed upon a Lot.
- k. "Entry" shall mean the entry way into the Subdivision.
- l. "Lot" or "Lots" shall mean the subdivided and recorded lot or lots within Property and where the context so requires any Dwelling constructed thereon.
- m. "Member" shall mean every person who holds membership in the Association.
- n. "Mortgage" shall mean any mortgage, deed of trust or trust deed or the act of encumbering any Lot or any property by a mortgage, trust deed, or deed of trust.
- o. "Mortgagee" shall mean any person named as a mortgagee of a mortgage or beneficiary under or holder of a deed or trust.

- p. "Pheasant Pointe North" shall mean and refer to this subdivision.
- q. "Owner" or "Owners" shall mean the record owner or owners of a fee simple title to any Lot, whether one or more natural persons or legal entities, and excluding those persons having such interest merely as security for the performance of an obligation.
- r. "Parking Pad" shall mean and refer to a cement or concrete, (or other construction material approved in writing by the ARC) parking pad constructed or installed on a Lot for the purpose of parking or storing of a Recreational, Commercial, or Oversized Vehicle.
- s. "Parking Pad Fence" shall mean and refer to the cinder block, vinyl or wood (or other construction material approved by the ARC in writing) fence surrounding the Parking Pad.
- t. "Park Strip Improvements" shall mean the wrought iron and stone column fence and landscape improvements on the street side of the fence for all of the frontage along 1200 West and 3200 North in the Project.
- u. "Period of Declarant's Control" shall mean and refer to a period of time commencing on the date this Declaration is recorded and terminating on the occurrence of last of the following Events: (1) Four months after 100% of the Dwellings constructed upon Lots owned by Declarants have been sold; or (2) Five years from the effective date of this Declaration; or (3) When in its sole discretion the Declarants so determines.
- v. "Person" shall unless otherwise indicated mean and refer to a natural person, corporation, partnership, trust, limited liability company, or other legal entity.
- w. "Plans and Specifications" shall mean and refer to any and all documents designed to guide or control the construction of an Improvement, or alterations, modifications, changes, additions and the like thereto, including without limitation all documents indicating the size, shape, configuration and/or materials, to be incorporated; all site plans, excavation and grading plans, elevation drawings, floor plans, techniques, samples of exterior colors, plans for utility services, and all other documentation or information relevant to the improvement or proposal in question.
- x. "Plat Map" shall mean and refer to the "Record of Survey Map or Maps of, as it may be amended from time to time. The Plat Map will show the location of the Lots.

- y. "Project" shall mean the Subdivision.
 - z. "Recreational, Oversized or Commercial Vehicle" shall mean and refer to any recreational, commercial or oversized vehicle, motor home, commercial vehicle, tractor, golf cart, mobile home or trailer (either with or without wheels), camper, camper trailer, boat or other water craft, boat trailer, horse trailer, or any other recreational, oversized or commercial transportation device of any kind.
 - aa. "Subdivision" shall mean PHEASANT POINTE NORTH.
2. **Area of Application.** This Declaration shall apply to all of the Property.
3. **Right to Expand Application.** Without any other additional approval required, the Declarant shall have the exclusive, unconditional, and irrevocable right to expand the application of this Declaration to other real property by written amendment to this Declaration duly recorded.
4. **Membership and Voting Rights.** Every owner shall be a Member of the Association. Membership in the Association shall be mandatory, shall be appurtenant to the Lot in which the Owner has the necessary interest, and shall not be separate from the Lot to which it appertains.
5. **Voting Rights.** The Association shall have the following described two classes of voting membership:
- Class A:** Class A Members shall be all Owners other than the Declarant until Class B membership ceases. Class A Members shall be entitled to one vote for each Lot in which the interest required for membership in the Association is held. In no event, however, shall more than one Class A vote exist with respect to any one Lot.
 - Class B:** The Class B Member shall be the Declarant or its assignee. The Class B Member shall be entitled to three (3) votes for each Lot in which it holds the interest required for Membership in the Association. The Class B Membership shall automatically cease and be converted to a Class A membership on the first to occur of the following events:
 - a. When the total number of votes held by all Class A Members equals the total number of votes held by the Class B Member; or
 - b. The expiration of seven (7) years after the date on which this Declaration is filed for record in the office of the County Recorder of

Utah County, Utah.

6. **Assessments.** Each Owner shall, by acquiring a Lot, be deemed to covenant and agree to pay to the Association the assessments described in this Section for the maintenance and cost associated with the ownership of the Common Area and maintenance of the Park Strip Improvements. All such amounts shall be, constitute, and remain a charge and continuing lien upon the Lot with respect to which such assessment is made; and shall be the personal obligation of the Owner at the time the assessment falls due. No Owner may exempt himself or his Lot from the liability for payment of assessments by waiver of his rights to use the Common Area or by abandonment of his Lot.

In a voluntary conveyance of a Lot, the grantee shall be jointly and severally liable with the grantor for all such unpaid assessments, late payment fees, interest and costs of collection, including reasonable attorneys fees, which shall be a charge on the Lot at the time of the conveyance, without prejudice to the grantee's right to recover from the grantor the amounts paid by the grantee therefore.

7. **Purpose of Assessments.** The Association is responsible for the maintenance and cost associated with the ownership of the Common Area and maintenance of the public owned Park Strip Improvements, including the payment of the payment to Lehi City the pressurized irrigation bill for the common areas. Assessments levied by the Association shall be used exclusively for the purpose of promoting the health, safety, and welfare of residents of the Project, including but not limited to, payment of the cost of taxes and insurance on the Common Area; the maintenance, repair and improvement of the Common Area and the public owned Park Strip Improvements; and the establishment and funding of a reserve to cover major repair or replacement of improvements within the Common Areas or Park Strip Improvements.

8. **Architectural and Related Issues.** Since aesthetics, the integrity and harmony of the original design, and the quality of construction and materials throughout the Subdivision is important, all architectural designs, plans, specifications, construction materials, and construction must be (a) reviewed and approved by the ARC or its designee and (b) consistent with the restrictions set forth herein governing the Subdivision.

9. **Architectural Review Committee ("ARC").** Until the termination of the "Period of Declarants Control," the ARC has the sole right and exclusive authority to resolve all architectural issues and may, in its sole discretion, designate one or more persons from time to time to act on its behalf in reviewing applications hereunder as the ARC, which before the termination of the "Period of Declarants Control" shall consist of three individuals, two of whom must be appointed by Declarants and the third must be

appointed by the Declarants, and thereafter may consist of (a) a single individual, architect or engineer, or (b) a committee comprised of architects, engineers or other persons who may or may not be Owners, or (c) a combination thereof. Powers may be delegated by the ARC, provided any such delegation shall specify the scope of responsibilities delegated, and, prior to the termination of the Period of Declarant's Control, shall be subject to the irrevocable right of Declarant to revoke such delegation at any time and reassume jurisdiction over the matters previously delegated and/or to veto any decision which Declarants determines, in its sole discretion, to be inappropriate or inadvisable. The initial ARC will be made up of Warren Kiggins, Sean Glather, and Richard Welch who shall serve until such time as their successors are qualified and appointed. a. Terms. Members serving on the ARC shall be appointed or elected to serve two (2) year terms. Any member of the ARC who fails on three (3) successive occasions to attend regularly scheduled meetings or who has failed to attend at least twenty-five percent (25%) of all regularly scheduled meetings held during any twelve (12) month period shall automatically forfeit his seat. Except for members of the ARC appointed by the Declarant prior to the termination of the Period of Declarant's Control, members of the ARC may be removed at any time by the affirmative vote of at least a majority of the Owners. Unless he forfeits or otherwise loses his seat as herein provided, a member shall serve on the ARC until his successor qualifies and is properly appointed by the Declarant or, after the termination of the Period of Declarant's Control, elected by the Owners. Members of ARC shall not be compensated for their services, although they may be reimbursed for costs advanced.

10. **Transfer of Control of ARC.** Within forty-five (45) days after the termination of the Period of Declarants Control (unless otherwise agreed), Declarants shall transfer the right to appoint two members of the ARC to the Lot Owners acting as a group in accordance with this Declaration.

11. **Procedures for Approval of Plans and Specifications.** Architectural designs, plans and specifications showing the nature, kind, shape, color, size, materials, and location of all proposed structures and improvements shall be submitted to the ARC for review and approval (or disapproval). In addition, information concerning irrigation systems, drainage, lighting, landscaping and other features of proposed construction shall be submitted as applicable. In reviewing each submission, the ARC may consider the proposed design, harmony of external design with existing structures and the common scheme, the location in relation to surrounding structures, topography, finish grade and elevation, among other things. Decisions of the ARC may be based on purely aesthetic considerations. Each Owner acknowledges that opinions on aesthetic matters are subjective and may vary as ARC members change over time. In the event that the ARC fails to approve or to disapprove any application within thirty (30) days after submission of all information and materials reasonably requested, the application shall be deemed approved; provided, however, anything to the contrary notwithstanding, no Dwelling shall

be constructed or altered unless it meets the following minimum requirements:

- a. Only single-family residential dwellings are allowed.
- b. The height of any Dwelling shall not exceed two stories above ground.
- c. Each Dwelling must have a minimum square footage as outlined in "Exhibit "C" Design Guidelines."
- d. Without the prior written consent of the ARC, a basement is required for each Dwelling.
- e. Without the prior written consent of the ARC, each Dwelling shall have a private garage for not less than two motor vehicles.
- f. At least 70% of the exterior surfaces of the Dwellings (excluding the roofs) must consist of stucco, brick or stone. Up to thirty percent (30.0%) of the surfaces may be vinyl siding if it is a high quality siding. Aluminum soffit and/or fascia is allowable but aluminum siding is not.
- g. Any detached accessory building must conform in design and materials
- c. with the primary residential Dwelling.
- h. All front yards of Lots shall be fully landscaped by the builder within 90 days of the closing on the transaction unless occupancy first occurs during the winter months in which case the required landscaping shall be installed within 90 days from the start of the next growing season. Landscaping and all grading and drainage shall be designed in such a way to control water run-off so that any Lot within the Subdivision will not be adversely affected by another. Furthermore, the grades initially established by the ARC or Declarants may not be altered without the prior written consent of the ARC. All landscaping must conform to the Landscaping Guidelines adopted by the ARC.
- i. No fence or similar structure shall be built in any front yard to a height in excess of four (4') feet, nor shall any fence or similar structure be built in any side or rear yard in excess of six (6) feet. Chain link fencing is not be allowed. Tan vinyl, ornamental wrought iron, or masonry fencing is permitted. Any fencing or similar structure using other construction materials requires the prior written approval of the ARC. If there is a dispute as to what constitutes the front, side or rear yards, the decision of the ARC shall be final, binding and conclusive. Owners of Lots 1 and 26 – 44 shall not erect an additional fence adjacent to the wrought iron fence installed by the Declarant along the 3200 North and 1200 West frontage.
- j. Designs submitted for approval shall be limited to those prepared by architects or

by qualified residential designers of outstanding ability whose previous work may be reviewed as a part of the approval process.

12. Preliminary Architectural Drawings, Plans and Specifications. The ARC may require, as a minimum, the following:

- k. Plot plan to scale of entire site with buildings located and elevation of floors shown above or below a designated point on the street.
- l. Floor plans of each floor level to scale.
- m. Elevations to scale of all sides of the Dwelling.
- n. One major section through Dwelling.
- o. A perspective (optional).
- p. Specifications of all outside materials to be used on the exterior of the Dwelling.

13. Final Plans and Specifications and Working Drawings. The ARC may require, as a minimum, the following:

- q. Plot plans to scale showing the entire site, building, garages, walks, drives, fence, carriage lights, retaining walls, with elevations of the existing and finished grade and contours including those at the outside corners of the buildings and at adjacent property lines and street fronts, and elevations of floors from a designated point on the street.
- r. Detailed floor plans.
- s. Detailed elevations, indicating all materials and showing existing and finished grades.
- t. Detailed sections, cross and longitudinal.
- u. Details of cornices, porches, windows, doors, garages, garden walls, steps, patios, fences, carriage lights, etc. Specifications shall give complete description of materials to be used with supplements, addendums or riders noting the colors of all materials to be used on the exterior of the Dwelling.

14. No Waiver of Future Approvals. The approval of the ARC of any proposals or plans and specifications or drawings for any work done or proposed, or in connection with any other matter requiring the approval and consent of such Committee, shall not be

deemed to constitute a waiver of any right to withhold approval or consent as to any similar proposals, plans and specifications, drawings or matters whatever subsequently or additionally submitted for approval or consent.

15. **Variance.** The ARC may authorize variances from compliance with any of the architectural guidelines when circumstances such as topography, natural obstructions, hardship, aesthetic, or environmental considerations require, but only in accordance with its duly adopted rules and regulations. Such variances may only be granted, however, when unique circumstances dictate and no variance shall (a) be effective unless in writing, (b) be contrary to the restrictions set forth in the body of this Declaration, or (c) estop the ARC from denying a variance in other circumstances. For purposes of this Section, the inability to obtain approval of any governmental agency, the issuance of any permit or the terms of financing shall not be considered a hardship warranting a variance. Any variance granted by the ARC with regard to setbacks or other Lehi City zoning issues addressed in the approval of the Pheasant Pointe North PUD would also require consideration and approval by the Lehi City Board of Adjustments.

16. **Limitation of Liability.** Neither the Declarants nor the ARC, or any of their employees, agents, representatives or consultants shall be responsible in any way for any defects in any plans or specifications submitted, revised or approved in accordance with the provisions of this Declaration, nor for any structural or other defects in any work done according to such plans and specifications. By accepting a deed or other document of conveyance to a Lot, each Owner agrees to and shall defend, indemnify, save and hold the Declarants and the ARC, and their employees, agents, representatives or consultants, harmless from any and all loss, damage or liability they may suffer, including defense costs and attorney fees, as a result of any claims, demands, actions, costs, expenses, awards or judgments arising out of their review or approval of architectural designs, plans and specifications.

17. **Enforcement of Architectural Guidelines.** Any construction, alteration, or other work done in violation of this Declaration shall be considered to be nonconforming. Upon written request from the ARC an Owner shall at his own cost and expense remove such non-conforming construction, alteration, or other work and shall restore the land to substantially the same condition as existed prior to the non-conforming construction, alteration, or other work. Should an Owner fail to remove and restore as required hereunder, the ARC shall have the right to enter the property, remove the violation, and restore the property to substantially the same condition as existed prior to the construction, alteration or other work, without being deemed to be a trespasser. Lehi City shall have the same rights as the ARC to enforce these guidelines at their discretion.

18. **Contractors.** Any contractor, subcontractor, agent, employee, or other invitee of an Owner who fails to comply with the terms and provisions of this Declaration may be

excluded by the ARC from the Subdivision, subject to the notice and the opportunity to be heard. In the event of sanctions after notice and hearing, neither the ARC or the Declarants, nor their employees, agents, representatives or consultants shall be held liable to any person for exercising the rights granted by this Section.

19. **Association Powers and Standing of Association.** Any instrument executed by the Association or its legal representative that recites facts which, if true, would establish the power and authority to accomplish through such instrument what is purported to be accomplished thereby, shall conclusively establish said power and authority in favor of any person who in good faith and for value relies upon said instrument. The Association shall constitute a legal entity capable of dealing in its own name or in behalf of two or more Owners. The Association shall have the authority and standing to pursue all legal and equitable remedies available to enforce the provisions of this Section and its decisions, including without limitation:

a. **Access.** The power and authority to enter into or upon any Lot to make inspections, evaluations or repairs and to do other work necessary for the proper maintenance and operation of the Subdivision or to enforce the decisions of the Association. Except in the case of an emergency, residents shall be given at least twenty-four (24) hours prior notice before the Association may exercise this power.

b. **Execute Documents.** The authority to execute and record, on behalf of the Association, any amendment to the Declaration which has been approved by the vote or consent necessary to authorize such amendment.

c. **Standing.** The power to sue and be sued.

d. **Contractual Authority.** The authority to enter into contracts which in any way concern the Subdivision.

e. **Promulgate Rules.** The authority to promulgate such reasonable rules and regulations as may be necessary or desirable to aid the Association in carrying out any of its functions.

f. **Determine Common Expenses.** The authority to determine the Common Expenses of operating the Association and administering the Declaration.

g. **Assessments.** The authority to assess each Lot Owner his share of the Common Expenses.

h. **All other Acts.** The power and authority to perform any and all other acts, and to enter into any other transactions which may be reasonably necessary for the Association to

perform its functions for and in behalf of the Owners.

20. **Use Restrictions and Nature of the Project.** The Lots are subject to the following use restrictions which shall govern both the architecture and the activities within the Subdivision:

a. **Private Residence.** No Lot shall be used except for residential purposes and all residents shall be obligated by the following requirements: no temporary structure including trailers, tents, shacks, garages, barns or other outbuildings shall be used on any Lot at any time. No Dwelling shall be rented on a seasonal basis or for hotel or transient use. Individual rooms may not be rented to separate persons. The initial term of any lease shall be at least six (6) months. All leases shall be in writing; a copy shall be provided to the Association.

b. **Business Use.** No commercial trade or business may be conducted in or from any Dwelling unless: (1) the existence or operation of the business activity is not apparent or detectable by sight, sound, or smell from outside the Dwelling; (2) the business activity conforms to all zoning requirements for the Subdivision; (3) the business activity does not involve persons coming onto the Subdivision who do not reside in the Subdivision or door-to-door solicitation of residents of the Subdivision; and (4) the business activity is consistent with the residential character of the Subdivision and does not constitute a nuisance, or a hazardous or offensive use, or threaten the security or safety of other residents of the Subdivision, as may be determined in the sole discretion of the Association. Notwithstanding the foregoing, the leasing of a Dwelling shall not be considered a trade or business within the meaning of this subsection.

c. **Storage and Parking of Vehicles.** The driving, parking, standing, and storing of motor vehicles in, on or about the Subdivision shall be subject to the following:

- 1) The parking rules and regulations adopted by the Association from time to time;
- 2) No motor vehicle or trailer, including but not limited to any car, automobile, truck, van, or any other transportation device of any kind may be parked or stationed in such a manner so as to block access to any driveway or Dwelling or to create an obstacle or potentially dangerous condition.
- 3) No Resident shall repair or restore any vehicle of any kind in, on or about any Lot, except for emergency repairs, and then only to the extent necessary to enable movement thereof to a proper repair facility.
- 4) No garage may be altered in such a manner that the number of motor vehicles which may reasonably be parked therein after the alteration is less than the number of

motor vehicles that could have been reasonably parked in the garage as originally designed and constructed.

- 5) All garages shall be used primarily for the parking and storage of vehicles.
- 6) Daytime parking on the street is allowed.
- 7) Overnight parking on the street is not allowed.
- 8) All motor vehicles parked so as to be visible from the street or another Lot must be undamaged (less than \$1,000.00 to repair), in good mechanical condition, registered, and licensed.
- 9) Except as otherwise expressly permitted, motor vehicles may not be stored so as to be visible from the street or another Dwelling.
- 10) Recreational, Commercial, and Oversized Vehicles may be stored on a Parking Pad behind a Parking Pad Fence provided (a) it is located in a side yard behind the houseline or in the rear of the Lot, and (b) it is in running condition and properly licensed.
- 11) Vehicles parked in violation of this Declaration may be immobilized, impounded, or towed by the Association or its designee without further notice and at the owner's sole risk and expense.

d. **Maintenance.** All Lots and Dwellings shall be kept by the Owner in good repair and maintenance and in a clean, safe, sanitary and attractive condition.

e. **Garbage and Refuse Disposal.** No Lot shall be used as a dumping ground. All trash, garbage, debris, rubbish or other waste shall be kept in a sealed, sanitary bag or container, and stored out of sight except for a twenty-four (24) hour period on pick-up days.

f. **Aerials, Antennas, and Satellite Systems.** No aerials, antennas, satellite dishes or systems shall be erected, maintained or used in, on or about any Dwelling, outdoors and above ground, whether attached to or on top of any building, structure, Dwelling, or otherwise, within the Subdivision without the prior written consent of the Declarant or Association, which shall not be unreasonably withheld. In making its decisions, the Declarants and/or ASSOCIATION shall abide by and be subject to all relevant local, state and federal laws, including but not limited to all FCC guidelines, rules and regulations as they may be amended or supplemented from time to time. Insofar as is reasonably possible without impairing reception, satellite dishes, aerials and antennae shall be positioned so that they are screened from view from the street.

g. **Animals and Pets.** The keeping of animals other than those ordinarily kept as family pets within the Subdivision is forbidden. No pets, animals, livestock or poultry of any kind shall be bred in, on or about the Project. Up to two domestic pets per Dwelling are allowed; provided, however, all pets must be properly licensed and registered (if required) with the appropriate governmental agencies and follow all applicable local ordinances. Pets may not create a nuisance. The following acts of an animal may constitute a nuisance: (1) it causes damage to the property of anyone other than its owner; (2) it causes unreasonable fouling of the air by odors; (3) it causes unsanitary conditions; (4) it defecates on any common area and the feces are not immediately cleaned up by the responsible party; (5) it barks, whines or howls, or makes other disturbing noises in an excessive, continuous or untimely fashion; (6) it molests or harasses passersby by lunging at them or chasing passing vehicles; (7) it attacks people or other domestic animals; (8) it otherwise acts so as to bother, annoy or disturb other reasonable residents or interferes with their right to the peaceful and quiet enjoyment of their property; or (9) by virtue of the number of pets maintained, they are offensive or dangerous to the health, welfare or safety of other residents. Pets in the Subdivision at large must be behind a fence, in a cage or on a leash and under the control of a responsible person.

h. **Laws.** Nothing shall be done or kept in, on or about any Lot or any part thereof, which would be a violation of any statute, rule, ordinance, regulation, permit or other validly imposed requirement of any governmental body.

i. **Damage or Waste.** Each Owner shall repair any damage he or any other residents, guests, or invitees of his Lot may cause to another Owner, Lot, or Dwelling, and promptly restore the property to its original condition.

j. **Signs.** No signs, billboards or advertising structures may be built or displayed on the Property or any Lot except for a single sign with a maximum size of 2' x 2' for specific purpose of advertising the sale or rental of a Dwelling; provided, however, this requirement does not relate to Declarant, who may use whatever signs it deems appropriate to market its Lots.

k. **Zoning.** All land use and buildings shall be in compliance with all zoning and land use ordinances as well as all regulations of the municipalities and agencies governing the Subdivision land use and buildings.

l. **Landscaping.** All landscaping, grading, and drainage of the land in each Lot shall be completed strictly in accordance with the Declarant's Landscaping Guidelines, and so as to comply with and not impair all Utah County Ordinances and flood control requirements.

m. **Easements.** Easements and rights of way for the installation and maintenance of utilities, drainage systems and facilities, and irrigation are reserved, as set forth herein and in the legal descriptions of the Property. Within these easements and rights of way, no structure, planting or other materials shall be placed or permitted to remain which may damage or interfere with the installation and maintenance of utilities, or which may change the direction of flow of drainage channels in, on or about the easements and rights of way, or which may obstruct or retard the flow of water through the drainage channels in the easements and rights of way. The easement and right of way area of each Lot and all improvements within said area shall be maintained continuously by their Owners, excepting those improvements for which a public authority or utility company is expressly responsible.

n. **Slope and Drainage Control.** No structure, plant, improvement or other material may be placed or permitted to remain, or other activities undertaken which may damage or interfere with established Lot ratios, create erosion or sliding problems, or which may change the direction or flow of drainage channels, or obstruct or retard the flow of water through the channels. The slope control area of each Lot and all improvements therein shall be maintained continuously by the Owner of the Lot, excepting those improvements for which a public authority or utility company is expressly responsible. It shall be the responsibility of the Owner to see that his Lot strictly conforms with the grading and drainage plan established by the Declarants and Utah County.

o. **Nuisances.** No noxious or offensive activity shall be carried on, in or about the Property, nor shall anything be done or permitted thereon which may be or may become an annoyance, disturbance, bother or nuisance to the neighborhood, or which might interfere with the right of other residents to the quiet and peaceful enjoyment of their property.

p. **Temporary Structures.** No structure of a temporary nature or character, including but not limited to any trailer, shack, shed, tent, garage, barn or other out-building shall be used on any Lot at any time as a residence.

21. **Declarant's Sales Program.** Notwithstanding anything to the contrary, until the termination of the Period of Declarant's Control neither the Owners nor the Declarant shall interfere or attempt to interfere with Declarant's completion of improvements and sale of all of its remaining Lots and Dwellings, and Declarant shall have the following rights in furtherance of any sales, promotions or other activities designed to accomplish or facilitate the sale of all Lots and Dwellings owned by it:

a. **Sales Office and Models.** Declarants shall have the right to maintain one (1) or more sales offices and one (1) or more model Lots, Homes or Dwelling at any one time. Such office and/or models may be one or more of the Lots owned by it, or one or more of any

separate structures or facilities placed on the Property for the purpose of aiding Declarant's sales effort, or any combination of the foregoing; furthermore, the Declarant shall comply with all City codes and ordinances that pertain to this section; specifically section 09.070. Model Homes. Chapter 9 of the Lehi City Development Code which requires that the Declarant obtain approval from the Lehi City Planning Commission of the sales office and model home(s) as a conditional use.

b. **Promotional.** Declarant shall have the right to maintain a reasonable number of promotional, advertising and/or directional signs, banners or similar devices at any place or places on the Property.

c. **Relocation and Removal.** Declarant shall have the right from time to time to locate or relocate any of its sales offices, models, or signs, banners or similar devices, but in connection with each such location or relocation shall observe the limitations imposed by the preceding portion of this Section. Within a reasonable period of time after the happening of the occurrence, Declarant shall have the right to remove from the Subdivision any signs, banners or similar devices and any separate structure or facility which was placed on the Property for the purpose of aiding Declarant's sales effort.

d. **Limitation on Improvements by the ASSOCIATION.** Until the termination of the Period of Declarant Control, neither the Owners nor the Declarant shall, without the written consent of Declarant, make any improvement to the Subdivision or alteration to any improvement created or constructed by Declarant.

e. **Declarant's Rights Assignable.** All of the rights of Declarant under this Declaration may be assigned or transferred either by operation of law or through a voluntary conveyance, transfer or assignment. Any Mortgage covering all Lots or Dwellings in the Subdivision title to which is vested in Declarant shall, at any given point in time and whether or not such Mortgage does so by its terms, automatically cover, encumber, and include all of the then unexercised or then unused rights, powers, authority, privileges, protection and controls which are accorded to Declarant (in its capacity as Builder) herein.

22. **Interpretation.** To the extent Utah law is consistent with this Declaration, such provisions shall supplement the terms hereof and are incorporated herein. The captions which precede the Articles and Sections of this Declaration are for convenience only and shall in no way affect the manner in which any provision hereof is construed. Whenever the context so requires, the singular shall include the plural, the plural shall include the singular, the term "shall" is mandatory and the term "may" is permissive, the whole shall include any part thereof, and any gender shall include both other genders. The invalidity or unenforceability of any portion of this Declaration shall not affect the validity or enforceability of the remainder hereof.

23. **Covenants to Run with Land.** This Declaration and all the provisions hereof shall constitute covenants to run with the land or equitable servitudes, as the case may be, and shall be binding upon and shall inure to the benefit of the Declarant and all parties who hereafter acquire any interest in a Lot, the Subdivision or the Property, and their respective grantees, transferees, heirs, devisees, personal representative, successors, and assigns. Each Owner or resident of a Lot shall comply with, and all interests in all Lots shall be subject to, the terms of this Declaration and the provisions of any rules, regulations, agreements, instruments, supplements, amendments, and determinations contemplated by this Declaration. By acquiring any interest in a Lot, the party acquiring such interest consents to, and agrees to be bound by, each and every provision of this Declaration.

24. **Enforcement and Right to Recover Attorney's Fees.** Lehi City shall have the right, at their discretion, to enforce these CC&R's. Should the Declarant, ASSOCIATION, Lehi City or an aggrieved Owner be required to take action to enforce or construe the Declaration or any rules and regulations adopted from time to time, or to pursue any remedy provided hereunder or by applicable law, including a claim for injunctive relief or damages, whether such remedy is pursued by filing suit or otherwise, the prevailing party shall be entitled to recover his reasonable attorneys fees, costs and expenses which may arise or accrue.

25. **Limitation of Liability.** The protective covenants, conditions and restrictions set forth in this Declaration, together with any rules and regulations adopted by the Declarant or the ASSOCIATION, are established for the benefit of the Property and the Owners. Any damage, loss, claim or liability which might arise due to any decision, act, or failure to act of Declarant or the Committee or any of its members shall be exempt from any civil claim or action, including negligence, brought by any person owning or having an interest in any Lot. The Committee and its members shall be indemnified, saved and held harmless from any such action or failure to act, and exempt from any civil claim or action resulting from any act or failure to act (whether intended or implied) while functioning as a member of the ASSOCIATION, or for decisions that they may render during the course of their service, unless said party is guilty of gross negligence.

26. **Amendments.** This Declaration may be amended upon the affirmative written approval of at least a two-thirds (2/3) majority of the Owners of the Lots and upon written consent by Lehi City and shall then be valid immediately upon recording of the document amending the Declaration in the office of the County Recorder of Utah County, Utah; provided, however, (a) so long as Declarant ROCHELLE INVESTMENTS, L.C. shall own at least one (1) Lot in the Subdivision or until such time as the City waives this right in writing, no amendment shall be valid or enforceable without the express prior written consent of the Declarant ROCHELLE INVESTMENTS, L.C..

27. **Duration.** The covenants and restrictions of this Declaration shall endure for a term of twenty (20) years from the date this Declaration is recorded, after which time said covenants shall be automatically extended for successive periods of ten (10) years.

Dated the day and year first above written.

Declarant:

ROCHELLE INVESTMENTS, L.C.

By:  _____
Name: David C. Clark
Title: Manager

ACKNOWLEDGMENTS

STATE OF UTAH)
ss:
COUNTY UTAH)

y The foregoing instrument was acknowledged before me this 06 day of ~~September~~ ^{January} 2002 by David C. Clark, the Manager of ROCHELLE INVESTMENTS, L.C., a Utah limited liability company, and said David C. Clark duly acknowledged to me that said company executed the same.

Lara Amakom
NOTARY PUBLIC
Residing at:
My Commission Expires:

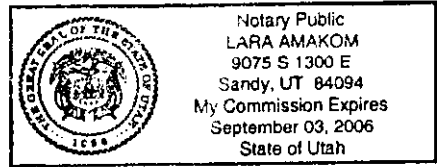

EXHIBIT "A"
LEGAL DESCRIPTION

The Property referred to in the foregoing document is located in Utah County, Utah and is described more particularly as follows:

Beginning at the East $\frac{1}{4}$ corner of Section 31, T4S, R1E, S.L.B. & M.; thence as follows: South $0^{\circ}09'44''$ West 437.23 feet along the section line; thence North $89^{\circ}48'30''$ West 762.96 feet; thence North $58^{\circ}46'55''$ West 346.47 feet; thence North 255.85 feet; thence South $89^{\circ}57'35''$ East 1,060.50 feet along the $\frac{1}{4}$ section line to the point of beginning. Contains: 10.00 acres.

EXHIBIT "B" LANDSCAPING GUIDELINES

The builder of the homes at Madison Place at Pheasant Pointe is required to install a basic front yard landscape package which includes the sideyards to the back corner of the house on each side and will include the following:

1. Automatic irrigation system for lawns and shrubs with an irrigation clock or timer.
2. Sod or hydroseeded lawn area in the front yard and planter strip.
3. At least 10 shrubs, 1 gallon size or larger, installed in planter beds adjacent to the front foundation of the home.
4. Two trees in the front yard. One is to be planted in the park strip between the sidewalk and the curb and is to be one of the following species: Honey locust maple; Autumn blaze maple; any variety of linden. The second tree is to be planted in the front yard. Corner lots are required to have a third tree which shall be planted in the park strip and shall be of the varieties mentioned above. All of the above referenced trees are to be 1.5" caliper or larger when planted.
5. Corner lots are required to include landscaping for the sideyard on the corner and the adjacent park strip.

Said landscaping must be installed within 90 days of home occupancy. If occupancy occurs during the winter months, then the required landscaping shall be installed within 90 days from the start of the next growing season.

EXHIBIT "C"

DESIGN GUIDELINES

Madison Place at Pheasant Pointe is one of four neighborhoods within the Pheasant Pointe Master Planned Community. Each neighborhood is unique with regards to the type of housing and price range it provides and yet, all four neighborhoods are integrated together by use of certain design elements and features. To this end, the following is a list of the design criteria and features to which all of the homes in Madison Place must comply.

1. Architectural Style

All homes are to reflect or be compatible with a "French Country" architectural theme.

2. Roof Pitch and Material

Minimum roof pitch is 5:12. Roof materials must be architectural style, dimensional shingles with a minimum warranty of 25 years.

3. Exterior Materials

At least 70% of the exterior building materials, excluding the roof, must be hard surface materials such as stucco, stone, cultured stone or brick. Aluminum soffit and/or fascia are allowed but no aluminum siding will be allowed. Any vinyl siding must be an attractive, high grade siding able to withstand high winds.

4. Architectural Design and Size

All homes must comply with the following:

- Include a 2-car garage or larger
- Have a minimum finished square footage on the main floor of 900 s.f. for ramblers. Two-story homes shall comply with one of the following two criteria:
 1. Have a minimum finished square footage of 900 s.f. on the main floor and a total finished square footage of at least 1300 s.f. excluding the basement. Or,
 2. Have a minimum finished square footage of 850 s.f. on the main floor and a total finished square footage of 1450 s.f. excluding the basement.
- Split level homes shall have a minimum square footage of 900 s.f. on the main floor, which floor is defined as the floor with the kitchen and living room.

5. Street Lights

The street lights must comply with the street light selected for all public streets within Pheasant Pointe.

6. Street Scene

No two adjacent homes shall have the same elevation or the same color scheme. No two homes directly across the street from each other shall have the same elevation or color scheme.

7. Garages

The location and treatment of the garage relative to the street shall be a critical design consideration. The following design considerations shall be implemented where feasible:

- a. It is desired that some of the homes have either side-load garages or garages that are recessed a minimum of 4 feet from the front elevation of the house.
- b. Garages that are flush with the front elevation of the home or that protrude forward of the front elevation shall incorporate the following design techniques:
 1. Windows in the garage door.
 2. Garage doors painted a color other than white so the door blends into the color scheme of the house and does not stand out.
 3. “Pop-outs” or framed elements extending outward a minimum of 12 inches beyond the garage door and wrapping around the garage door so as to create a shadow line on the garage door and to create a sense of the garage being recessed.

8. Setbacks

Minimum setbacks shall be as follows:

- a. Side yard setbacks: 5 feet
- b. Rear yard setbacks: 15 feet
- c. Front yard setbacks: 15 feet on interior lots. On corner lots, the front yard setback shall be such that the house does not encroach on the clear view area of the sight distance triangle as required by Lehi City. If no encroachment on the sight distance triangle occurs, the front yard setback shall be a minimum of 15 feet.

PHOENIX POINT NORTH LANDSCAPE PLANS

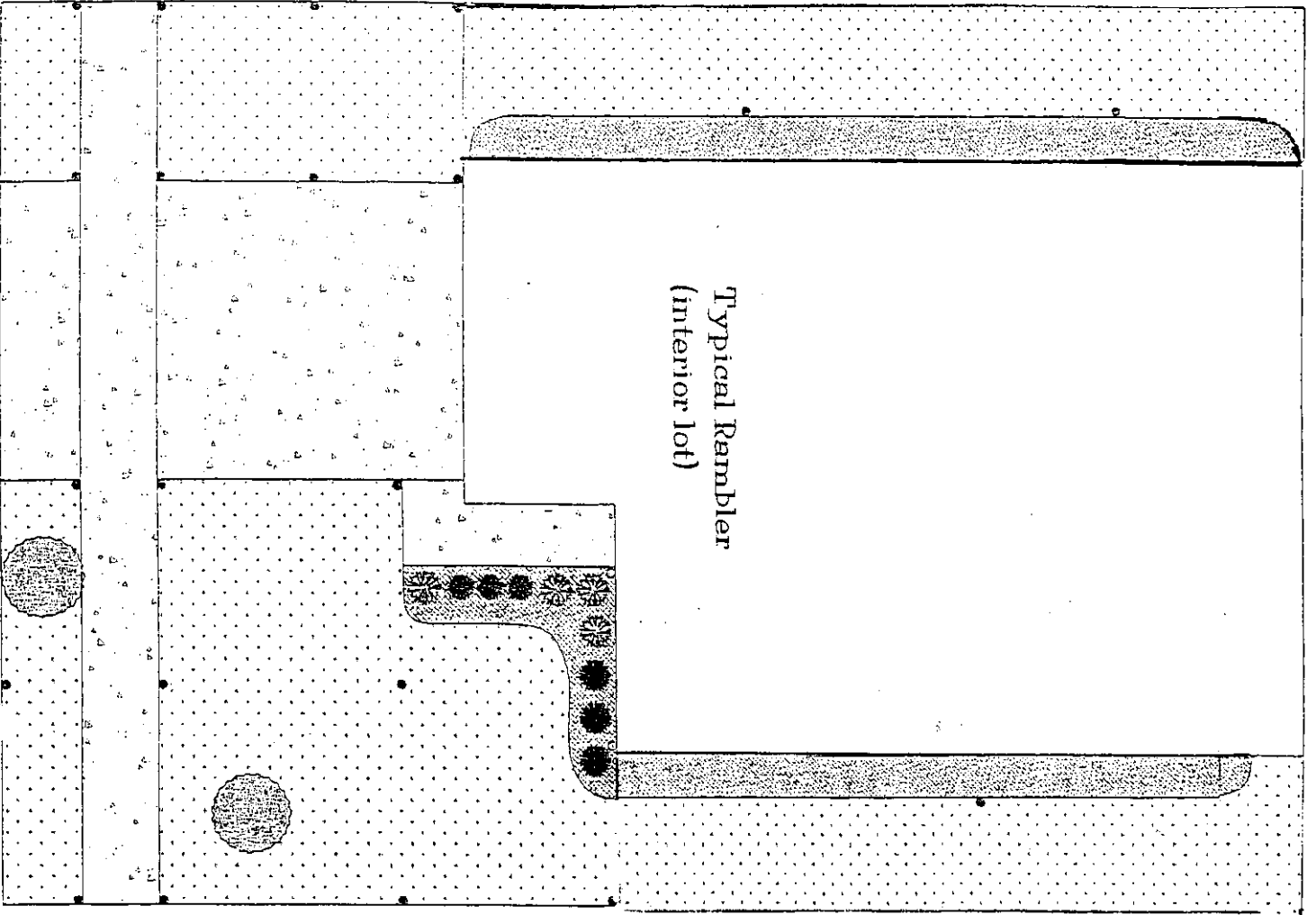

Exhibit "C"

Landscape Legend

- Hunter Pro-spray Pop-ups
- 18 inch risers
- Concrete
- Existing Structure
- ▨ Bark
- Grass
- Honey Locust (20 gal)
- Red Leaf Barberrry (1 gal)
- Japanese Yew (1 gal)
- Golden Privet (1 gal)

Pleasant Pointe North Landscape Plans

Typical Rambler
(CORNER LOT)

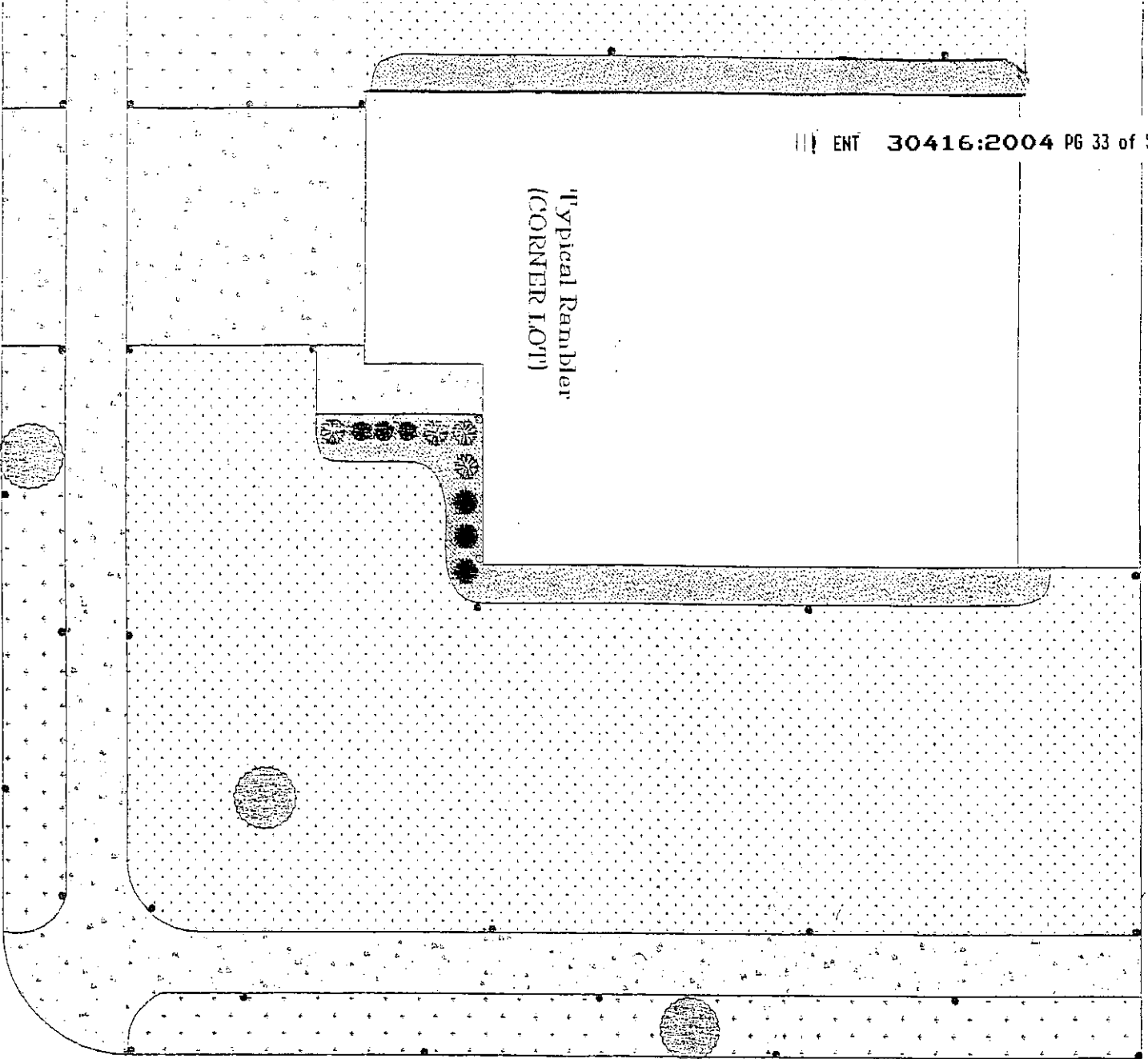

Landscape Legend

- Thunder Per-spray pop-ups
- 18 inch trees
- Concrete
- Existing Structure
- Bark
- Grass
- Honey Locust (20 gall)
- Red Leaf Barberry (1 gall)
- Japanese Yew (2 gall)
- Golden Privet (1 gall)

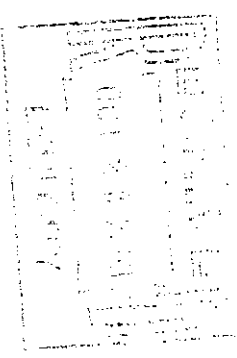

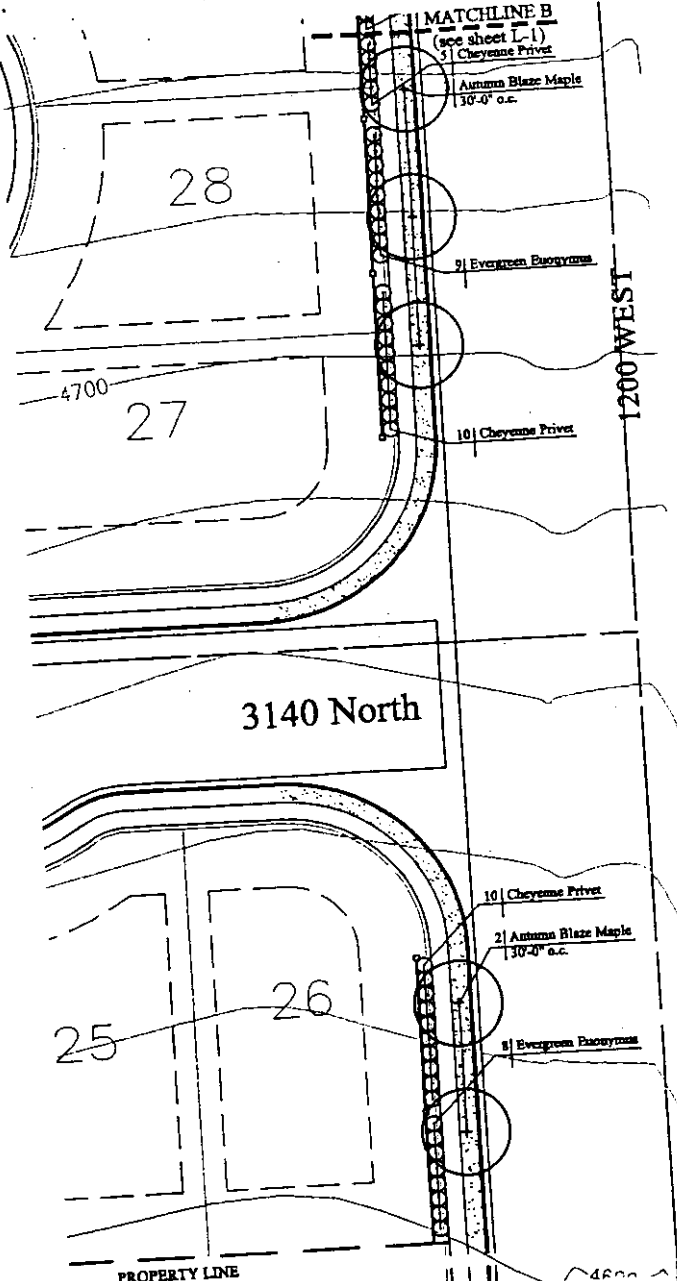

Plant Legend:

QUANTITY	SCIENTIFIC NAME	COMMON NAME
SHADE TREES		
34	ACER PLATANOIDES AUTUMN BLAZE	AUTUMN BLAZE MAPLE
11	TILIA CORDATA GREENSPICE	GREENSPICE LINDEN
ORNAMENTAL TREES		
5	MALUS SPURIA SNOW	SPRING SPUR CRAB
EVERGREEN TREES		
15	PIRUS PLECKII VANDERWOLF'S PYRAMID	VANDERWOLF'S PYR
MEDIUM AND SMALL SHRUBS		
116	COTYLEDON LUCIDUS	PICNIC GUTENBERG
114	CORNUS SERICEA BALLER	RED CURRANT DOGWOOD
36	LIGULIFLUM VULGARIS CHEYENNE	CHEYENNE PRIVET
34	BIGNONIA LAPONICA GREENSPICE	GREENSPICE LINDEN
LAWN		
3425.0	LAWN GRASS/SEED BERTANT BIRD	LAWN BIRD SEED
NO - VERIFY QUANTITIES OF SHRUBS AND ORNAMENTALS		

ENT 30416:2004 PG 34 of 50

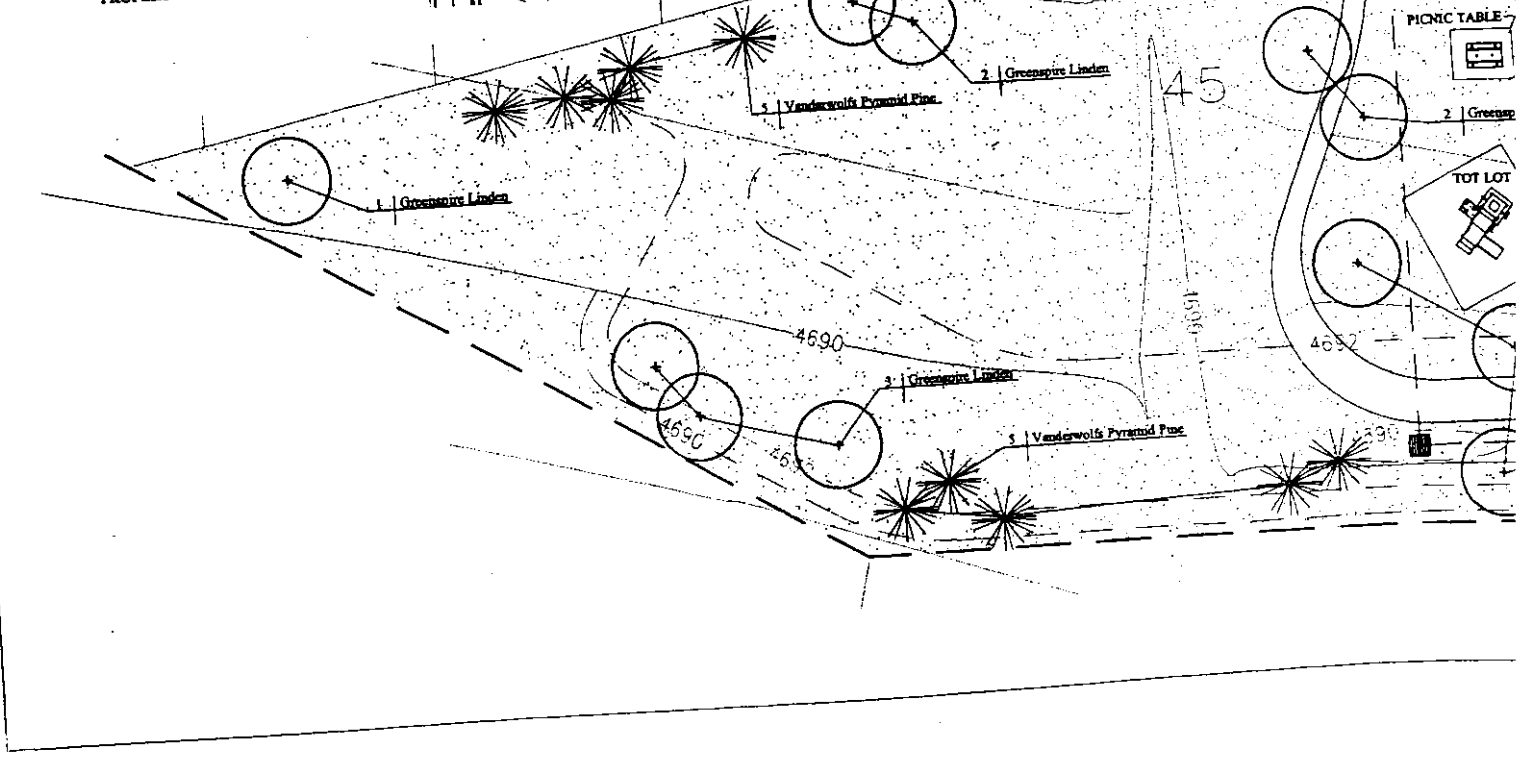

NAME	SIZE	SPACING
2 MAPLE	7" CAL.	10' O.C.
2 BUSH	7" CAL.	10' O.C.
CRABAPPLE	1 3/4" CAL.	As Shown
1 PYRAMID PINE	6" P.	As Shown
1 GREATER	1 GAL.	6" O.C.
1 COFFEE	1 GAL.	6" O.C.
1 SPY	1 GAL.	6" O.C.
1 ELDERBERRY	1 GAL.	6" O.C.
1 RED SPICE	SOD	N.A.

ENT 30416:2004 PG 35 of 50



Blake/McCutchan Design, Inc.
Landscape Architects & Land Planners
1790 South 1100 East
Salt Lake City, UT 84105
801.467.0067
Fax 801.484.6239
www.blakemccutchan.com
Formerly Swiner Design, Inc.

Pheasant Pointe North Landscape Plan

Rochelle Investments - L.C.
9075 South 1300 East
Sandy, UT 84094
(801)561-2525

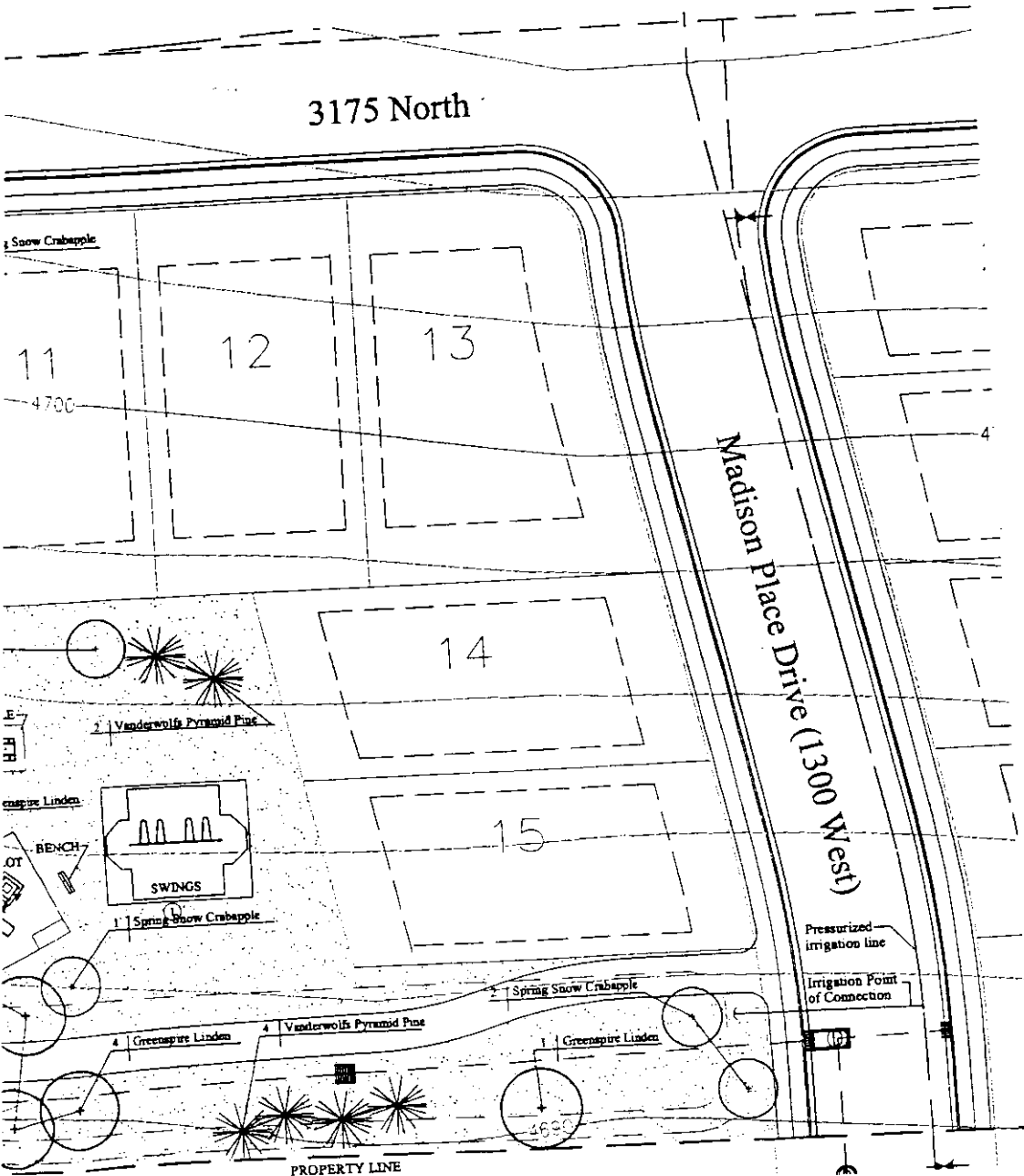

Project Location

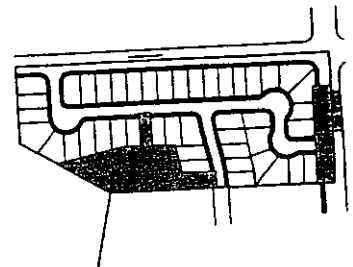

Project Information

Drawn By: JB Checked By: STB
Project Number:
Date: October 20, 2003

Scale/North

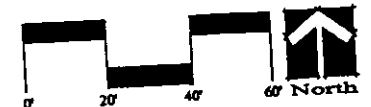

Sheet Title

Landscape Plan

Sheet Number

L-2

4710

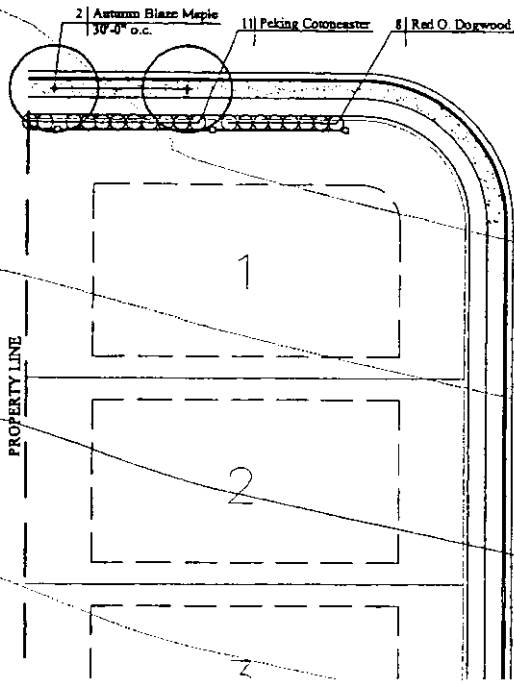

1420 West

4700

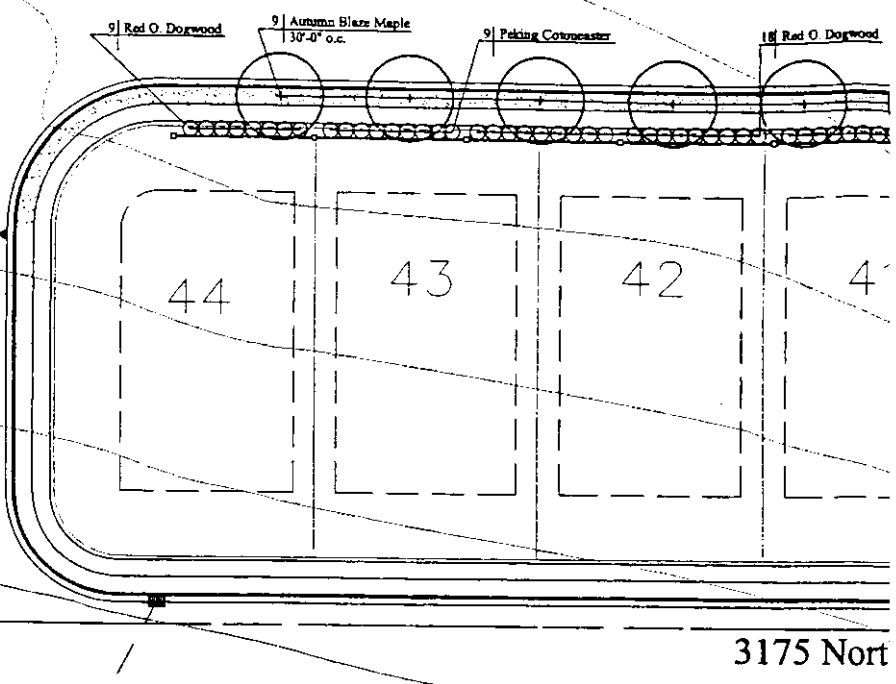

3175 North

3200 North

MATCHLINE

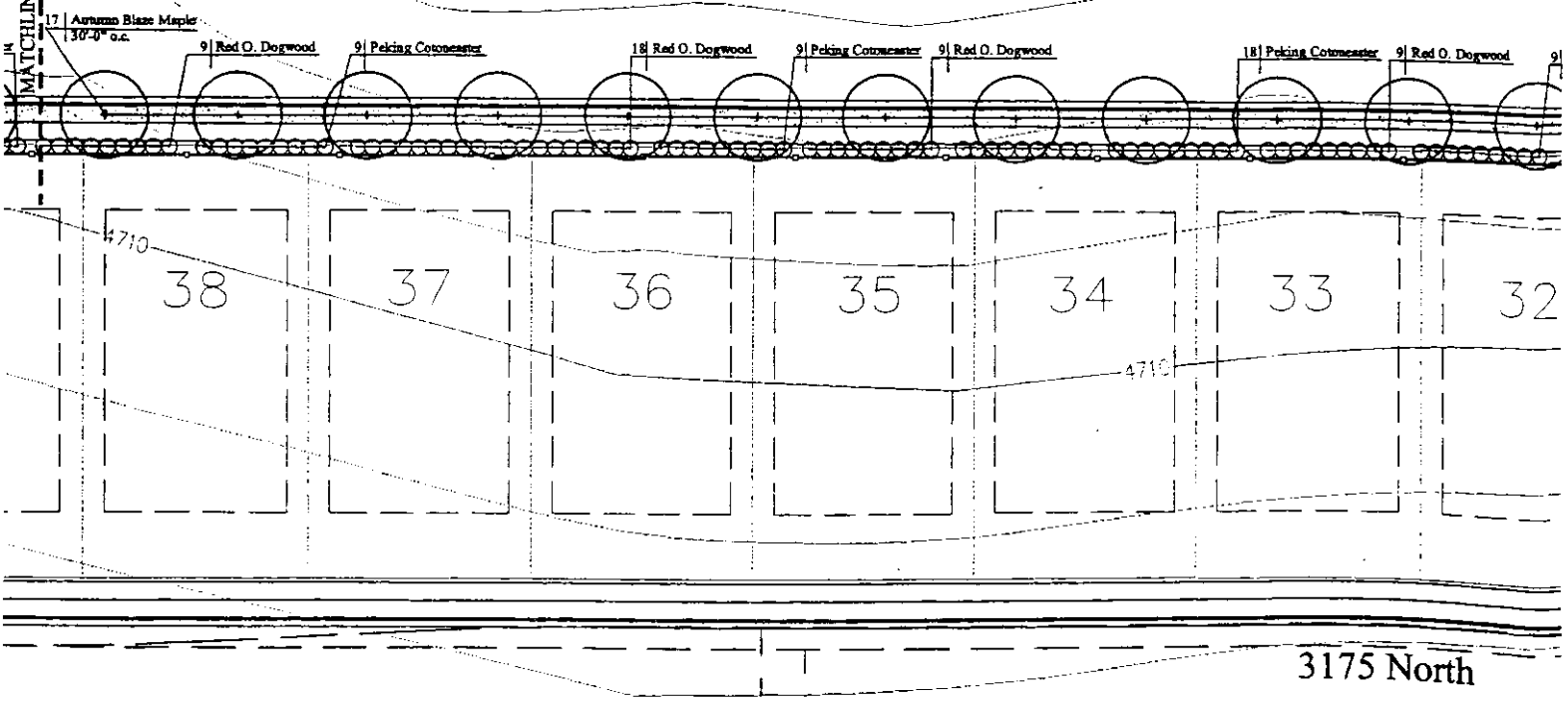

4710

3175 North



Blake McCutchan
Landscape Architects & Land Planners
Blake / McCutchan Design, Inc.
1790 South 1100 East
Salt Lake City, UT 84105
801.467.0067
Fax 801.484.6239
www.blakemccutchan.com

Plant Legend:

PLANTING LEGEND				
QUANTITY	SCIENTIFIC NAME	COMMON NAME	SIZE	SPACING
36	ACEA FLAMMULA AUTUMN BLAZE	AUTUMN BLAZE MAPLE	7" CAL.	36" O.C.
15	TRIAL CORDATA EVERGREEN	EVERGREEN LINDBERGH	7" CAL.	36" O.C.
1	MALUS SPINDA BIRD	SPINDA BIRD CRABAPPLE	1 1/2" CAL.	As Spec
15	FRAXINUS FLEXilis	WANDERWOLF PYRAMID FRAX	6" F	As Spec
15	CORYMBASTIS LACINIOSA	PEERING CORYMBASTIS	2 GAL.	4" O.C.
14	CORONILLA ALBA	RED OBER DOGFWOOD	2 GAL.	4" O.C.
30	LIGULIFRUM VILLOSUM	CHEYENNE PRIVET	2 GAL.	4" O.C.
30	ELAEAGNUS ARGENTEA	EVERGREEN EUONYMUS	2 GAL.	4" O.C.
LAWN				
1000 S.F.	LAWN GRASS (RESISTANT SOIL)	LAWN (100) (SEE SPEC)	100	K.A.

NOTE: VERIFY QUANTITIES OF SHRUBS AND GROUNDCOVERS

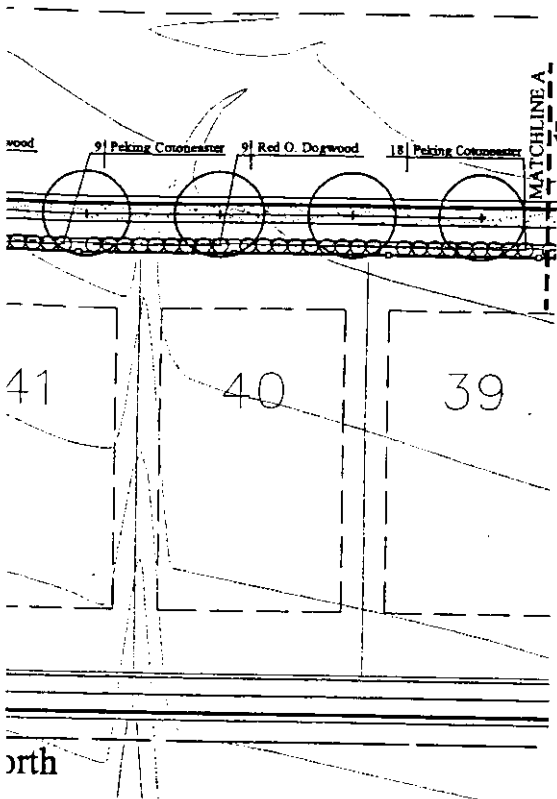

Pheasant Pointe North
Landscape Plan

Rochelle Investments - L.C.
9075 South 1300 East
Sandy, UT. 84094
(801) 561-2525

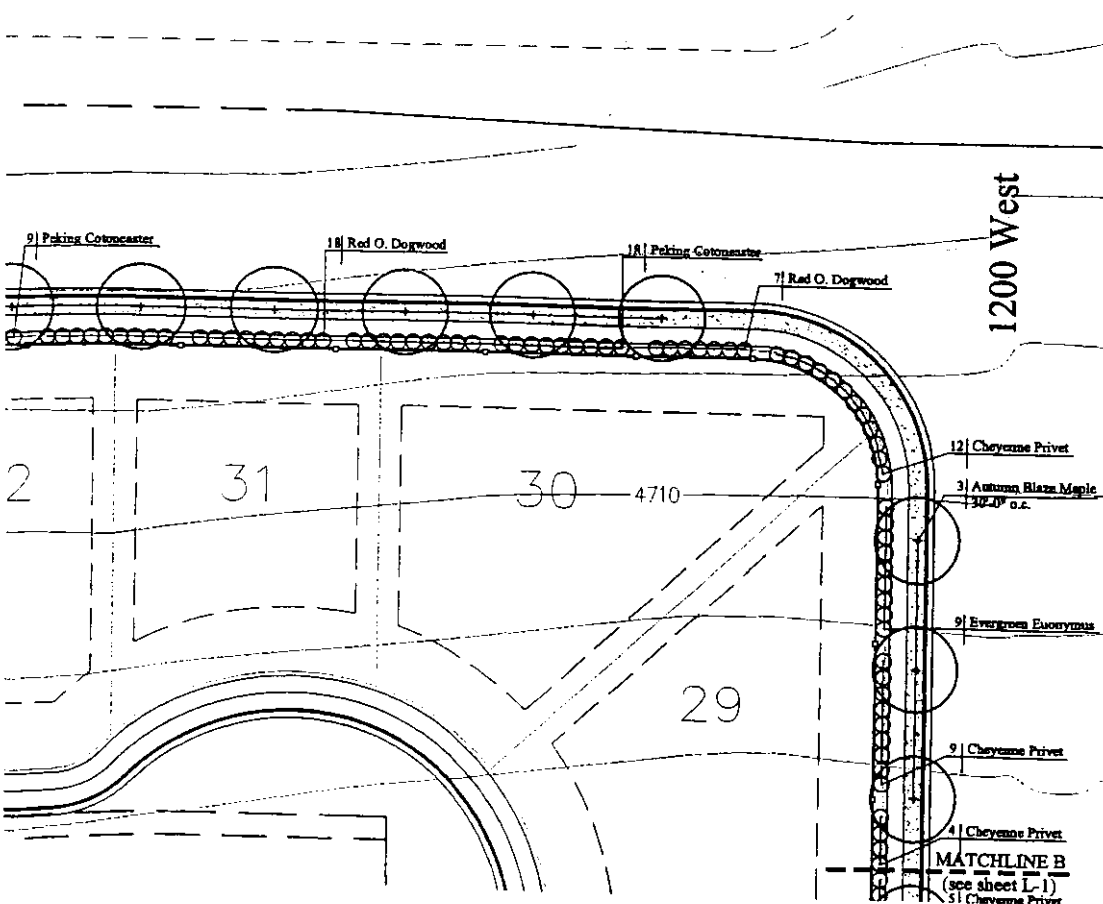

Project Location

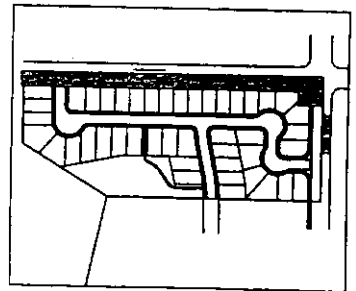

Project Information

Drawn By: JB Checked By: STB
Project Number:
Date: October 20, 2003

Scale/North



Sheet Title

Landscape Plan

Sheet Number

L-1

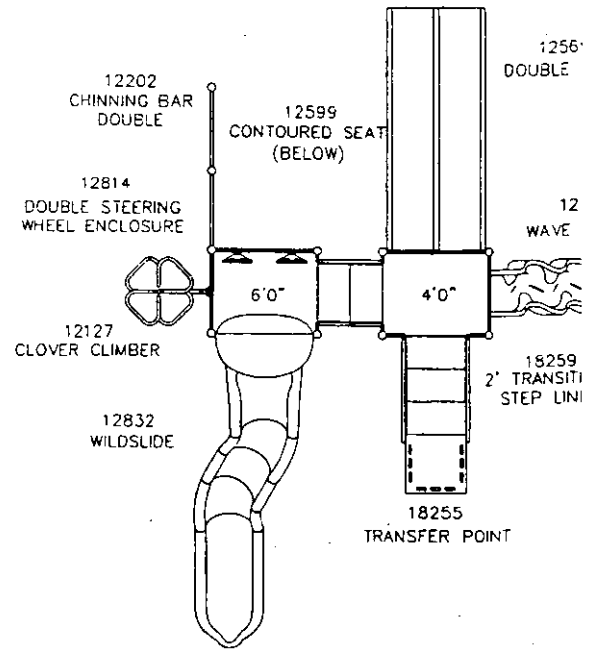
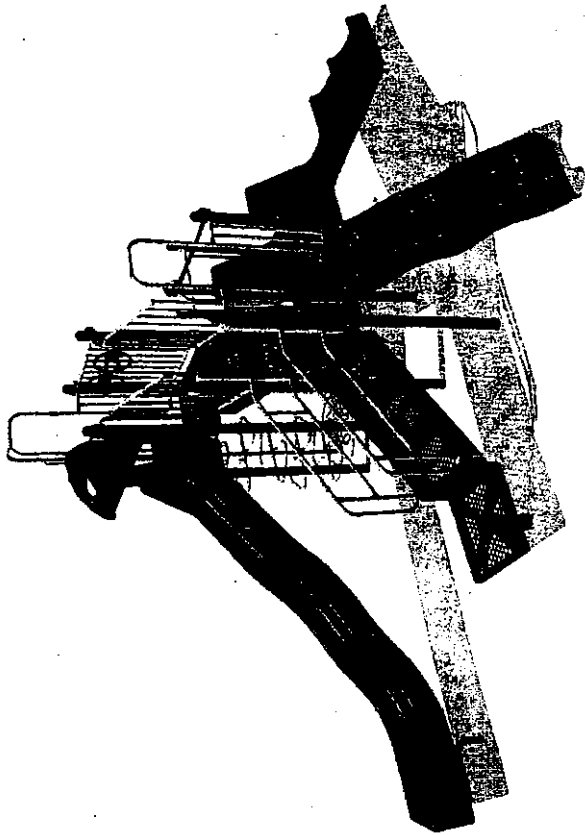

ENT 30416:2004 PG 38 of 50



Copyright 2007
By Gametime
Revision: 03/28/07

1835 PARK BENCH

NOTE: 1835 6' INGROUND GALVANIZED
P1835 6' INGROUND PAINTED
1837 6' PORTABLE GALVANIZED
P1837 6' PORTABLE PAINTED
1839 6' BOLT-DOWN GALVANIZED
P1839 6' BOLT-DOWN PAINTED
PLASTIC COATED BENCH

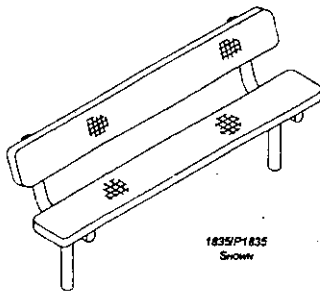

1835/P1835
SHOW

SPECIFICATIONS

FRAME: The frames shall be fabricated of 2-3/8" O.D. galvanized pipe.
SEAT AND BACK: The seat and back shall be expanded metal with a plastic coating.
HARDWARE: All nuts, bolts, screws, inserts, and lockwashers used in the assembly of all equipment shall be stainless steel, yellow dichromate plated steel, blue-coat plated steel, mechanically galvanized or powder coated/yellow dichromate plated steel. All primary fasteners shall be 305 series stainless steel. Fasteners with yellow dichromate treatment have an

electro deposited, 99.8% pure zinc substrate applied from a specially formulated solution sealed with a yellow dichromate top coat designed to work in conjunction with the zinc plating. Yellow dichromate has a 320% longer life to white corrosion and 275% longer to red corrosion than does hot-dip galvanizing.
NOTE: All weights are based on average comparisons of each part.
SPECIFICATIONS: Gametime has a policy of continuous improvement and reserves the right to discontinue or change specifications without notice.

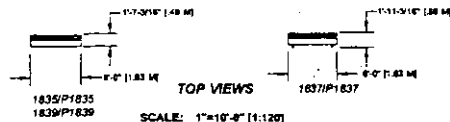

TOP VIEWS

SCALE: 1"=10'-0" (1:120)



Copyright 2007
By Gametime
Revision: 1/22/07

1866 PICNIC TABLE

NOTE: 1866 6' Table
1868 8'-2" Table
1870 Adjustable Table

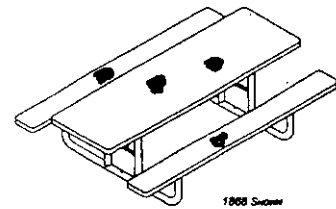

1866 SHOW

SPECIFICATIONS

FRAME: Shall be fabricated of 2-3/8" O.D. galvanized pipe.
DIAPHRAGM BRACE: Shall be fabricated of 1-1/2" O.D. galvanized pipe.
TABLE BRACE: Shall be fabricated from 1 1/2" hot rolled steel.
SEAT: Shall be fabricated from plastic coated expanded metal 2'-8" wide x 6'-0" long or 6'-2" long.
TOP: Shall be fabricated from plastic coated expanded metal 2'-8" x 6'-0" long or 6'-2" long.
FRAME: Frames shall have a powder coat finish.
HARDWARE: All nuts, bolts, screws, inserts, and lockwashers used in the assembly of all play equipment shall be stainless steel, yellow dichromate plated steel, blue-coat plated steel, mechanically galvanized or powder coated/yellow dichromate

plated steel. All primary fasteners shall be 30 series stainless steel. Fasteners with yellow dichromate treatment have an electro deposited, 99.8% pure zinc substrate applied from a specially formulated anodic seal with a yellow dichromate top coat designed to work in conjunction with the zinc plating. Yellow dichromate has a 320% longer life to white corrosion or 275% longer to red corrosion than does hot-dip galvanizing.
NOTE: All weights are based on average comparisons of each part.
SPECIFICATIONS: Gametime has a policy of continuous improvement and reserves the right to discontinue or change specifications without notice.

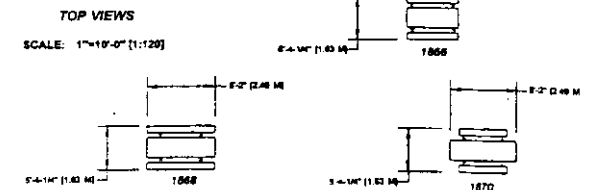

TOP VIEWS

SCALE: 1"=10'-0" (1:120)



8002 3-LEG TRADITIONAL SWINGS

Copyright 2002
By GameTime
Revised: 09/16/03

NOTE: HEAVY DUTY
8002, P8002
8004, P8004
8006, P8006
8003, P8003 Acc-A-Bay

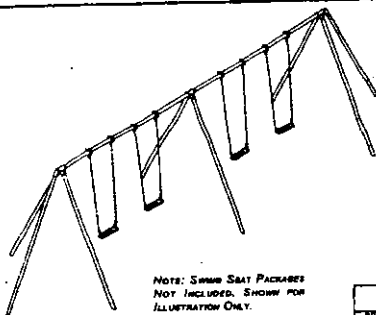

SEE PAGE 7 FOR TOPPIES

NOTE: SWING SEAT PACKAGES
NOT INCLUDED, SHOWN FOR
ILLUSTRATION ONLY.

PART No.	No. Sections	No. Seats	Topset Height
8002/P8002	1	2	8'
8003/P8003	1	7	8'
8004/P8004	2	4	8'
8006/P8006	3	8	8'

SPECIFICATIONS

NOTE: THIS INSTALLATION MANUAL SHOULD BE KEPT IN CUSTOMER'S FILE FOR FUTURE REFERENCE.
NOTE: READ INSTALLATION INSTRUCTIONS THOROUGHLY BEFORE STARTING ASSEMBLY. POUR CONCRETE ONLY AFTER FINAL ASSEMBLY IS COMPLETE. BRACING MATERIAL MAY BE REQUIRED DURING ASSEMBLY.
NOTE: DO NOT OVERTIGHTEN BOLTS. TO OVERTIGHTEN MAY CAUSE BUCKLING OR DISTORTION OF SOME PARTS.
NOTE: DO NOT TIGHTEN ANY NUTS, BOLTS, RODS, ETC. UNTIL THE UNIT IS COMPLETELY ASSEMBLED.
TOPSETS: SHALL BE FABRICATED OF 3-3/8" O.D. (194 mm) GALVANIZED PIPE, 10'-0" (305.04 cm) LONG. CENTER OF TOPSETS SHALL BE 3'-1-3/16" (148.06 cm) ABOVE FINISHED SURFACE.
LEGS: SHALL BE FABRICATED OF 4-7/8" O.D. (125 mm) GALVANIZED PIPE.
FITTINGS: GAME TIME'S HEAVY DUTY FITTINGS ARE FABRICATED FROM CERTIFIED MALLEABLE IRON TO INSURE MAXIMUM STRENGTH AND DURABILITY. ALL FITTINGS ARE HOT DIPPED GALVANIZED OR POWDER COATED.
SEAT, CHAIR & HANGERS: SEE SEAT SPECIFICATION SHEET.

FINISH: GALVANIZED OR POWDER COAT OVER GALVANIZED PIPE.
FASTENERS: ALL NUTS, BOLTS, SCREWS, INSERTS, AND LOCKWASHERS USED IN THE ASSEMBLY OF ALL PLAY EQUIPMENT, SHALL BE STAINLESS STEEL, YELLOW DICHROMATE PLATED STEEL, BLUE-COAT PLATED STEEL, MECHANICALLY GALVANIZED OR POWDER COATED/YELLOW DICHROMATE PLATED STEEL. ALL PRIMARY FASTENERS SHALL BE 300 SERIES STAINLESS STEEL. FASTENERS WITH YELLOW DICHROMATE TREATMENT HAVE AN ELECTRO DEPOSITED, 99.8% PURE ZINC SUBSTRATE APPLIED FROM A SPECIALLY FORMULATED SOLUTION SEALED WITH A YELLOW DICHROMATE TOP COAT DESIGNED TO WORK IN CONJUNCTION WITH THE ZINC PLATING. YELLOW DICHROMATE HAS A 320% LONGER LIFE TO WHITE CORROSION AND 275% LONGER TO RED CORROSION THAN DOES HOT-DIP GALVANIZING.
NOTE: ALL WEIGHTS ARE BASED ON AVERAGE COMPARISONS OF EACH PART.
SPECIFICATIONS: GAME TIME'S HAS A POLICY OF CONTINUOUS IMPROVEMENT AND RESERVES THE RIGHT TO DISCONTINUE OR CHANGE SPECIFICATIONS WITHOUT NOTICE.



Copyright 2002
By GameTime
Revised: 09/20/03

1046 SEAT

NOTE: 1046 BUCKET SEAT

SPECIFICATIONS
• Rights are reserved to discontinue or change specifications without notice.
• Bucket Seats shall be fabricated with .007" thick stainless steel inserts covered by a dark green colored EPDM rubber.
• Fully Enclosed Seats shall be fabricated with .007" thick stainless steel inserts covered by a dark green colored EPDM rubber.
• Seats shall be furnished with factory installed "S" Hooks.
• Convertible Ball Seat - an extra piece of furred rubber at the front and back of seat gives it a cushion bumper.
• Note: Weights are based on average comparisons of each part.

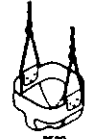
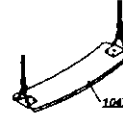

8520 FULLY ENCLOSED SEAT
1464, 1485, 1488, 1489,
1470, 1471, 1472, 1481,
1483, CC1464, CC1485,
CC1468, CC1469, CC1470,
CC1471, CC1472, CC1481,
CC1482, CC1483, CC1484
SEAT PACKAGES



IMPORTANT PRODUCT INFORMATION



SAFETY WARNINGS

- Replace all worn "S" Hooks. "S" Hooks must be completely closed. Failure to close "S" Hooks properly can result in serious injury to the user. Always raise "S" Hooks.
- All equipment should be installed on a soft, resilient, energy-absorbing ground surface.
- **NEVER INSTALL PLAY EQUIPMENT ON CONCRETE OR ASPHALT.** A fall on a hard surface can result in serious injury to the equipment user.
- Always Regularly Inspect/Locate Surfaces (Wear Surfaces) Immediately.
- Work surfaces around equipment should be restored. Concrete footings should never be exposed. Surface depth should comply with installation instructions.
- Equipment should be placed to eliminate conflicting traffic patterns.
- All protruding nuts and bolts should be covered, sharp edges on pipes should be capped or removed. Check for bent, broken or severely worn parts and replace.
- Test overall stability and rigidity of all play equipment. Check for proper assembly, installation and ground anchoring.
- Check for and repair damage caused by wear or vandalism, a major factor in injury-causing situations.
- The **Overweight Safety Stance** as set in the Company's Play set Assembly Agreement.
- Never add components not intended for use with this product.
- Regular maintenance is necessary on this and all playground equipment to ensure the safety of the user.
- Never use playground equipment around or in conjunction with swimming pools, ponds, lakes or any other bodies of water.

ENT 30416:2004 PG 39 of 50 !!!

Exhibit "D"



GAME TIME
c/o Great Western Park & Playground
PO Box 97
2598 West 5700 South
Weleville, UT 84339
Phone: (435)245-5055
Toll Free: (800)435-2735
Facsimile: (435)245-5057
E-mail: info@gwppark.com

GameTime Quotation

Liberty Horns
Attn: Rich Weech
Wild Slide
9075 South 1500 East
Sandy, UT 84093

Ship to Zip: 84093

QTY	ITEM	DESCRIPTION	Est. Weight	Price	Est. Price
2	12023	3 1/2" Uprn Ase-Y Alum F	38		
4	12025	3 1/2" Uprn Ase-Y Alum 10'	88		
4	12027	3 1/2" Uprn Ase-Y Alum 12'	104		
1	12127	60" Clover Climber	106		
1	12202	Chin Bar 2 Piece	12		
1	12506	Modular Double Slide	190		
1	12500	Contoured Seat	43		
1	12726	Wave Climber	94		
1	12814	Dist Steering Wheel-45 1/2" Dia	42		
1	12832	Wildslide Entrance Section	108		
1	12833	Wildslide Exit Section	71		
1	12834	Wildslide Straight Section	87		
1	12835	Wildslide Left Curve Section	27		
1	12836	Wildslide Right Curve Section	27		
1	12839	Wildslide 4" Slide Support	18		
2	18202	Rect Punched Deck P/T	122		
1	18255	4'-0" Transfer Post 45.8" W	250		
1	18256	2'-0" Step Link 36" Deck	155		
Total weight:			1,573		

This quotation is subject to policies in the current GameTime Park and Playground Catalog and the following is based on shipment of all items at one time to a single destination, unless noted. And changes are subject to a \$1,000.00 to be supported by your written purchase order made out to GameTime, c/o Great Western Park & Playground, Inc. factory, firm for 30 days from date of quotation.

Payment terms: Payment in full, net 30 days subject to approval by GameTime Credit Manager. A 1.5% per month finance charge will be imposed on all past due accounts. Rate/hedge not accepted.

Shipment: order shall ship within 30-45 days after GameTime's receipt and acceptance of your purchase order, color selections, approved submittals, and receipt of deposit, if required.

Freight charges: Prepaid and added at time of invoicing.

Taxes: State and local taxes, if applicable, will be added at time of invoicing unless a tax exempt certificate is provided at the time of order entry. Receipt of goods: Customer shall receive, unload and inspect goods upon arrival, noting any discrepancies on the Delivery Receipt prior to written acceptance of the shipment.



GAME TIME
c/o Great Western Park & Playground
PO Box 97
2598 West 5700 South
Weleville, UT 84339
Phone: (435)245-5055
Toll Free: (800)435-2735
Facsimile: (435)245-5057
E-mail: info@gwppark.com

GameTime Quotation

Liberty Horns
Attn: Rich Weech
9075 South 1500 East
Sandy, UT 84093

Ship to Zip: 84093

QTY	ITEM	DESCRIPTION	Est. Weight
1	8002	3-Leg Hd Trnd (Swing/Gov) F, 2 3/4" O/D	219
2	1481	2554 Back Seat 2 3/4" O/d	24
1	1886	# Picnic Table Portable	210
1	P1836	# Coated Bench Pans 24"	96
Total weight:			549

This quotation is subject to policies in the current GameTime Park and Playground Catalog and the following is based on shipment of all items at one time to a single destination, unless noted. And changes are subject to a \$1,000.00 to be supported by your written purchase order made out to GameTime, c/o Great Western Park & Playground, Inc. factory, firm for 30 days from date of quotation.

Payment terms: Payment in full, net 30 days subject to approval by GameTime Credit Manager. A 1.5% per month finance charge will be imposed on all past due accounts. Rate/hedge not accepted.

Shipment: order shall ship within 30-45 days after GameTime's receipt and acceptance of your purchase order, color selections, approved submittals, and receipt of deposit, if required.

Freight charges: Prepaid and added at time of invoicing.

Taxes: State and local taxes, if applicable, will be added at time of invoicing unless a tax exempt certificate is provided at the time of order entry. Receipt of goods: Customer shall receive, unload and inspect goods upon arrival, noting any discrepancies on the Delivery Receipt prior to written acceptance of the shipment.

Exclusions: unless specifically included, this quotation excludes all site work and landscaping, removal of existing equipment, acceptance of equipment and off-loading, storage of goods prior to installation, equipment assembly and installation, safety surfacing, barriers and drainage provisions.

To order: Please complete the acceptance portion of the quotation and provide either to teachers, purchase order copy and other key information requested. Acceptance of the proposal indicates your agreement to the terms and conditions stated herein.

The 974 Exhibit "E"

ENT 30416-2004 06 40 of 50
Elevation A



Pheasant Pointe
Lehi, Utah

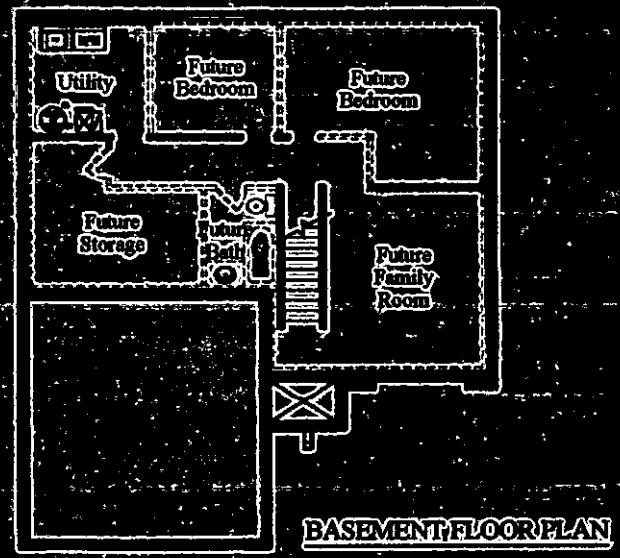
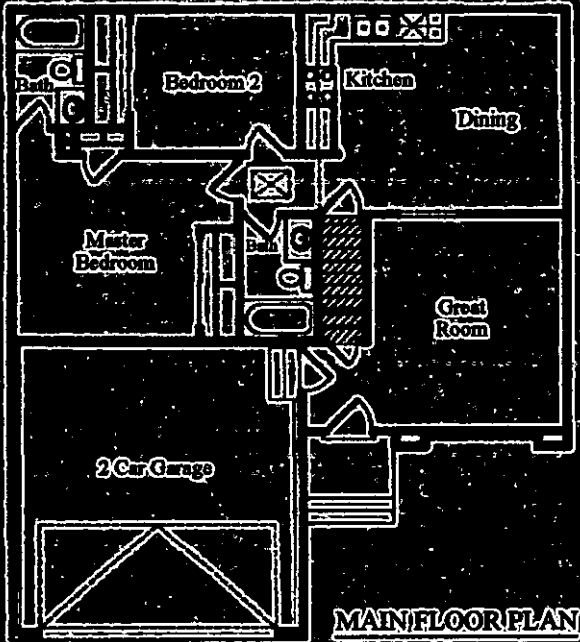

Square Footage
Total - 1,948
Finished - 974
Unfinished Basement - 974

Liberty Homes, Inc. reserves the right to change Plans, Elevations and Specifications without notice. Renderings are an artist's interpretation and may not depict the actual. Room sizes vary slightly from the description shown on the floor plan in view of construction tolerances. 9/03

The 1311

Elevation A



Pheasant Pointe
Lehi, Utah

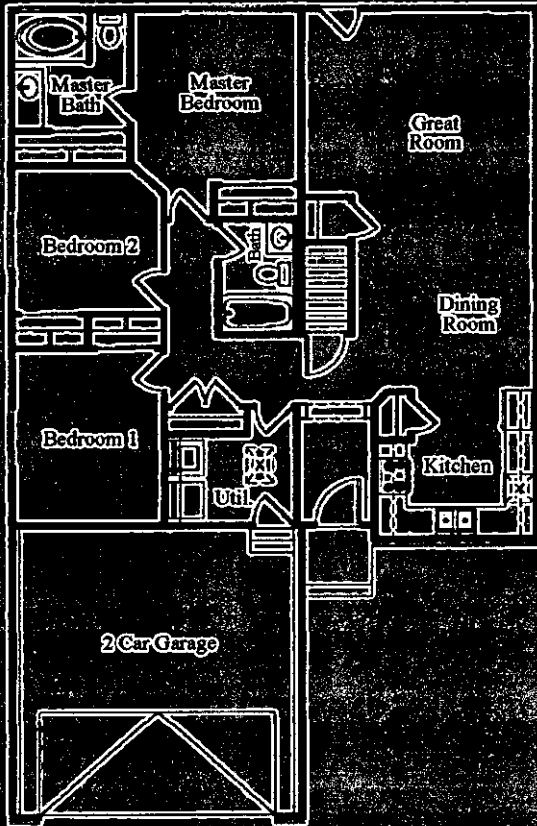

MAIN FLOOR PLAN

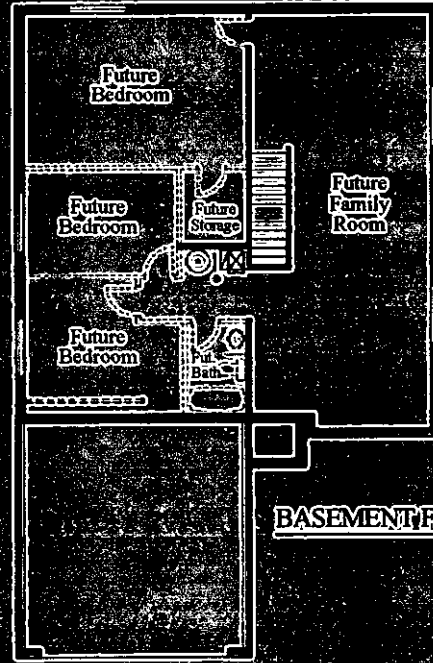

BASEMENT FLOOR PLAN

Square Footage

Total - 2,622

Finished - 1,311

Unfinished Basement - 1,311

The 1348

ENT 30416:2004 Pg 42 of 50



Pheasant Pointe
Lehi, Utah

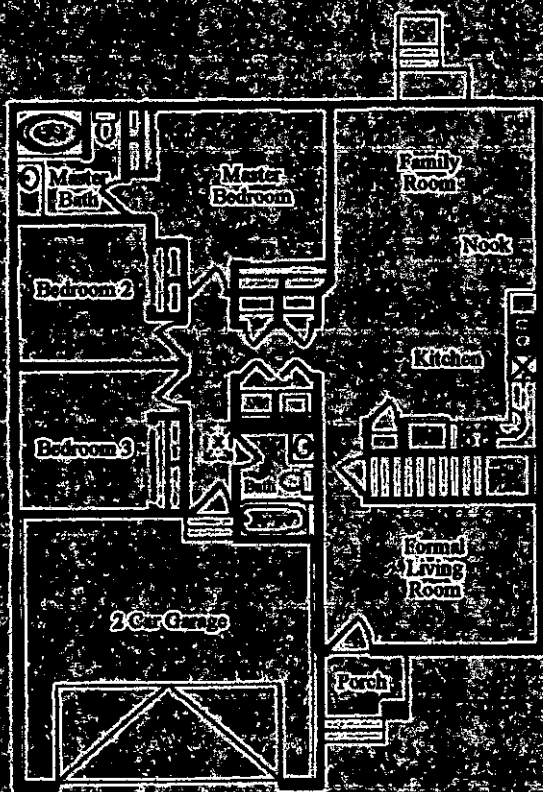

MAIN FLOOR PLAN

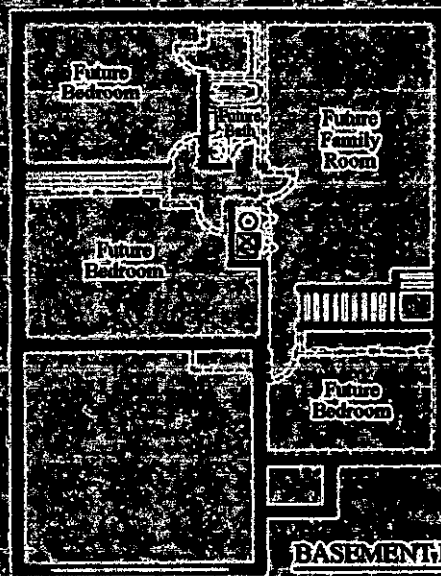

BASEMENT FLOOR PLAN

Square Footage

Total - 2,636

Finished - 1,318

Unfinished Basement - 1,318

The Adamson

ENT 30416:2004 PG 43 of 50

Elevation A



Pheasant Pointe
Lehi, Utah

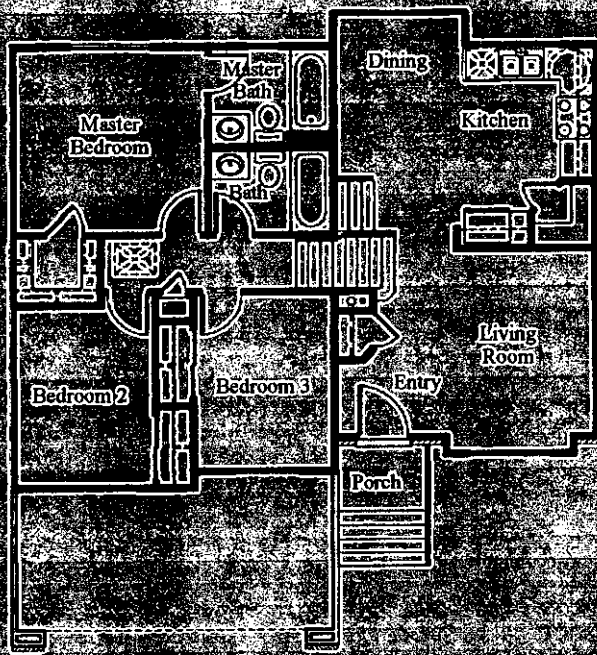

MAIN FLOOR PLAN

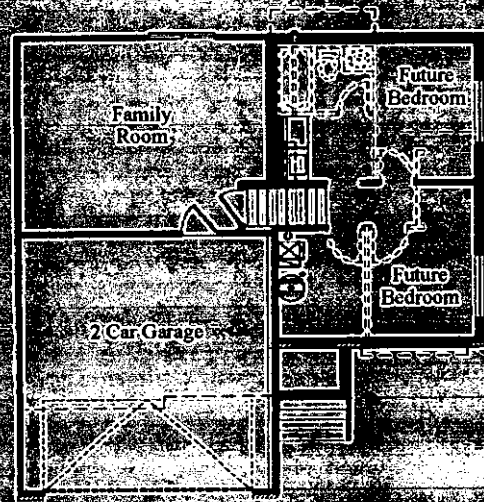

BASEMENT FLOOR PLAN

Square Footage

Total - 1,625

Finished - 1,241

Unfinished Basement - 384

The Concord

ENT 30416:2004 PG 44 of 50

Elevation A



Pheasant Pointe
Lehi, Utah

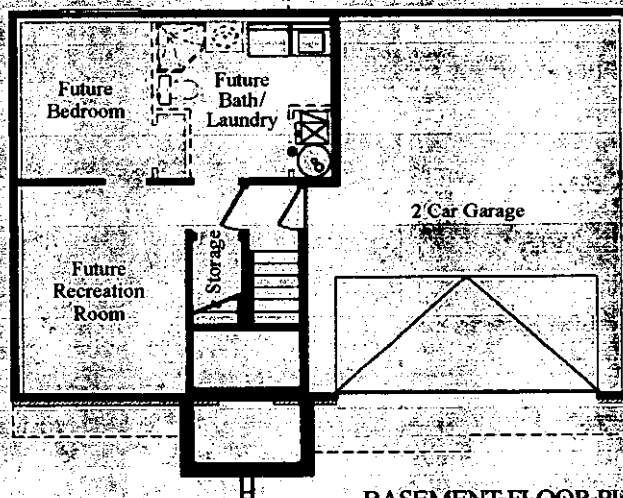
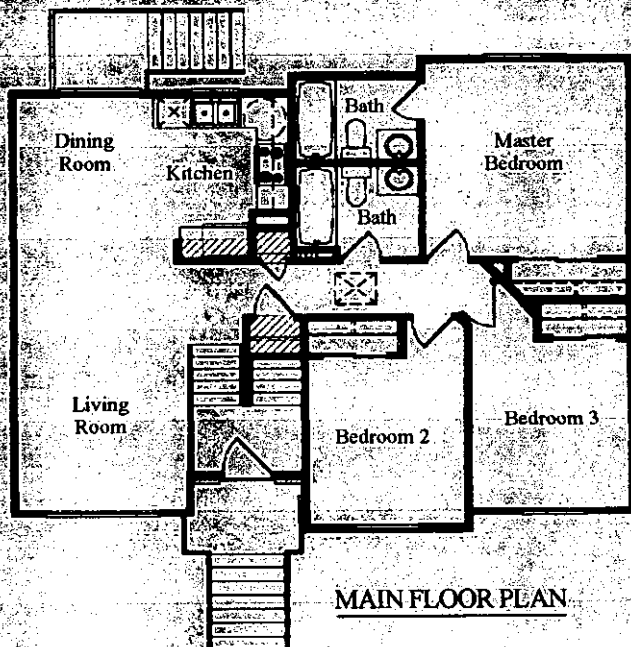

Square Footage

Total - 1,470
Finished - 1,017
Unfinished Basement - 453

The Hamilton

ENT-30416:2004-PG-45-of-50

Elevation A



Pheasant Pointe
Lehi, Utah

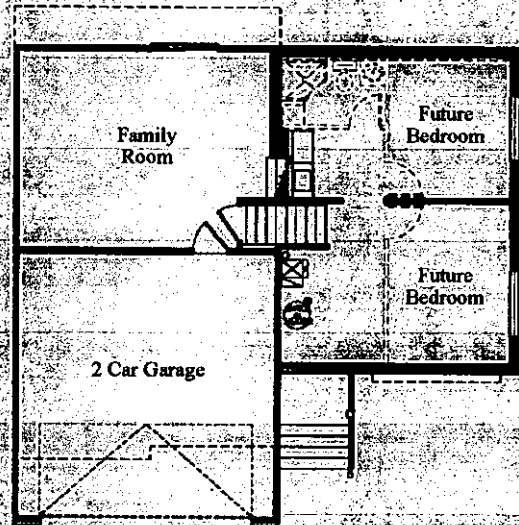
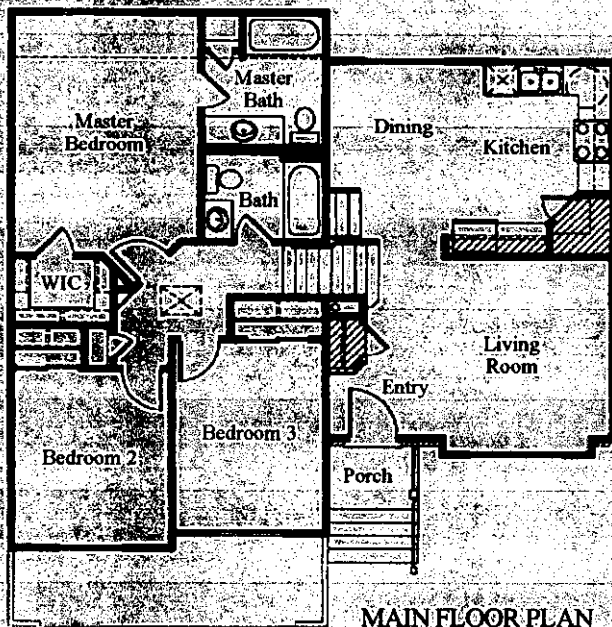

Square Footage

Total - 1,863
Finished - 1,403
Unfinished Basement - 460

Liberty Homes, Inc. reserves the right to change Plans, Elevations and Specifications without notice. Renderings are an artist's interpretation and may not depict the actual. Room sizes vary slightly from the description shown on the floor plan in view of construction tolerances. 9/03

The Independence

ENT 30416:2004 PG. 46 of 50

Elevation C

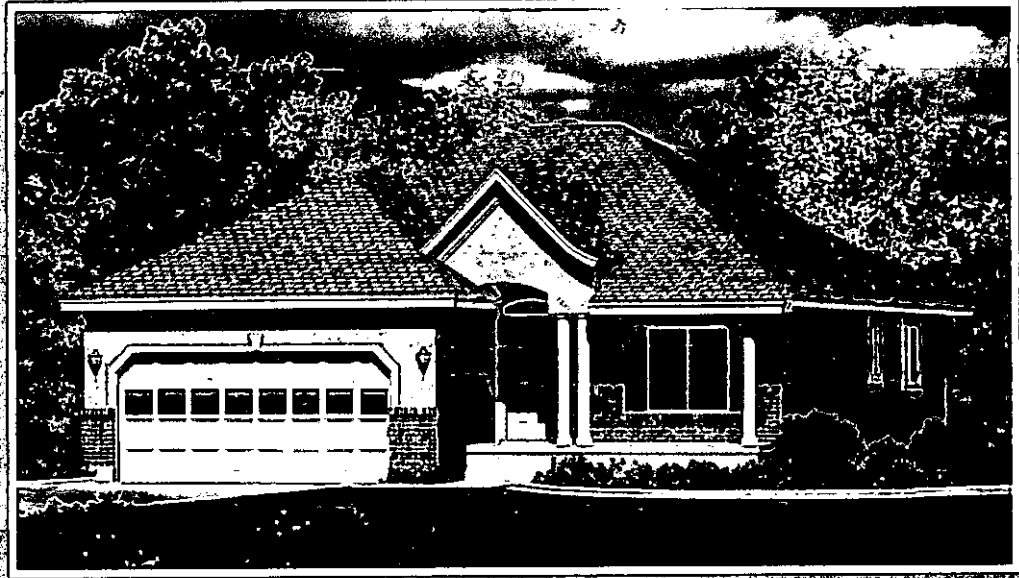

Pheasant Pointe
Lehi, Utah

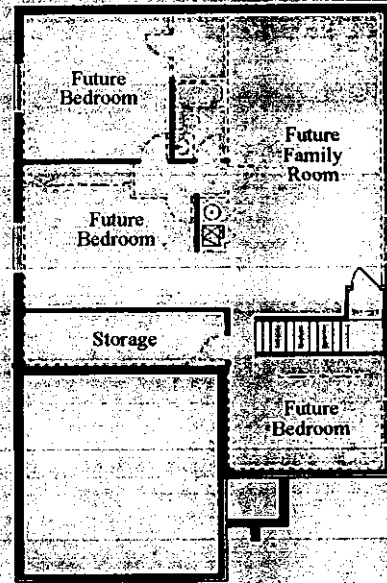
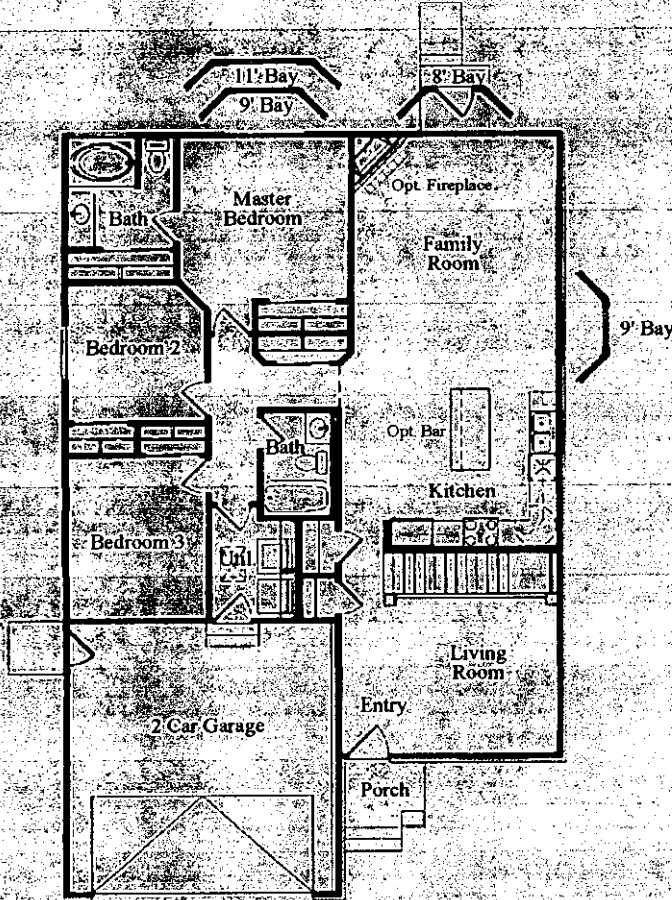

Square Footage

Total = 2,918
 Finished = 1,459
 Unfinished Basement = 1,459

Liberty Homes, Inc. reserves the right to change Plans, Elevations and Specifications without notice. Renderings are an artist's interpretation and may not depict the actual. Room sizes vary slightly from the description shown on the floor plan in view of construction tolerances. 9/03

The Madison

ENT 30416:2004 PG 47 of 50

Elevation A

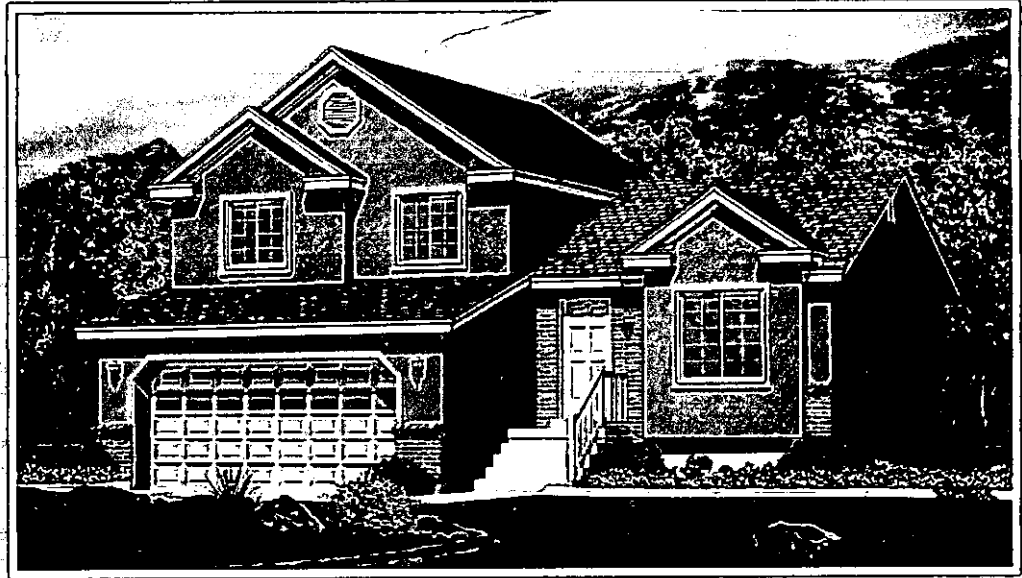

Pheasant Pointe
Lehi, Utah

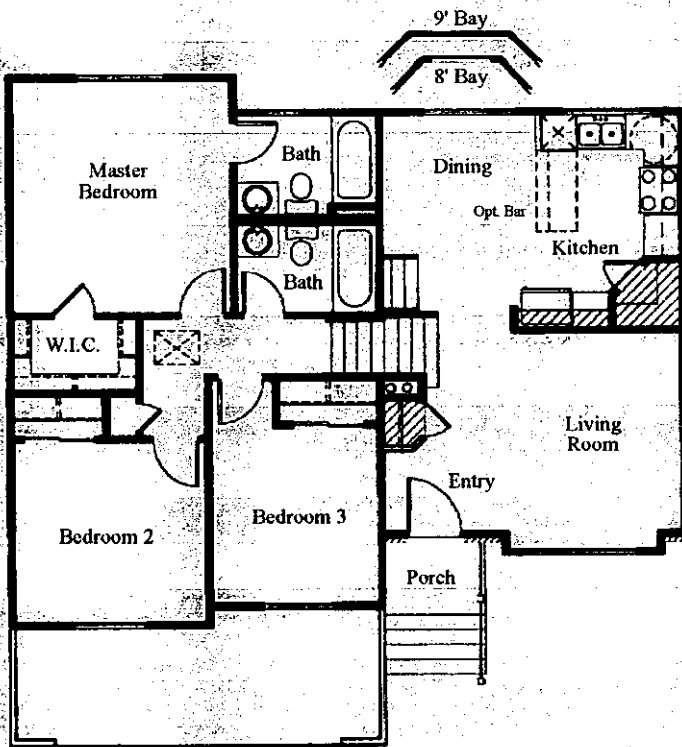

MAIN FLOOR PLAN

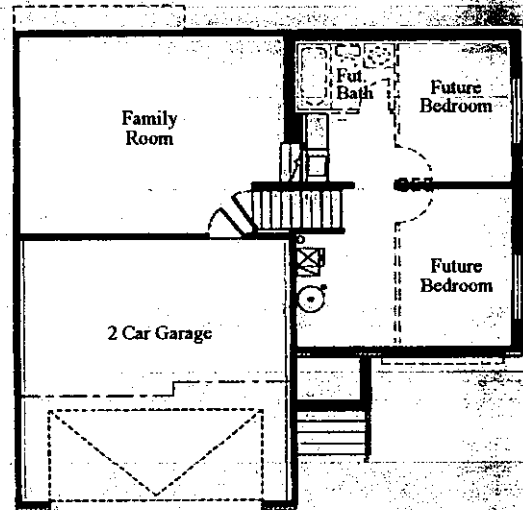

BASEMENT FLOOR PLAN

Square Footage

Total - 1,786

Finished - 1,355

Unfinished Basement - 431

Liberty Homes, Inc. reserves the right to change Plans, Elevations and Specifications without notice. Renderings are an artist's interpretation and may not depict the actual. Room sizes vary slightly from the description shown on the floor plan in view of construction tolerances. 9/03

The Monroe

Elevation A



Pheasant Pointe
Lehi, Utah

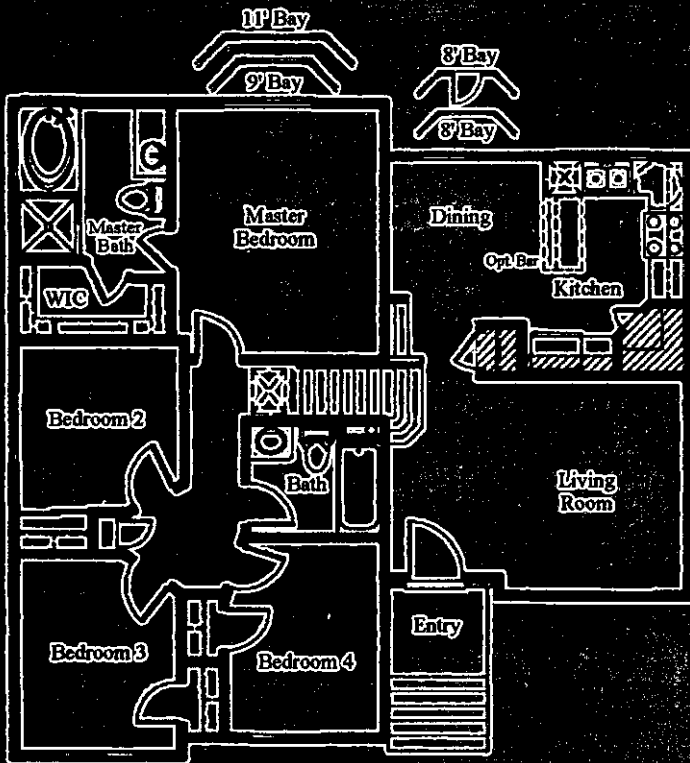

MAIN FLOOR PLAN

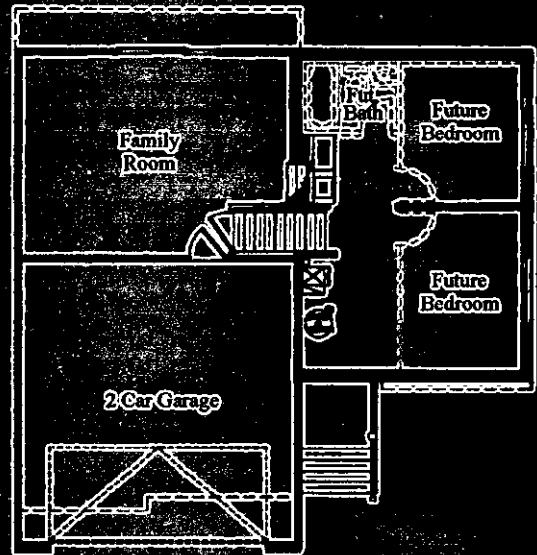

BASEMENT FLOOR PLAN

Square Footage

Total - 1,950

Finished - 1,517

Unfinished Basement - 433

The Rushmore



Pheasant Pointe
Lehi, Utah

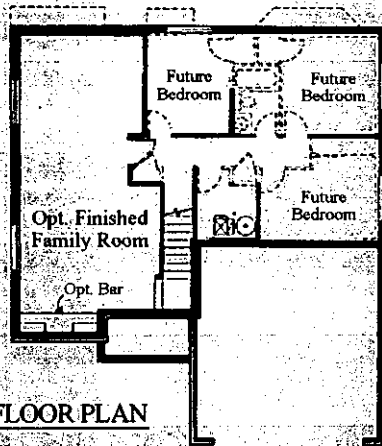
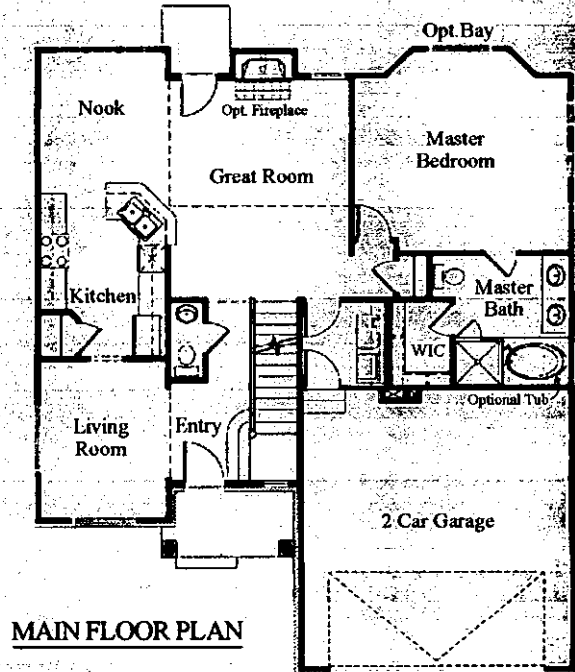
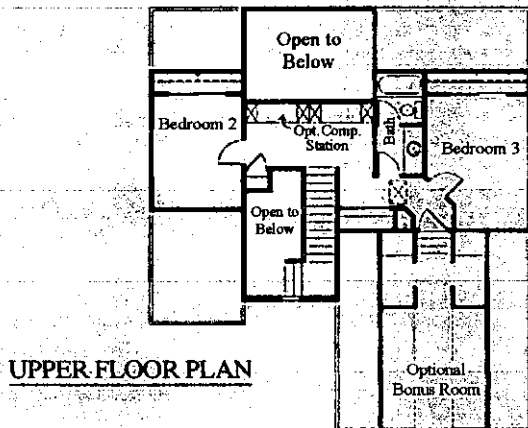

Square Footage
 Total - 3,017
 Finished - 1,668
 Bonus Room - 239
 Unfinished Basement - 1,110

The Sunwood

ENT 30416:2004 PG 50 of 50



Liberty Homes, Inc. reserves the right to change Plans, Elevations and Specifications without notice. Renderings are an artist's interpretation and may not depict the actual. Room sizes vary slightly from the description shown on the floor plan in view of construction tolerances. 9/03